



elektor

electronics & microcontrollers

The Sound of Silence

10 noise cancelling headphones tested

Barometric Altimeter

for mountaineers, delta glider & UL pilots



- ✓ **E-LABS INSIDE:**
PSoC kit with RF module – Portable solar chargers – Noise is not cool!
- ✓ **LED touch panel for Arduino**
- ✓ **Hearing treshold tester**



BitScope

Analog + Digital

Digital Storage Oscilloscope

- ✓ Dual Channel Digital Scope with industry standard probes or POD connected analog inputs. Fully electrically isolated from PC.

Mixed Signal Waveform Analyzer

- ✓ Capture and display analog and logic signals together with sophisticated cross-triggers for precise waveform timing measurement.

Instant Replay Signal Generator

- ✓ Built-in synchronized waveform generator. Synthesize arbitrary waveforms or replay captured analog or logic signals instantly.

Multi-band Spectrum Analyzer

- ✓ Display analog waveforms and their spectra simultaneously in real-time. Baseband or RF signals with variable bandwidth control.

Integrated Waveform Data Recorder

- ✓ Record to disk anything BitScope can capture. Allows off-line replay and waveform analysis. Export captured waveforms and logic signals.

Multi-platform & user programmable

- ✓ Supports Windows, Linux and Mac OSX. USB and Ethernet models with user programming libraries, drivers and customizable software.

Mixed Signal Oscilloscopes



FULL METAL JACKET

BitScope is built tough to last a lifetime.

Enclosed in a new low profile solid extruded aluminium case BitScope 325 can handle the harshest working environments.

Its full metal jacket and electrically isolated design means that unlike cheap plastic alternatives it is also highly noise immune for the most sensitive mixed signal measurement applications.

On the road or in the lab, BitScope is the ideal choice!



Logic/Timing Analyzer Probes



Industry Standard Scope Probes



Software Included

BitScope Software and Libraries

BitScope 325 includes DSO, an intuitive test and measurement software application for your PC.

The integrated test instruments include a digital storage oscilloscope, spectrum analyzer, logic state and mixed signal timing analyzer and an arbitrary waveform generator in one package.

DSO is fast, with display rates up to 50Hz and deep, with capture up to 512kS per frame.

Also included is a built-in data recorder to share captured signals with colleagues or customers via data export and real-time offline analysis.

If you also need programmability, BitScope 325 comes with the BitLib application programming library for custom software applications or full integration with existing third party tools.

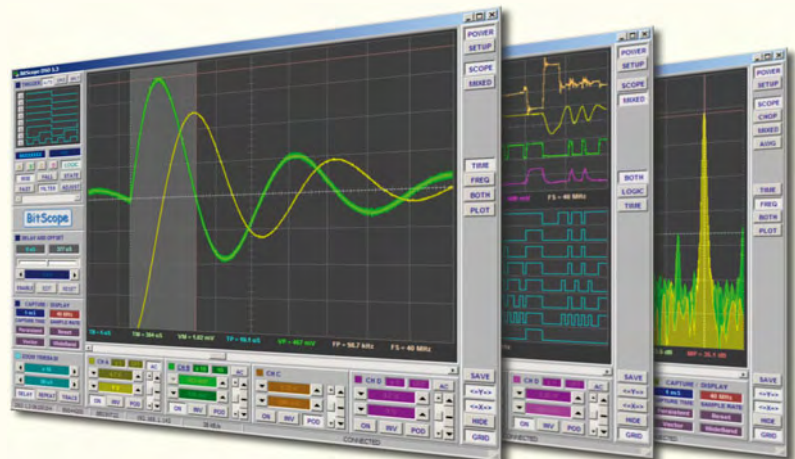

Windows, Linux or Mac
Ethernet or USB

www.bitscope.com

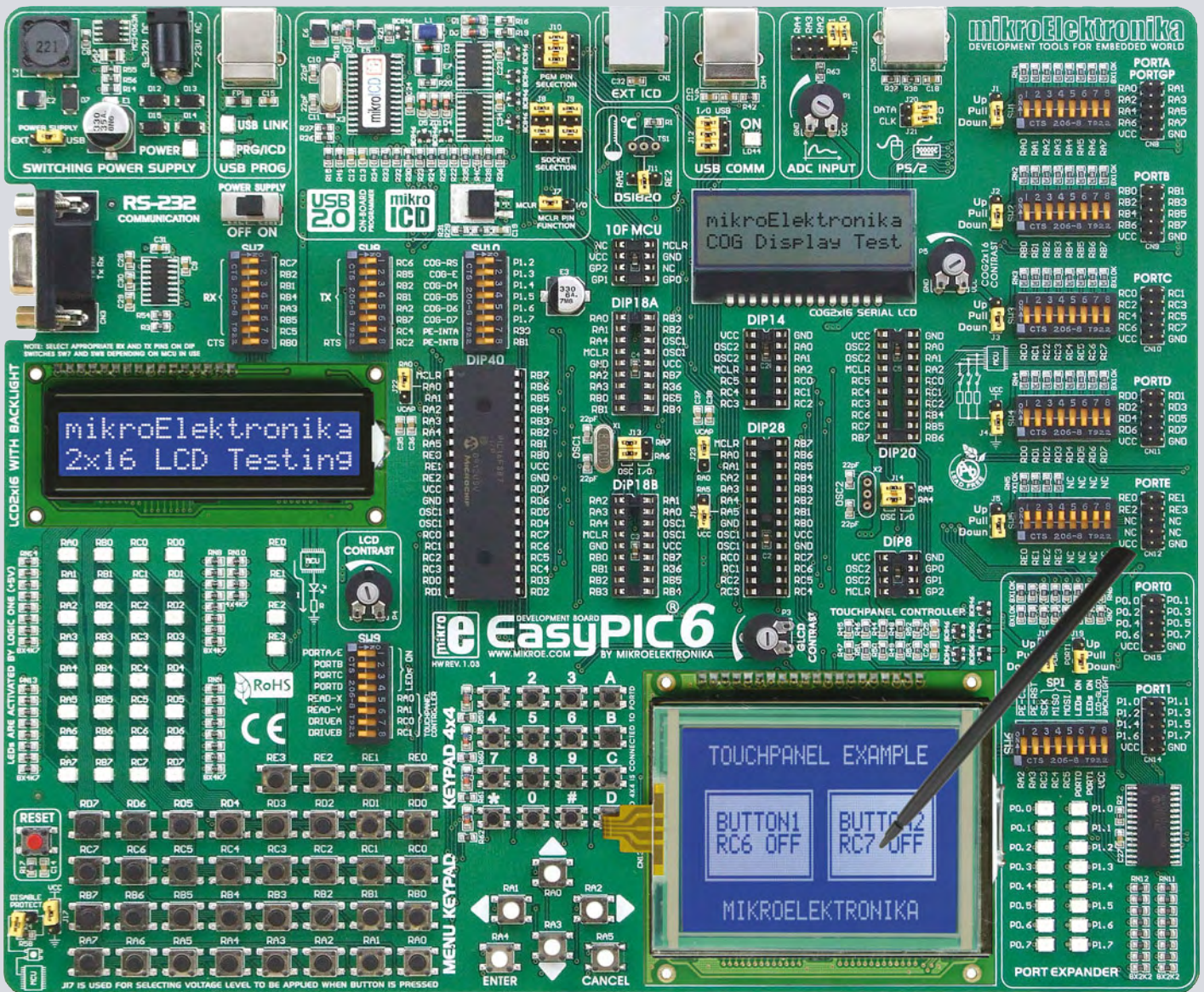

DEVELOPMENT TOOL JUST THE WAY YOU LIKE IT

Everything you've always wanted from a development tool
Experience the ease of creating your own electronic devices!



Thanks to many new features, you can start creating your own devices immediately. **EasyPIC6** supports 8-, 14-, 18-, 20-, 28- and 40- pin PIC microcontrollers. The **mikroICD** (Hardware In-circuit Debugger) enables very efficient step by step debugging. Examples in **C**, **BASIC** and **Pascal** are provided with the board.



Hardware In-Circuit Debugger for step by step debugging at hardware level



High-Performance USB 2.0 On-Board Programmer



Port Expander provides easy I/O expansion (2 additional ports) using serial interface



On-Board 2x16 Serial LCD Display



Full-featured and user-friendly development board for PIC microcontrollers



Keypad enables easy and fast data entry



Find your distributor:
<http://www.mikroe.com/en/distributors/>



mikroElektronika
SOFTWARE AND HARDWARE SOLUTIONS FOR THE EMBEDDED WORLD

Feedback is good!

At social gatherings the conversation often comes round to what you do for a living. Editor sounds a bit exotic and the question then turns to what skills are needed for the job.

Many years ago, a (very) senior editor divulged that you should be something of a craftsman.

The analogy is not a bad one: to be successful you need a little bit of talent, loads of practice and a touch of artistic flair. I have to admit that our magazine is not always a masterpiece but I never doubt the level of commitment of our team. I always look forward to the end of the month when we sit down with some pride (and relief) to thumb through the latest edition hot off the press.

However the analogy breaks down here — unlike the tailor, carpenter or sculptor we never get to see the customer's face when they take ownership — or in our case read the magazine. Rarely do we get to know if our choice of an article was a good one, if the writing style is good or indeed what the overall impression was. It is a shame because we are continually asking questions: How many projects or articles on fundamentals should we run?

Do our soft/hardware descriptions have enough depth? Are readers interested in projects that don't include microcontrollers? Should the articles have a common layout or would it make a more attractive product if each article has a different layout?

Raise that question at an editorial meeting and you are sure of a heated argument. It is interesting to see which work colleague takes which side in the debate. At the end of the day of course what we think is really not important, the customer is king!

We really do value your feedback. Whether you found something to be really interesting or a total turn-off, we don't mind criticism — in fact we encourage it! Maybe you would prefer to see the magazine concentrate on different subject areas or you dislike the direction the magazine is taking. Whatever the case, let us know, we look forward to your views at editor@elektor.com, or by post.

Jan Buiting
Editor

14 Sound Sorcery

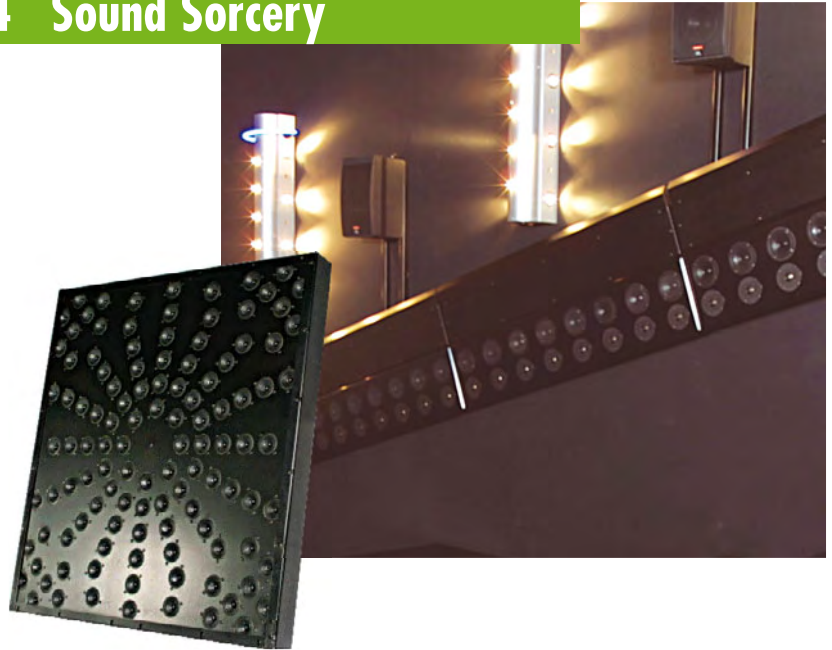

The science of acoustics holds many surprises: sound can be focused into beams, noise can be cancelled out by more noise, and sound waves can be made to appear from nothing as if by magic. This article explains how the tricks are done.

20 Barometric Altimeter

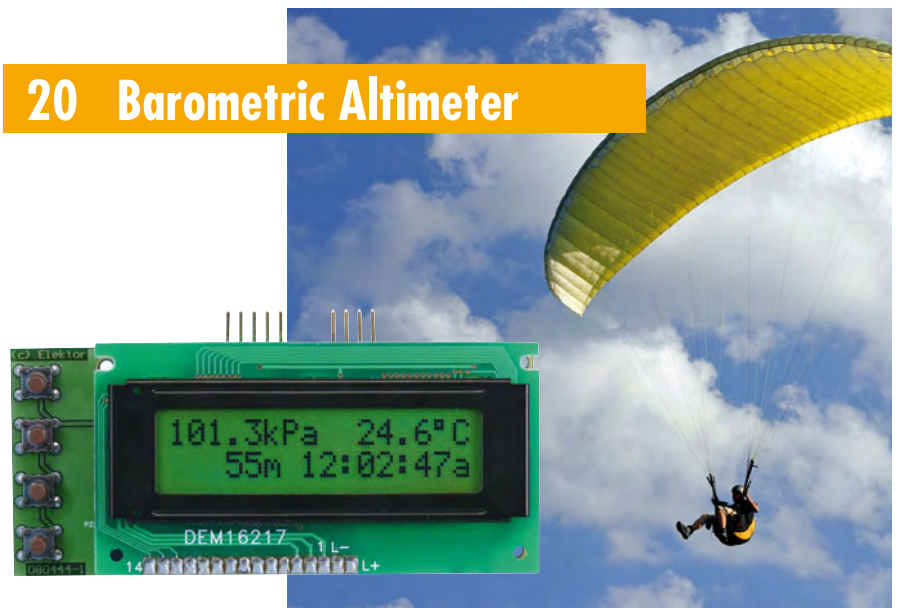

In this project a piezoresistive transducer measures the atmospheric pressure, enabling a PIC microcontroller to use the ISA model (with temperature compensation) to display your current height above sea level (ASL) on an LCD.



48 Hearing Threshold Tester

Very few people realise how much portable music players like iPods and mp3 players can affect our hearing. The hearing threshold tester presented here has been designed to check the state your ears are in.



58 The Sound of Silence

In this article we take a look at a number of noise cancelling headphones, designed to reduce background noise using anti-sound. How do these devices perform, and what's the price tag?

projects

- 20 Barometric Altimeter
- 26 Touch LEDs for Arduino
- 36 Car Tilt Alarm
- 48 Hearing Threshold Tester
- 54 Pocket Preamp
- 58 Getting Started with Embedded C (part 3, final)
- 66 Mini Preamplifier

technology

- 14 Sound Sorcery

new section

E-labs inside

- 43 Portable Solar Chargers
- 44 "Noise is not cool"
- 46 Review: PSoC kit with RF module

info & market

- 6 Colophon
- 8 News & New Products
- 32 High End Audio Amplifier Kits
- 58 The Sound of Silence
- 80 Elektor SHOP
- 84 Coming Attractions

infotainment

- 74 Hexadoku
- 76 Retronics: Philbrick R2-W, the mother of all op amps)

elektor international media

Elektor International Media provides a multimedia and interactive platform for everyone interested in electronics.

From professionals passionate about their work to enthusiasts with professional ambitions.

From beginner to diehard, from student to lecturer. Information, education, inspiration and entertainment.

Analogue and digital; practical and theoretical; software and hardware.



English
German
Dutch
French
Chinese



Italian
Spanish
Swedish
Finnish



Volume 35, Number 393, September 2009

ISSN 1757-0875

Elektor aims at inspiring people to master electronics at any personal level by presenting construction projects and spotting developments in electronics and information technology.

Publishers: Elektor International Media, Regus Brentford, 1000 Great West Road, Brentford TW8 9HH, England. Tel. (+44) 208 261 4509, fax: (+44) 208 261 4447 www.elektor.com

The magazine is available from newsagents, bookshops and electronics retail outlets, or on subscription.

Elektor is published 11 times a year with a double issue for July & August.

Elektor is also published in French, Spanish, American English, German and Dutch. Together with franchised editions the magazine is on circulation in more than 50 countries.

International Editor:
Wisse Hettinga (w.hettinga@elektor.nl)

Editor: Jan Buiting (editor@elektor.com)

International editorial staff: Harry Baggen, Thijs Beckers, Eduardo Corral, Ernst Krempelsauer, Jens Nickel, Clemens Valens.

Design staff: Antoine Authier (Head), Ton Giesberts, Luc Lemmens, Daniel Rodrigues, Jan Visser, Christian Vossen

Editorial secretariat: Hedwig Hennekens (secretariaat@elektor.nl)

Graphic design / DTP: Giel Dols, Mart Schroijen

Managing Director / Publisher: Paul Snakkers

Marketing: Carlo van Nistelrooy

Subscriptions: Elektor International Media, Regus Brentford, 1000 Great West Road, Brentford TW8 9HH, England. Tel. (+44) 208 261 4509, fax: (+44) 208 261 4447
Internet: www.elektor.com/subs

Elektor PCB Service

NEW!

➔ Your professional PCBs and Prototypes

Elektor PCB Service is a new service from Elektor. You can have your designs converted into a professional-quality PCBs via the www.elektorpcbservice.com website. Elektor PCB Service is intended for prototype builders and designers who want to have their PCBs made to professional standards, and for users who want customised versions of Elektor PCBs. If you need a couple of 'protos' with fast turnaround or a batch of 5 to 50 units, we can meet your needs at a favourable price.

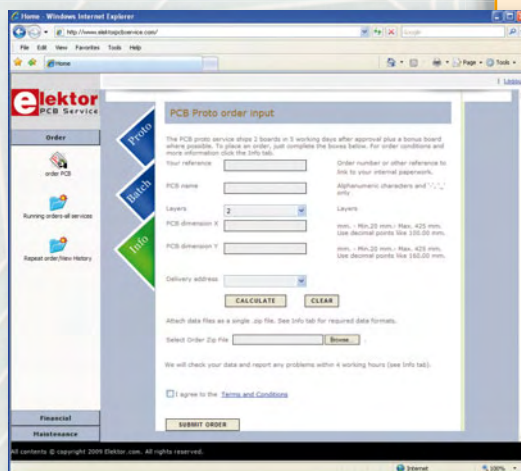

The advantages at a glance

- The PCBs are professional quality.
- No film charges or start-up charges.
- There is no minimum order quantity or charge for this service.
- Available to private and commercial customers.
- We'll first check if your project is producible. We'll let you know within 4 hours!
- In order to supply two PCBs, we make three. If the third board is also good, you receive it as well – free of charge.
- You can use our online payment module to pay easily, quickly and securely with Visa or MasterCard.

Procedure:

1. Create your account
2. Place your order
3. Your project is checked
4. Payment
5. Your order is shipped



Now available for everybody at www.elektorpcbservice.com

Email: subscriptions@elektor.com
Rates and terms are given on the Subscription Order Form.

Head Office: Elektor International Media b.v.
P.O. Box 11 NL-6114-ZG Susteren The Netherlands
Telephone: (+31) 46 4389444, Fax: (+31) 46 4370161

Distribution: Seymour, 2 East Poultry Street, London EC1A, England
Telephone: +44 207 429 4073

UK Advertising: Huson International Media, Cambridge House,
Gogmore Lane, Chertsey, Surrey KT16 9AP, England.
Telephone: +44 1932 564999, Fax: +44 1932 564998

Email: r.elgar@husonmedia.com
Internet: www.husonmedia.com
Advertising rates and terms available on request.

Copyright Notice

The circuits described in this magazine are for domestic use only. All drawings, photographs, printed circuit board layouts, programmed integrated circuits, disks, CD-ROMs, software carriers and article texts published in our books and magazines (other than third-party advertisements) are copyright Elektor International Media b.v. and may not be reproduced or transmitted in any form or by any means, including photocopying, scanning or recording, in whole or in part without prior written permission from the Publisher. Such written permission must also be obtained before any part of this

publication is stored in a retrieval system of any nature. Patent protection may exist in respect of circuits, devices, components etc. described in this magazine. The Publisher does not accept responsibility for failing to identify such patent(s) or other protection. The submission of designs or articles implies permission to the Publisher to alter the text and design, and to use the contents in other Elektor International Media publications and activities. The Publisher cannot guarantee to return any material submitted to them.

Disclaimer
Prices and descriptions of publication-related items subject to change.
Errors and omissions excluded.

© Elektor International Media b.v. 2009

Printed in the Netherlands

Actel offers free reference designs for LCD applications

Actel Corp. is offering five reference designs, free of charge, which are implemented using the Igloo Video Demo Kit. The Igloo Video Demo Kit was jointly developed by Actel, Attodyne, and Avnet Memec. It is available from Avnet Memec and can be ordered online or from any sales office. The available reference designs target the following applications: DVI input to LCD, upscaling, photo viewer, still and video cameras, and video MUXing.

The IGLOO Video Demo Kit consists of two boards: a video demo board and an LCD adapter board. The IGLOO video demo board is

fitted with low-power Igloo FPGA with Flash Freeze technology and features low static power with quick entry to and exit from Flash



Freeze mode. Designers have a choice of several LCD adapter boards with LCD panels of different sizes and resolutions. Two plug-and-play display adapter board are available, and they can be fitted with different LCDs, ranging from 5.5"

to 7" and resolutions from QVGA (320x240) to SVGA (800x480). You can also build your own customized LCD adapter board. The IGLOO video demo board has an IGLOO device that interfaces with several video/image sources, such as a digital visual interface (DVI) input and a CMOS sensor interface. In addition, off-chip memory is provided for data buffer and storage.

www.actel.com/products/solutions/display/refdesign.aspx

(090569-IX)

A new name and new-generation products revitalize embedded software

A change of name signals the dynamic, fresh approach Crosshairs Embedded is bringing to revitalizing embedded software. The company offers customers invaluable insight through precise software solutions, with a new generation of products that deliver on that promise. The change of name from Active DSP to Crosshairs Embedded reflects the company's focus on optimizing embedded systems for international markets. Leading Crosshair's next generation product lineup is the new Functional Debugger Version 1.1. By enabling businesses to debug, monitor and optimize their operat-

ing systems in real time while they're running, it reduces downtime, helps increase efficiency, and leads to greater profits. Businesses will quickly find that Functional

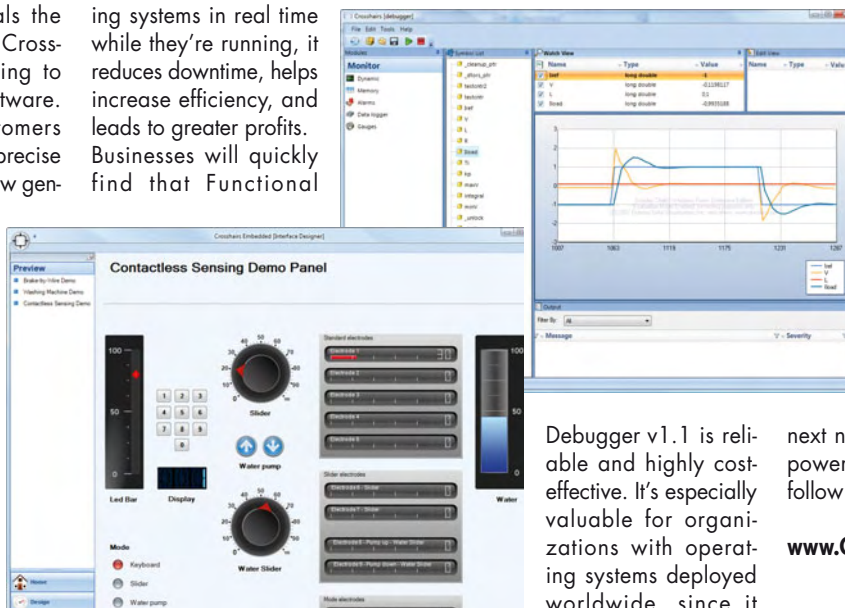

Debugger v1.1 is reliable and highly cost-effective. It's especially valuable for organizations with operating systems deployed worldwide, since it

allows seamless, remote non-intrusive testing and monitoring of embedded systems even at large distances. It's also easy to use and more dependable and adaptable than home-brew software testing solutions.

Functional Debugger v1.1 was officially launched at the Embedded Systems Conference (ESC) 2009 in Boston. The company's

next new-generation product, the powerful Interface Designer, will follow shortly.

www.CrosshairsEmbedded.com

(090569-XIII)

Paper-thin battery ETA scheduled for 2010

As researchers rush to develop commercial versions of printable batteries with structured organic semiconductors on paper-thin, flexible substrates, a German team claims to be on track for a 2010 product launch. Scientists at the Fraunhofer Research Institution for Electronic Nano Systems collaborated on this project with colleagues at Chemnitz University of Technology and Menippus GmbH (Chemnitz, Germany). They are

targeting applications such as smart credit cards with battery-powered displays that can display the card balance and other account information.

Fraunhofer's batteries use zinc anodes and manganese cathodes, which react with each another to produce electricity. These materials are gradually used up over the

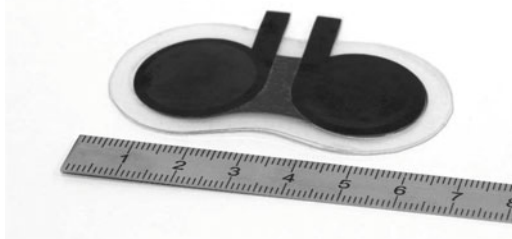

lifetime of the battery, making them suitable for short-term applications like greeting cards with built-

in music players. The researchers are aiming at a price point under 10 cents per card.

The batteries are produced using a screen printing technique in which a squeegee presses the organic semiconductor materials through a screen onto a flexible substrate. In a process resembling lithography, templates are used to

create successive layers of battery components, each about the thickness of a human hair, until enough bulk has been achieved for a particular application. Printable batteries for smart cards would weigh less than 1 gram

and be less than 1 mm thick. The organic materials generate 1.5 V per cell, like conventional batteries, and they are free of hazardous substances such as heavy metals used in conventional rechargeable and alkaline batteries.

Fraunhofer researchers said their battery is already working in the lab, and their industrial partners estimate that the first commercial models will be ready for beta testing later this year.

www.fraunhofer.de/en/press/research-news/2009/july/printable-batteries.jsp

(090569-X)

KEF creates unique flagship speakers

In loudspeaker engineering as in everything else, true innovation sometimes requires rethinking a problem from first principles. So when KEF set out to create the Concept Blade, a unique not-for-sale speaker system designed to showcase their speaker technology, the acoustic research department had complete freedom to explore radical new options, with no preconceptions or aesthetic restrictions, and no reliance on existing components. After three years of exhaustive test-

ing and analysis of traditional as well as experimental approaches to loudspeaker design, they perfected a combination of technologies that generates an extraordinarily pure sound. Concept Blade is forged from these technologies. Its exceptional acoustic integrity derives from the fact that every element of the system has been conceived to perform as a single coherent unit with all parts working in flawless harmony. The highest quality components and advanced materials have been

used in perfecting the design. While the technologies incorporated into the design are often very complex, the focus has always been on simplicity. The drivers are specifically designed to behave with zero break-up or resonance over their frequency range, and the distinctive cabinet is carefully engineered not to interfere with the purity of their output.

www2.kef.com/us/conceptblade

(090569-IV)



DC source-measure instruments compatible with ACS basic edition software

Keithley Instruments, Inc. has enhanced its popular ACS Basic Edition software, adding support for a broader line of source-measure (SMU) instrumentation. With the introduction of Version 1.1, ACS Basic Edition, a member of Keithley's Automated Characterization Suite (ACS) family, can now support a far broader range of DC voltage and current test capabilities. It's compatible with the company's full SMU offering, the broadest array of choices in the industry. Depending on the SMU selected, ACS Basic Edition supports sourcing and measuring up to 5A or 1100V DC on indi-



vidual channels. The newly expanded source and measure ranges are especially useful for tests on evolving photovoltaic panels/solar cells and high power electronics in research, failure analysis, and inspection applications. ACS Basic Edition now also supports combining different SMU models into

a single test, allowing easier configuration, test creation, and test execution – with no need to write code. The software now supports combining hardware from any of Keithley's SMU families into a single test, including Series 2600 and 2600A System SourceMeter instruments, Series 2400 SourceMeter instruments, the Model 4200-SCS Semiconductor Characterization System, and the Model 237 High-Voltage SMU.

www.keithley.com/products/semiconductor/?mn=ACSBasicEdition

(090711-IX)

Orchid's new 48V 1,400 watts brushless DC motor controller

The new low cost brushless DC motor controller board from Orchid Technologies Engineering and Consulting, Inc, packs enormous power into a tiny electronics package. Designed to drive 48-Volt brushless DC motors up to 1400 watts, this miniature controller may be the smallest in its class. Small physical sizes make it pos-

sible to develop high torque and operating speeds when overall product size and weight are application limited. The new board combines cost-sensitive engineering with precision power electronics to craft an efficient, high-performing, three-phase power-output stage. Orchid selected an ST7MC microcontroller

as the brains of this brushless DC motor controller. The ST7MC's feature-rich complement of flash program store, static RAM, Eeprom, patented motor controller, timers, analog-to-digital conversion circuitry, and robust processor reliability controls make the ST7MC a perfect fit in the motor control marketplace.

The ST7MC's patented motor control subsystem provides a highly cost-effective method to control many different types of brushless DC motors. Sensor and sensorless motors, 120- and 60-degree styles are all supported.

www.orchid-tech.com

(090712-I)

True-Touch the HD Brilliance on hot new Samsung I8910 phone

Samsung Electronics Company Ltd. has selected the TrueTouch™ solution from Cypress to implement the touchscreen in the new I8910 mobile phone. The I8910, also known as the OMNIAHD, lets users 'Touch the HD Brilliance' of the world's first phone with 720P high-definition video recording and super vivid 3.7" AMOLED display. Samsung selected the TrueTouch

solution based on its fast response time, gesture support and character recognition capabilities that enable the I8910's outstanding multimedia player and fast internet browsing. In addition to the TrueTouch touchscreen, the I8910 employs a Cypress MoBL® dual-port as an interconnect between the application and baseband processors, increasing multimedia and comput-

ing performance and lowering system power in the new phone. According to Samsung, Cypress's TrueTouch and MoBL dual-port solutions gave the company the ability to go beyond the competition with new features and functions that customers are excited to use.

www.cypress.com/go/TrueTouch

(090568-XI)



Antero Standard Development Kit for ARM7

The Antero Single Board Computer (SBC) family is the newest series of products from Vesta Technology. The Antero Development Kit is optimized for embedded control applications and allows the SBC to be very configurable, making it the Swiss Army knife of SBC's. Based on the 32 bit ARM7 technology, the SBC offers high performance with low power consumption, and small form factor. Antero features a rich I/O set that includes CAN bus, USB, I²C, SPI, multiple Serial, PWM, Quadrature and digital. Antero is constructed in the Indus-



try Pack form factor. The IP module version is compatible with Industry Pack carrier boards. The Antero SBC with its full development environment is being offered now at a special introductory rate. The SBC comes with software tools, sample application programs and RTOS. Antero is ideal for machine and industrial control, equipment monitoring, process control, instrumentation and many other applications.

www.vestatech.com

(090568-XII)

New microchip technology performs 1,000 chemical reactions at once

UCLA researchers have developed technology to perform more than a thousand chemical reactions at once on a stamp-size, PC-controlled microchip, which could accelerate the identification of potential drug candidates for treating diseases like cancer. Their study appeared in the Aug. 21, 2009 edition of the journal *Lab on a Chip* and is currently available online.

A team of UCLA chemists, biologists and engineers collaborated on the technology, which is based on microfluidics — the utilization of miniaturized devices to automatically handle and channel tiny amounts of liquids and chemicals invisible to the eye. The chemical reactions were performed using in situ click chemistry, a technique often used to identify potential drug molecules that bind tightly



to protein enzymes to either activate or inhibit an effect in a cell, and were analyzed using mass

spectrometry. While traditionally only a few chemical reactions could be pro-

duced on a chip, the research team pioneered a way to instigate multiple reactions, thus offering a new method to quickly screen which drug molecules may work most effectively with a targeted protein enzyme. In this study, scientists produced a chip capable of conducting 1,024 reactions simultaneously, which, in a test system, ably identified potent inhibitors to the enzyme bovine carbonic anhydrase. A thousand cycles of complex processes all took place on the microchip device and were completed in just a few hours. At the moment, the UCLA team is restricted to analyzing the reaction results off-line, but in future, they intend to automate this aspect of the work as well.

(090711-1)

Surface soldering the Propeller chip

Parallax Inc., has partnered with SchmartBoard to create an easy Propeller prototyping system in the form of a kit.

If you are new to surface soldering and don't know where to start, the P8X32A-Q44 SchmartBoard kit is a perfect starting point. The SchmartBoard technology makes surface mount soldering easy. Once completed, the board will host Parallax's most powerful

microcontroller on this convenient development platform, allowing access to all 32 I/O pins of the multicore Propeller chip. The kit retails at \$39.99 and includes surface-mount and through-hole package types for some components, offering a soldering choice and challenge.

www.Parallax.com
(search "SchmartBoard or "27150")

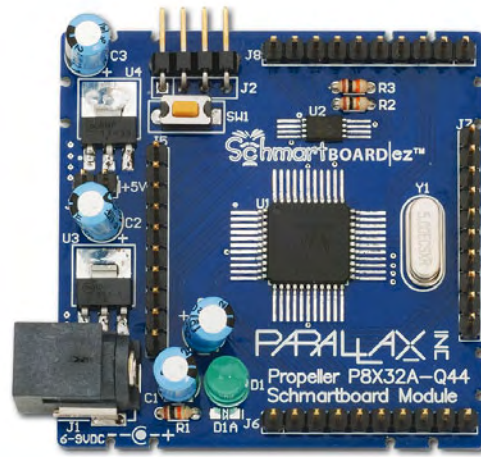

(090711-II)

SchmartBoard: cheapest ever development board for Microchip 8-bit PICs in SOIC case

Eight-bit PIC® microcontrollers in 8-, 14-, 18-, 20- and 28-pin SOIC packages are all supported by the new PIC Development Board SchmartModule. A user simply hand solders a PIC® chip using SchmartBoard's 'EZ' solder technology, adds a row of headers (included), and then configures jumpers for the PIC type which was soldered onto the board. The 2" x 2.5" board has an onboard 5 V power regulator and reset button. It also supports optional external clock options, ICSP and RJ11 interfaces for programming.

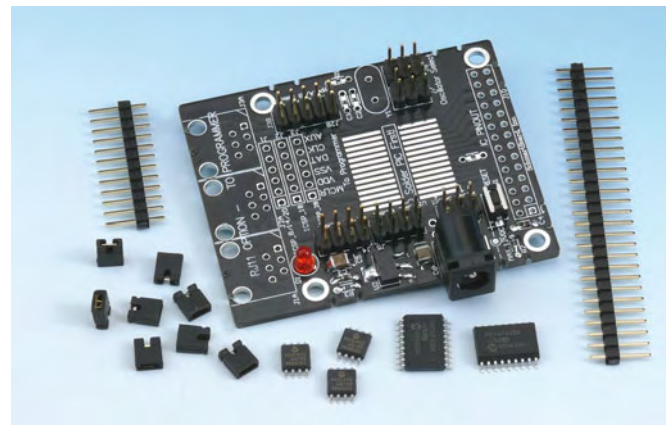

The new PIC development board is claimed to be the most flexible option on the market for PIC chip

compatibility. If you use 8-bit PICs often, at \$15, this inexpensive solution offers the opportunity to

keep a number of development boards on hand and knowing they will work with any SOIC 8-bit PIC chip they use in the future. Also, a distributor can now stock board to support over 100 PICs as opposed to a variety of different boards to support the many 8-bit PIC options.

SchmartBoard will follow this product up with an 8-bit PIC board for chips in a QFP form factor, boards for 16-bit PICs and some development boards for other microcontroller manufacturers.

www.schmartboard.com

(090711-V)

Rapid prototyping of digital AV applications and ARM Cortex-M3 embedded systems

Toshiba Electronics Europe (TEE) and Keil have announced a development kit that simplifies the design of digital AV applications and other embedded systems based on Toshiba's microcontrollers based on the ARM Cortex™-M3 processor. The new MCBTMPM330 Starter Kit provides all of the hardware and software necessary for the rapid evaluation, prototyping and testing of applications based on the Toshiba TMPM330Fx range of devices.

The new Starter Kit comprises the MCBTMPM330 Evaluation Board, a Keil™ ULINK-ME USB-JTAG adapter, an evaluation version of Keil's Microcontroller Development Kit (MDK-ARM), and a variety of example programs. All power for the evaluation board is provided by the host PC via the ULINK-ME.

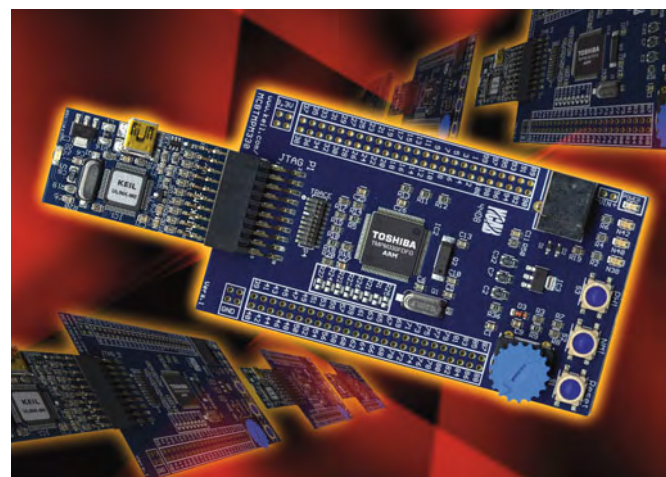

As well as the microcontroller, the evaluation board incorporates an adjustable analogue voltage source for testing the TMPM330Fx integrated ADC, JTAG and ETM con-

nectors for enabling developers to debug and gather trace information from their applications. The board's MCU pinout area provides easy access to the device's peripherals.

The MDK-ARM tools provide developers with industry-standard compilation tools and sophisticated debugging support. It features the Keil µVision Integrated Development Environment (IDE), debugger and simulator, the ARM Compilation tools, and an RTX real-time kernel. Detailed startup code for the Toshiba microcontrollers, Flash programming algorithms for ULINK and extensive program examples all ensure that users can quickly begin developing their applications.

The MCBTMPM330 Starter Kit is available now and is the first in a line of collaborative products from Toshiba and Keil.

www.toshiba-components.com
www.arm.com

(090711-IV)

Pololu Jrk USB motor controller with feedback

Pololu announces the release of the jrk line of USB motor controllers: highly configurable, versatile devices that make it easy to add open- or closed-loop control of brushed DC motors to your computer- or microcontroller-based project. The jrk supports four interface modes — USB for PC-based control, logic-level (TTL) serial for use with embedded systems, analog voltage for simple potentiometers and joysticks, and RC pulse for radio control systems — and can perform open-loop speed control, closed-loop position control with analog voltage feedback to make

your own servos, and closed-loop speed control with frequency feedback from a tachometer. The jrk 21v3, the smaller of the two units currently available, has an operating range of 5-28 V and can deliver 3 A continuous output (5 A peak). The jrk 12v12, the more powerful of the two, has an operating range of 6-16 V and can deliver a continuous output of 12 A (30 A peak). Both devices can handle transients of up to 40 V.

A free configuration program (Windows XP and Vista compatible) is available for calibrating your system. Real-time plots of variables

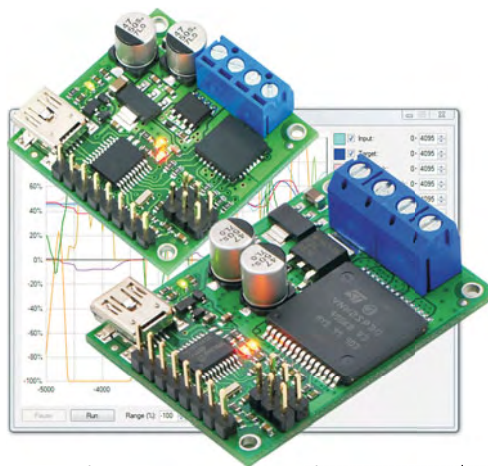

such as control input, feedback, motor output, and current draw make it easy to fine-tune settings such as PID constants, acceleration, and current limit for your application.

The unit price is \$49.95 for the jrk 21v3 (item #1392) and \$99.95 for the jrk 12v12 (item #1393). All prices plus P&P.

www.pololu.com

(090711-VIII)

Sparkfun's Holy Grail of new products

Sparkfun's lively and fun approach to DIY electronics is once again demonstrated by a flurry of new products released on the market, a few of which are listed here —



there's much more to marvel at on their website.

Trackballer is a breakout board for the Blackberry Trackball. The board comes equipped with four

hall-effect sensors, LEDs (RGBW), and the Blackberry Trackball. Check out the video!

O-Clock, the AVR Oscilloscope Clock is back in a new all SMD version. It turns your X-Y analogue oscilloscope into 1 of 30 display combinations.

Solar cell is Sparkfun's largest yet! It's rated for 8 V open voltage and 650 mA short circuit.

The TFT-LCD ScreenKey is a tactile switch combined with a 128x128 TFT-LCD display that can generate any text or graphics with up to 65,536 colour support. Why use just a button when you can display full colour images on one?

New Arduino Shields include the Arduino Mega (ATMega1280), which now has its own prototyping shield and the WingShield Screw-

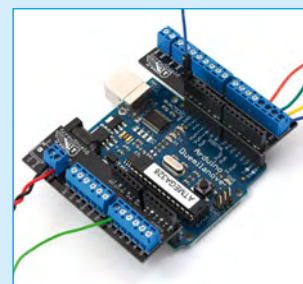
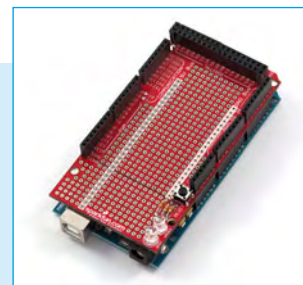

Shield which extends all pins of the Arduino out to 3.5 mm pitch screw terminals. Both sides of the shield are broken out to the side of the Arduino, to allow access to

everything on the main Arduino board.

www.sparkfun.com

(090711-VI)

better electronics from nanoelectronic transistors and a biological machine

Lawrence Livermore National Laboratory (LLNL) researchers have devised a versatile hybrid platform that uses lipid-coated nanowires to build prototype bionanoelectronic devices. Mingling biological components in electronic circuits could enhance biosensing and diagnostic tools, advance neural prosthetics such as cochlear implants, and could even increase the efficiency of future computers.

While modern communication devices rely on electric fields and currents to carry the flow of infor-

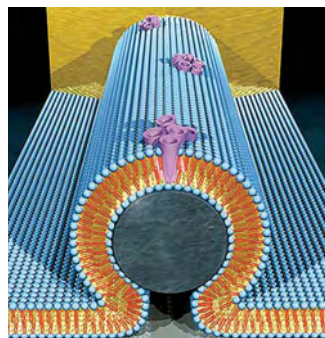

mation, biological systems are much more complex. They use an

arsenal of membrane receptors, channels and pumps to control signal transduction that is unmatched by even the most powerful computers. For example, conversion of sound waves into nerve impulses is a very complicated process, yet the human ear has no trouble performing it.

To create the bionanoelectronic platform the LLNL team turned to lipid membranes, which are ubiquitous in biological cells. These membranes form a stable, self-healing, and virtually impenetrable barrier

to ions and small molecules.

The researchers incorporated lipid bilayer membranes into silicon nanowire transistors by covering the nanowire with a continuous lipid bilayer shell that forms a barrier between the nanowire surface and solution species.

The team showed that by changing the gate voltage of the device, they can open and close the membrane pore electronically.

<https://www.llnl.gov/>

(090711-III)

125nA Supervisory circuits extend battery life

Maxim Integrated Products introduces the MAX16056-MAX16059, ultra-low-power microprocessor supervisory circuits that monitor a single system supply voltage. These devices consume an industry-low 125 nA supply current to extend battery life in power-sensitive applications.

Additionally, the devices feature capacitor-adjustable watchdog (MAX16056/MAX16058) and reset timeouts to maximize design flexibility. This configurability makes it easy for designers to quickly change design parameters, and enables the supervisors to be used in unique power-saving schemes.

To minimize system power consumption in battery-powered applications, the MAX16056-MAX16059 can be used to periodically wake up the processor to complete its required duties, and then turn off the processor when those functions are complete. At a

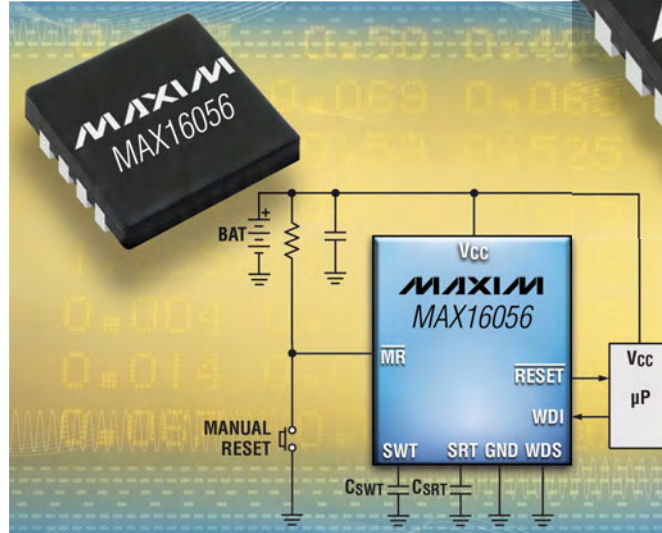

mere 125 nA, the operating supply current of these supervisory circuits is much lower than the standby supply current of a typical microcontroller (> 1 microamp). The MAX16056-MAX16059 can monitor voltages from 1.575 V

to 4.625 V. These devices assert a reset signal whenever the Vcc supply voltage drops below the reset threshold, manual reset is pulled low, or the watchdog timer (MAX16056/MAX16058) runs out. The reset function fea-

tures immunity to power-supply transients.

<http://www.maxim-ic.com/MAX16056>

(090711-VII)

Advertisement

ANTEX

Antex offer a wide choice of input voltages and bit profiles for our soldering iron range

visit: www.antex.co.uk

60+ years of experience

www.antex.co.uk

It may surprise you but buying an Antex soldering iron costs less than you think in the long run. British made to exacting standards, they last significantly longer than many imported brands. With a wide range of thermally balanced models, and temperature controlled irons too, you can always be sure to find an iron that meets your needs.

A large range of replacement tips are available for most irons, and technical help is on hand from our offices in Devon UK.

Buy Online

Our new website has all of our irons, and soldering spares and accessories available 24hrs a day. Most items are shipped next day.

Why not give antex.co.uk a try!

Antex Electronics Ltd
2 Westbridge Industrial Estate
Tavistock, Devon PL19 8DE, UK
Tel: +44(0)1822 613565
Fax: +44(0)1822 617598
Email: sales@antex.co.uk
Web: www.antex.co.uk

Sound Sorcery

Sound projection, noise cancellation and wave field synthesis

By Jens Nickel (Elektor Germany Editorial)

Music, speech, noisy neighbours – sound is all around us. And yet the science of acoustics holds many surprises: sound can be focused into beams, noise can be cancelled out by more noise, and sound waves can be made to appear from nothing as if by magic. Here we explain how the tricks are done.

The human sensory system has evolved over hundreds of thousands of years of hunting and gathering. From the rustle of a predator to the music of a flute, sounds are continuously bombarding us from all sides, and humans have acquired the essential survival skill of determining the direction from which a sound comes.

So it seems like magic that it is possible to create a focused beam of sound: music or speech made clearly audible if you stand at just the right point, but take a step to the left or right and the sound disappears. Focused beams of sound can be used, for example, to link visual advertising with an audio track that can only be heard by a person standing directly in front of the relevant hoarding or display. Museums, art installations and other exhibitions are all already making use of 'directed sound'.

So how does it work? Even an ordinary loudspeaker is somewhat directional, but the beam is generally not narrow enough for the applications mentioned above. This is because the wavelength of sound waves in the audible range is large compared to the size of the transducer, which therefore behaves approximately as a point source. If we want to focus the sound into a narrower beam, it is necessary to make the transducer several metres across.

We will look at three of the simpler techniques for making a focused beam of sound. The easiest to understand is the reflector method. Here the transducer is mounted backwards, pointing towards a spherical reflector. The sound waves emitted hit the reflector and are sent back in the desired direction (**Figure 1**). This creates a kind of focus where sound waves arrive with equal delays: this means that relative phase is preserved. We therefore have constructive interference (see the text box for more about interference). This method has not seen wide use, apart from in the 'Sound Dome' system by the American company Brown Innovations [1].

Phase, delays and transducer arrays

A similar effect can be achieved by using a large number of individual transducers, all fed with the same signal and arranged in a spherical pattern (Figure 1). It is also possible to use a flat array of loudspeakers, as long as we ensure that each loudspeaker is fed with a suitably-delayed signal. The nearer a loudspeaker is to the middle of the array, the greater the delay required in the signal that is fed to it relative to the signal fed to the loudspeakers at the edge

Figure 1.
Reflector (left) and spherical loudspeaker array (centre): there is constructive interference at the focus. The same effect can be achieved with a planar array if the transducers are driven with suitably phase-shifted signals.

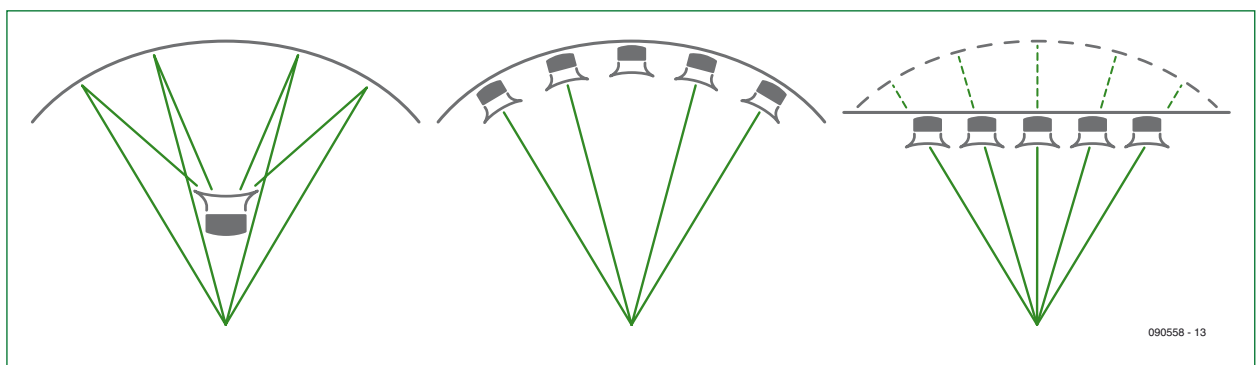

090558 - 13

of the array. Usually a DSP device is used to generate the required signals, with an independent D/A converter and amplifier for each output transducer. An advantage of this digital beamforming technique, in contrast to the reflector-based techniques, is that both the direction and the width of the beam can be adjusted without making mechanical alterations to the system. The American company Dakota Audio [2] makes loudspeaker arrays based on this technique, for use in advertising, exhibitions and other applications.

The technique also has an interesting application in consumer electronics. The Japanese company Yamaha makes so-called digital sound projectors aimed at the home cinema and surround sound market (Figure 3). Forty small tweeters create several beams of sound in various directions; the lower frequency components are handled by conventional mid-range and bass loudspeakers. An optional sub-woofer is also available [3]. The loudspeakers simultaneously generate a separate sound beam for each channel (front left and right, centre, rear left and right). The front and rear channels are emitted at preset angles to the left and right, to be reflected from the walls of the room (see Figure 4). The rear channels then appear to be coming from behind the listener. The designers seem to have been very successful in their work: both the specialist press and customers have raved about the intensity of the surround effect, although it cannot match a carefully-set-up high-end traditional surround sound system consisting of five separate loudspeakers. The sound projector system is aimed at customers with limited space or whose aesthetic sensibilities rule out installing a full surround-sound system. The YSP-1100 model, which has a 40-speaker array, can be bought on-line for a little over £/€ 500. There are cheaper models with smaller arrays, as well as rather dearer models with various extra features.

Not to be outdone, Pioneer introduced its digital sound projector PDSP-1 [4], a rather more complex device sporting an astonishing 254 transducers and 254 digital amplifiers (Figure 5). The device came on the market in 2003 for around £15000, but is no longer available. Jürgen Timm of Pioneer Germany says the “very expensive project” was discontinued when British start-up ‘1 Limited’, on whose development work the sound projector was based, fell prey to “internal disputes”.

Ultrasound as a carrier

A third technique for generating a beam of sound uses ultrasonics. Since ultrasound can have a wavelength of just a few millimetres, it is relatively easy to construct one sufficiently large transducer (or a dense array of smaller transducers) which, rather than behaving as a point source, creates a plane wave (see text box). In order to generate frequencies in the audible range a technique called intermodulation is used, where two powerful ultrasonic waves of different frequencies are overlaid. The ultrasonic waves affect the properties of the air through which they travel in such a way that non-linear effects cause them to combine to produce a wave at a new frequency. Many readers will be familiar with the way that mixture products are generated when two radio frequency signals are combined in a non-linear circuit, and indeed the mathematics behind the two effects is the same [5]. If we simultaneously generate an ultrasound signal at 40 kHz and another at 41 kHz, an audible sound at the difference frequency of 1 kHz will be produced; and in general it is possible to modulate the ultrasound signals to create audible speech and music. The audible sound is not actually present at the source

of the ultrasound: it is only created along the length of the emitted beam. The situation can be visualised as a string of ‘virtual loudspeakers’. Since the ultrasound signals and the audible signal propagate with the same speed, there is strong constructive interference along the axis of the beam, and destructive interference at various angles off the axis

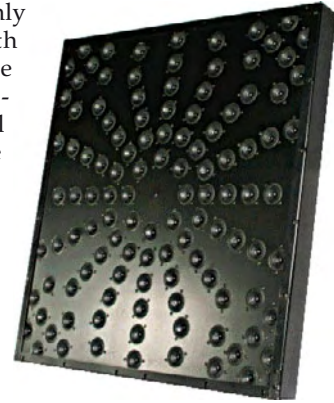

Figure 2. This loudspeaker array by Dakota Audio is designed for ceiling mounting. The circumference is about 90 cm.



Figure 3. The Yamaha ‘Sound Projector’ uses 40 tiny tweeters to create a surround sound effect without the need for additional speakers behind the listener.

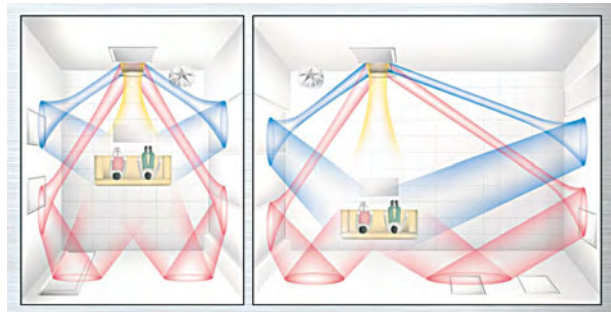

Figure 4. In sound projection systems a separate beam is produced for each channel (front left and right, centre, and rear left and right). The beams are simultaneously generated by the transducer array. (Graphic courtesy Pioneer)



Figure 5. The Pioneer PDSP-1 digital sound projector sports 254 transducers (and 254 digital amplifiers), but unfortunately is no longer available.



Figure 6. The Sennheiser 'AudioBeam' uses 150 piezoelectric transducers to generate a directional ultrasound field onto which the audio information is modulated.



Figure 7. The 'HSS' system, made by American company ATC. One panel, including electronics, costs around US\$ 1400.



Figure 8. Hairdresser high-tech. In the ceiling there are panels that form part of the 'Audio Spotlight' system by American manufacturer Holosonics. The panels create an ultrasound field using a vibrating metal-polymer hybrid film.



Figure 9. The LRAD (Long Range Acoustic Device) is the circular object towards the top right of the picture. The loudspeaker arrangement creates sound at levels of up to 150 dB, enough even to ward off pirates!

of the beam. This kind of system can produce a beam that carries over a distance of more than ten metres, with an attenuation of 20 dB in signal level at an angle of 5° off-axis. Commercial products based on this principle, such as those made by Sennheiser [6] and the American companies Holotronics [7] and American Technology Corporation (ATC) [8], consist of an ultrasound driver unit and an amplifier with the necessary modulation electronics (see Figure 6 and Figure 7). Using these devices it is possible to 'speak' to a chosen person in a crowd. Figure 8 shows another interesting possibility.

Although the focusing effect is astonishingly sharp, the method does suffer from a disadvantage: it is only practical to generate frequencies above about 300 Hz. In contrast to this, phased array techniques are limited only by the capability of the individual transducers used, easily reaching 70 Hz or even lower.

Manufacturers are of course keen to point out the limitations of their competitors' approaches. Phased array enthusiasts Dakota Audio characterise the reproduction of natural sounds using ultrasonic systems as screechy or like breaking glass. Meanwhile, Dr Joseph Pompei, founder of Holosonics, stresses that driver area is the only thing that matters when trying to produce a focused beam of sound. He claims that it can be proved mathematically that any additional phasing or masking can only have an adverse effect on beam quality.

As well as the HSS ultrasound system ATC also makes the LRAD (long range acoustic device), shown in Figure 9. This loudspeaker system is capable of transmitting acoustic messages or warning sounds over long distances, including over open sea. The most powerful model can even be used by a ship's crew to ward off pirates: according to ATC the sound pressure level can reach 152 dB, with levels of up to 90 dB at a distance of 300 m. Various US military organisations have already ordered LRAD devices, and so technical details are kept largely under wraps. Wikipedia claims that the system uses an array of tweeters driven in phase, giving a moderately narrow beam [9]. Wikipedia also has an entry on current research into so-called 'sonic weapons' [10], though of course publicly-available information is again rather thin on the ground.

Anti-sound

Now we turn to another counter-intuitive aspect of acoustics. The effects of long-term exposure to noise from machinery or vehicles can range from discomfort to serious health problems. It is possible to reduce the noise level using passive damping, but an active technique is also available: anti-sound, or active noise cancellation. The technique uses the principle of destructive interference (see text box). It is easy to see that sound and anti-sound of the same frequency must have opposite phases, and the theory of this was worked out in the 1930s; the practice, however, has fallen somewhat behind and active noise cancellation is only really successful in certain special situations.

If the source of unwanted noise acts (at least approximately) as a point emitter, and remains fixed in position, then things are relatively straightforward. A microphone is placed between the noise source and the area where the noise is to be cancelled, arranged so as to pick up the sound. Some simple electronics shifts the phase of the signal and outputs the result to a loudspeaker, which creates the wanted anti-sound.

A suitable circuit can be built fairly easily using analogue components [11]. Alternatively it is possible to digitise the

noise signal, and use a DSP device to calculate the (digital) anti-sound signal, which is then converted back to analogue form and amplified. There are also dedicated devices available [12] which additionally offer various filtering functions. As sound travels at about 340 m/s in air, it is necessary to calculate the anti-sound signal quickly: a delay of 1 ms corresponds to a distance of 34 cm.

The method described above is known as the 'feedforward' technique, where the system attempts to cancel the sound before it reaches the target area. An alternative is the 'feedback' technique, which works well in noise-cancelling headphones. Here a microphone is placed within each ear-cup of the headphones to measure the noise signal, and an algorithm is used to calculate the anti-sound signal that should be added in to minimise the overall error from the wanted signal. Headphones like this (Figure 10) are aimed not only at the consumer audio market but also at aircraft pilots and call centre workers. The environment in which the system has to work is relatively friendly, in that the area over which cancellation must take place is very small, much smaller than the wavelength of the frequency components that are to be cancelled. This means that the sound pressure level is roughly constant over the whole of the inside of the headphone ear-cup. It is therefore perhaps more appropriate to think of the system as regulating the pressure inside the ear-cup to the desired value at any given instant rather than as creating an anti-sound. The principle is particularly effective at lower frequencies, for example when cancelling the engine noise from a turbine helicopter.

If we combine these active techniques with passive measures that in practice work better at higher frequencies,



Figure 10. Anti-sound headphones by Sennheiser. The 'NoiseGuard' range uses analogue circuitry, which the manufacturer claims has benefits in terms of cost and speed.

noise-cancelling headphones can achieve an attenuation of 20 dB over the entire audio spectrum. There is a test of various headphones with active noise cancellation elsewhere in this issue.

The road to peace

For the reasons we mentioned the techniques above are particularly effective at combating noise from engines, fans and other machinery. The technical difficulties increase considerably, however, if it is desired to suppress noise that is complex in nature over a wide area, especially if the sources of the noise are not stationary. Analysing the entire sound field in terms of the amplitude and direction of the noise sources requires a spherical array of closely-

Effects

Interference

Sound propagates through a medium, such as air, as a wave. The sound wave from a point source can be visualised as similar to the waves on the surface of the water when a stone is thrown into a lake, although in the case of the sound wave the motion of the particles involved in the wave is parallel to the direction of propagation rather than perpendicular to it. When a trough in a sound wave from one source meets a peak in the wave from another source, the waves cancel each other out: this phenomenon is called destructive interference. If two peaks meet one another, the result is constructive interference.

Plane waves

A so-called 'plane wave' is produced when several sources, all emitting the same sound signal, are arranged in a plane array. For clarity we show a one-dimensional arrangement here. A similar situation occurs when the diameter of the transducer is much larger than the wavelength of the sound.

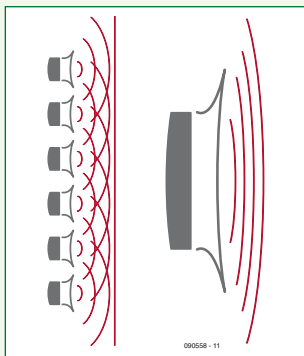

Virtual sound sources

If the sources are arranged to emit signals with different phases, it is possible to create curved wavefronts. If the transducers are driven with the right signals it is possible to create a

wavefront shape that matches exactly that which would be produced by a single loudspeaker acting as a point source. With a densely-packed spherical arrangement of loudspeakers it is possible to simulate the effect of sound sources at any point outside (or even inside) the

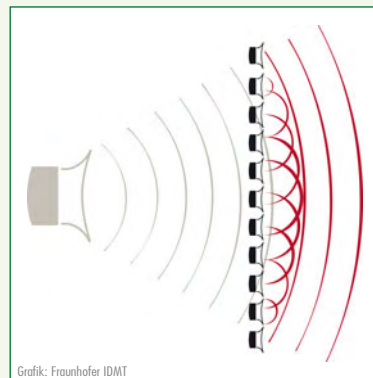

sphere. Using a circular array of loudspeakers it is possible to simulate closely the effect of a loudspeaker anywhere within the plane of the circle. The distance between adjacent transducers in the circle should be less than half the wavelength of the highest frequency component to be generated.

Sound field analysis

The position of a sound source can be determined from the signals picked up by microphones arranged in a grid. A complete sphere of microphones is needed in order to identify sources located anywhere in the surrounding space. The signals picked up determine the sound field at all points within the sphere.

If all the sound sources to a good approximation lie in a single plane, a circular microphone array is sufficient.

Figure 11.
The electronics in the Wuppertal anti-sound system. The converter card has 24 analogue inputs and twelve analogue outputs. (Photograph courtesy WaveScape Technologies GmbH).

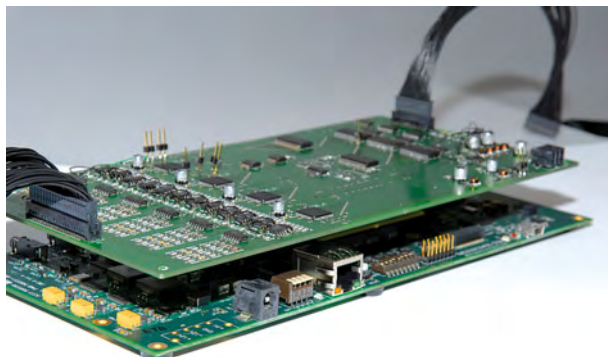

packed microphones around the target area (see the text box on sound field analysis).

Professor Detlef Krahe and his team at the Faculty of Electrical Engineering of the University of Wuppertal in Germany [13] has taken up this challenge. The long-term aim of the research is to create an affordable, weatherproof system that can cancel street noise over the area of a balcony or patio. Since the vast majority of the relevant noise sources lie in a horizontal plane, the engineers can represent them using a two-dimensional model. A circular array of microphones is used, placed roughly at ear height around the area where the noise is to be cancelled. As Krahe explains, a microphone is needed every 35 cm (approx. 1 foot) in order to analyse frequencies up to 500 Hz adequately: this figure is derived using a spatial analogue of the Nyquist sampling theorem. In practice two microphones are used at each point so that both the sound pressure and its gradient can be measured.

Within the ring of microphones is a ring of loudspeakers that creates an anti-sound field matching the noise sound field. The computation involved is 'simply' to calculate a suitable transfer function for each combination of one microphone and one loudspeaker. The calculation must be done within the 2 ms that it takes for an incoming sound wave to propagate from the microphone ring to the loudspeaker ring. According to Professor Krahe, with an array of 24 microphones and 12 loudspeakers the job is now within the capabilities of a single DSP device: an older version of his system required a network of four Texas Instruments TMS320C6713 processors, but the most recent version runs on a single TMS320C6455. This latter device, clocked at 1 GHz, is capable of performing eight billion multiply-accumulate operations per second. To minimise the propagation delay through the electronics, special low-latency A/D and D/A converters are used. The A/D converter selected is a successive approximation type, the ADS8364 from Texas Instruments, with a conversion time of 4 μ s. D/A conversion is done by a Burr-Brown DAC7744, which has a conversion time of just 10 μ s. **Figure 11** shows

the main circuit board of the system with a daughter card carrying the converters for 24 analogue input channels and 12 analogue output channels.

The system was demonstrated working in prototype form at the CeBit exhibition in 2002, but now, some years later, the system is still undergoing extensive adjustments and fine tuning. The demands on the system are enormous. The anti-sound signal must be matched to the incoming noise signal to within 1 dB of amplitude and to within 6° in phase over the entire frequency range to achieve a noise attenuation of 20 dB [14].

It's a beautiful noise

At the Fraunhofer Institute for Digital Media Technology (IDMT) in Ilmenau, Germany, the concerns are rather different. Their aim is to reconstruct recorded sound sources as faithfully as possible using wave field synthesis (WFS) [15]. The German engineers have taken the theory, which was developed in the 1980s at the Technical University of Delft in the Netherlands, and converted it into a market-ready product [16]. A WFS system can be used to play back ordinary audio material, such as a stereo or surround-sound signal. A circular formation comprising a large number of loudspeakers, all driven from a computer, can generate 'virtual loudspeakers' at any desired position outside the physical array. Each source channel can be assigned to a different virtual loudspeaker. Whereas a conventional system consisting of five or seven physical loudspeakers set around a living room always involves a compromise to the quality of the sound stage, sound played through a WFS system has a very sharply defined aural image. Also the so-called 'sweet spot' (the listening area where the effect is most striking) is considerably enlarged, which increases the range of possible applications: for example, the 'Linden Lichtspiele' cinema in Ilmenau has been fitted with a WFS system by Fraunhofer IDMT (see **Figure 12**). The auditorium is surrounded by loudspeakers, arranged in panels each comprising eight mid-range devices and eight tweeters. Each panel also contains the amplification circuitry, and receives audio information over an ADAT lightpipe.

As you might imagine, the computer power required to generate all these audio signals is considerable. According to Dr Sandra Brix, an engineer at Fraunhofer IDMT, a modern PC (with four quad-core processors) is enough for a smaller system with twelve groups of eight channels. She adds that besides the audio rendering functions, the computer also performs filtering and delay interpolation functions for rapidly-moving sources. The system can also add room reflection and reverberation effects, for example to simulate a concert hall.

Conventional multi-track audio material does not really challenge the WFS system. The system is most impressive

Figure 12.
A wave field synthesis system in the 'Linden Lichtspiele' cinema in Ilmenau. The system has over 192 separate channels. (Photograph courtesy Fraunhofer IDMT/Ingo Herzog).



when the position of an audio source is known along with the signal it is producing. The MPEG-4 compression standard supports 'audio objects', and the system can process up to 64 of these objects simultaneously in real time. Each can be independently positioned anywhere inside or outside the area covered by the system. The positions can even be changed dynamically during a performance. The audio objects might be the individual instruments of an orchestra or extra sounds added into a mix by a DJ during a live performance. Assuming the style (and volume) of the music doesn't put you off, you can experience the effect for yourself at the famous 'Tresor' club in Berlin, which is equipped with a WFS system made by Iosono GmbH [17], a spin-off company from Fraunhofer IDMT.

The researchers are now working on a system aimed at the home user. The main problems to be tackled are the large number of loudspeakers required and the lack of a standardised distribution format. The first problem may be solved with the introduction of new flat loudspeakers. The second may be harder to overcome: the WFS system will only be able to be sold easily into home cinemas (and indeed, into full-scale commercial cinemas) when films exist with suitably-coded audio material, for example to allow the sound of a helicopter to roar through an auditorium. However, such material will only be produced in reasonable quantities when there is enough compatible hardware in existence: a chicken-and-egg situation similar to the one experienced during the introduction of HDTV. Nevertheless, Sandra Brix is confident that there will be WFS systems in living rooms within five to ten years.

(090558-1)

Internet Links

- [1] www.browninnovations.com/sound_domes.html
- [2] www.dakotaaudio.com
- [3] www.yamaha.com/yec/soundprojectors/
- [4] www.pioneer.eu/eur/content/press/news_20021010_PDSP1.html
- [5] <http://en.wikipedia.org/wiki/Intermodulation>
- [6] www.sennheiser.com/sennheiser/home_en.nsf/root/press_archive_2_2001_110aes_2
- [7] www.holosonics.com
- [8] www.atcsd.com/site/
- [9] http://en.wikipedia.org/wiki/Long_Range_Acoustic_Device
- [10] http://en.wikipedia.org/wiki/Sonic_weapon
- [11] http://www.headwize.com/projects/noise_prj.htm
- [12] <http://www.austriamicrosystems.com/eng/Products/Audio/Active-Noise-Cancellation/AS3501>
- [13] <http://www.uni-wuppertal.de/index-en.html>
- [14] http://deposit.ddb.de/cgi-bin/dokserv?idn=969174241&dok_var=d1&dok_ext=pdf&filename=969174241.pdf (doctoral thesis in German)
- [15] http://en.wikipedia.org/wiki/Wave_field_synthesis
- [16] www.idmt.fraunhofer.de/eng/research_topics/wave_field_synthesis.htm
- [17] www.iosono-sound.com/



The new PicoScope 4000 Series high-resolution oscilloscopes

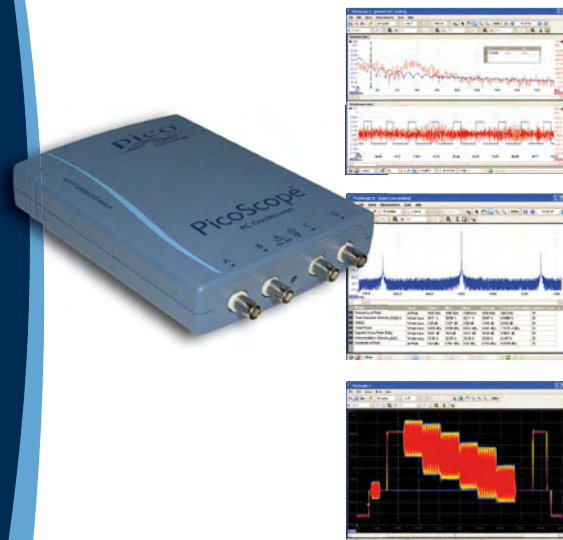

The PicoScope 4224 and 4424 High Resolution Oscilloscopes have true 12-bit resolution inputs with a vertical accuracy of 1%. This latest generation of PicoScopes features a deep memory of 32 M samples. When combined with rapid trigger mode, this can capture up to 1000 trigger events at a rate of thousands of waveforms per second.

- **PC-based** - capture, view and use the acquired waveform on your PC, right where you need it
- **Software updates** - free software updates for the life of the product
- **USB powered and connected** - perfect for use in the field or the lab
- **Programmable** - supplied with drivers and example code

Resolution	12 bits (up to 16 bits with resolution enhancement)
Bandwidth	20 MHz (for oscilloscope and spectrum modes)
Buffer Size	32 M samples shared between active channels
Sample Rate	80 MS/s maximum
Channels	PicoScope 4224: 2 channels PicoScope 4424: 4 channels
Connection	USB 2.0
Trigger Types	Rising edge, falling edge, edge with hysteresis, pulse width, runt pulse, drop out, windowed

www.picotech.com/scope1036
01480 396395

Barometric Altimeter



By C.V. Niras (India)

In this project a piezoresistive transducer measures the atmospheric pressure, enabling a PIC microcontroller to use the ISA model (with temperature compensation) to display your current height above sea level (ASL) on an LCD.

Whereas office managers typically associate 'height' with promotion, career building and a desk on the top floor, everyone else with a healthier mind will be looking up towards the skies, down into chasms or valleys, or for a safe place to land.

When mountaineering, climbing, para-sailing, hang-gliding or flying ULs (ultralights), it's plain essential to know your 'ASL': height above sea level.

Pressure — in theory

Since barometric pressure is closely approximated by the hydrostatic pressure caused by the weight of the air above you, your altitude on the planet above a reference level can be calculated fairly easily and shown on a display. The altimeter described here is

calibrated to show your altitude above the mean sea level (MSL) based on a mathematical model called International Standard Atmosphere (ISA). The ISA model describes the troposphere range with a linear temperature distribution and although that's unlikely to change with time, it does as a function of temperature, with barometric pressure as an inherent dependency. Right, this project does take temperature deviation into account to compensate the altitude reading!

ISA rulez: the components...

For accurate and reliable ASL readings a temperature measurement device has to be included in the project. So let's list the crucial components: a PIC18F2423 microcontroller, an MPXHZ6115A pressure transducer and a digital tempera-

ture sensor type TC77-5.0. Freescale's MPXHZ6115A (**Figures 1 and 2**) is a monolithic, signal conditioned, silicon pressure sensor with an on-chip bipolar op amp circuit and thin film resistor networks to provide a high output signal and temperature compensation from -40°C to $+125^{\circ}\text{C}$.

A fluorosilicone gel isolates the die surface and wire bonds from the environment, while allowing the pressure signal to be transmitted to the silicon diaphragm. With a typical current consumption of 6 mA (at 5 V), it's necessary to keep the sensor in the off state when not in use.

Note that it requires about 20 ms to warm up, i.e. before taking any reading. Maximum error is 1.5% over 0° to 85°C , and the component provides the transfer function

Mountaineers, delta glider and UL pilots — this one's 4 U

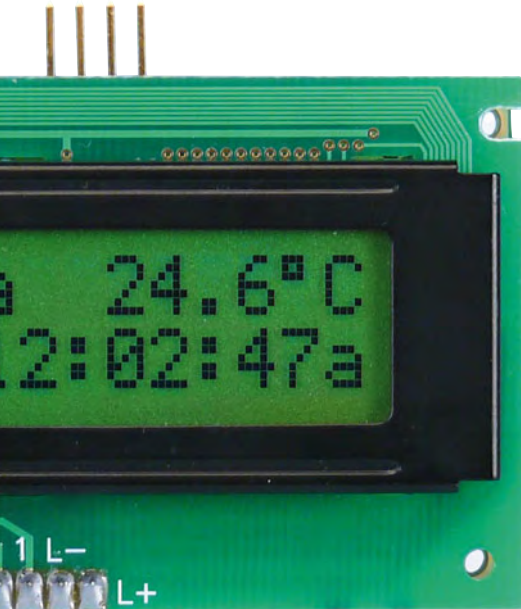

Specification and features

- Altitude range: 0 to 11,000m A(M)SL
- Compliant with ISA model, extended with temperature compensation
- Barometer range: 15 kPa to 115 kPa
- Resolution: 3 m.
- Temperature range: -55 °C to +125 °C
- Real Time Clock
- Supply voltage: 6-15 VDC;
- Current consumption
 - LCD backlight on: 18 mA;
 - LCD backlight off: 8 mA;
 - Standby: 20 µA
- Menu controlled
- Software: C for PIC

$$V_{out} = V_s \times (0.009 \times P - 0.095) \pm (PE \times TF \times 0.009 \times V_s) \quad [\text{Eq. 1}]$$

where P is the applied pressure, V_s is the supply voltage, PE is the pressure error and TF the temperature factor. The output from the pressure sensor is measured using the microcontroller's internal ADC. Altitudes below 11,000 m (33,000 ft) can be calculated using the barometric formula:

$$h = \frac{(1 - (P / P_{ref})^{0.19026}) \times 288.15}{0.0065} \quad [\text{Eq. 2}]$$

where P_{ref} is the pressure at the base (i.e. at MSL), and h the altitude in metres.

The TC77-5.0 temperature sensor from Microchip is a serially accessible digital temperature sensor with a resolution of 0.0625 °C and a maximum accuracy of ± 1 °C within the +25 °C to +65 °C range. Temperature data is available as a 13-bit 2's complement format, and covers a range of -55°C to +125 °C. with a maximum accuracy

of ± 3 °C. A band-gap type temperature sensor, a 12-bit plus sign (13-bit) Sigma-Delta ADC, an internal conversion oscillator (approx. 30 kHz) and an SPI-compatible serial input/output port — the works!

... and the software

The ISA model is based on air pressure at sea level of 101.325 kPa and a temperature of +15 °C. The temperature at 11,000 m is taken to be -56.5 °C, so temperature decreases 6.5 °C for every 1,000 m, up to about 11,000 m. The actual atmospheric temperature can deviate considerably from this model, requiring a correction for altitude readings to be applied.

The temperature correction can be calculated with help of Charles's Law for ideal gases. It states that the volume of the gas is proportional to absolute temperature, or

$$V / T = k \quad [\text{Eq. 3}]$$

where V = volume of gas; T = absolute temperature and k = constant.

For a column of air with base area A and height h , the formula can be written as

$$h \times A / T = k \quad [\text{Eq. 4}]$$

Comparing standard atmosphere with actual conditions, k is still constant and for a column of air with the same base area A becomes a constant, too, and the variations are in h and T . Using index s from the ISA model and r for the real ambient air we can write

$$h_r / T_r = h_s / T_s \quad [\text{Eq. 5}]$$

or

$$h_r = (h_s / T_s) \times T_a \quad [\text{Eq. 6}]$$

The software is written to calculate and solve the above equations and you need not worry about it! C code munchers delve into file **080444-11.zip** available free from the Elektor website! [1]

QNH setting

'QNH' is a Q code rather than the latest PIC mnemonic. It is a pressure set-

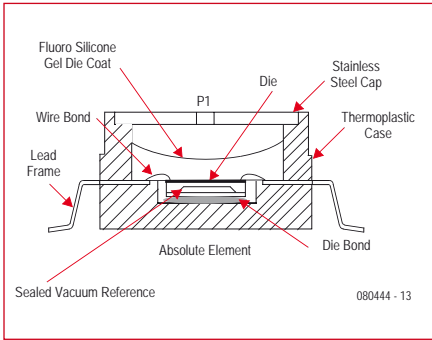

Figure 1. Internal structure of the MPXHZ6115A pressure transducer. (source: Freescale)

phere for the part between the MSL and ground level. It's essentially identical to ISA, but extends the altitude coverage up to 80 km.

You can set the QNH in this altimeter in two ways: either directly enter the QNH using the menu screen, or enter the known altitude for your location.

Circuit description

At the heart of the circuit shown in Figure 2 sits a Microchip PIC18F2423 nanowatt technology, flash microcontroller with 12-bit ADC. The device also sports 16 K code space, 768 bytes of RAM, 256 bytes of EEPROM and an internal oscillator. Here a standard 32.768 kHz watch crystal (X1) with two 15 pF load capacitors are the hardware elements of the (otherwise invisible) real time clock.

Since the pressure sensor, IC4, is ratio-

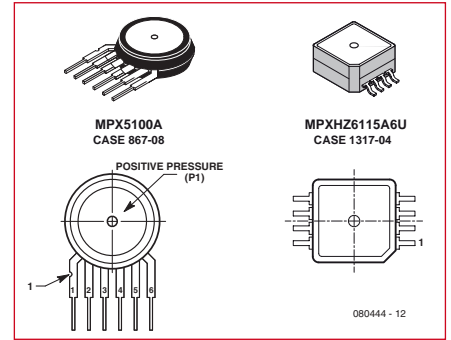

Figure 2. Case shapes of the two pressure transducers that may be used on the Altimeter board. (source: Freescale)

ting used by pilots, air traffic controllers and weather beacons to enable altimeters to read altitude above MSL within a certain region. QNH is calculated from the barometric pressure at ground level using ICAO STD atmos-

metric within the specified excitation range and supplied from the ADC reference terminal, it is not necessary to use a precision reference voltage. The sensor is shut down and woken up using MOSFET T2 on port line RA5.

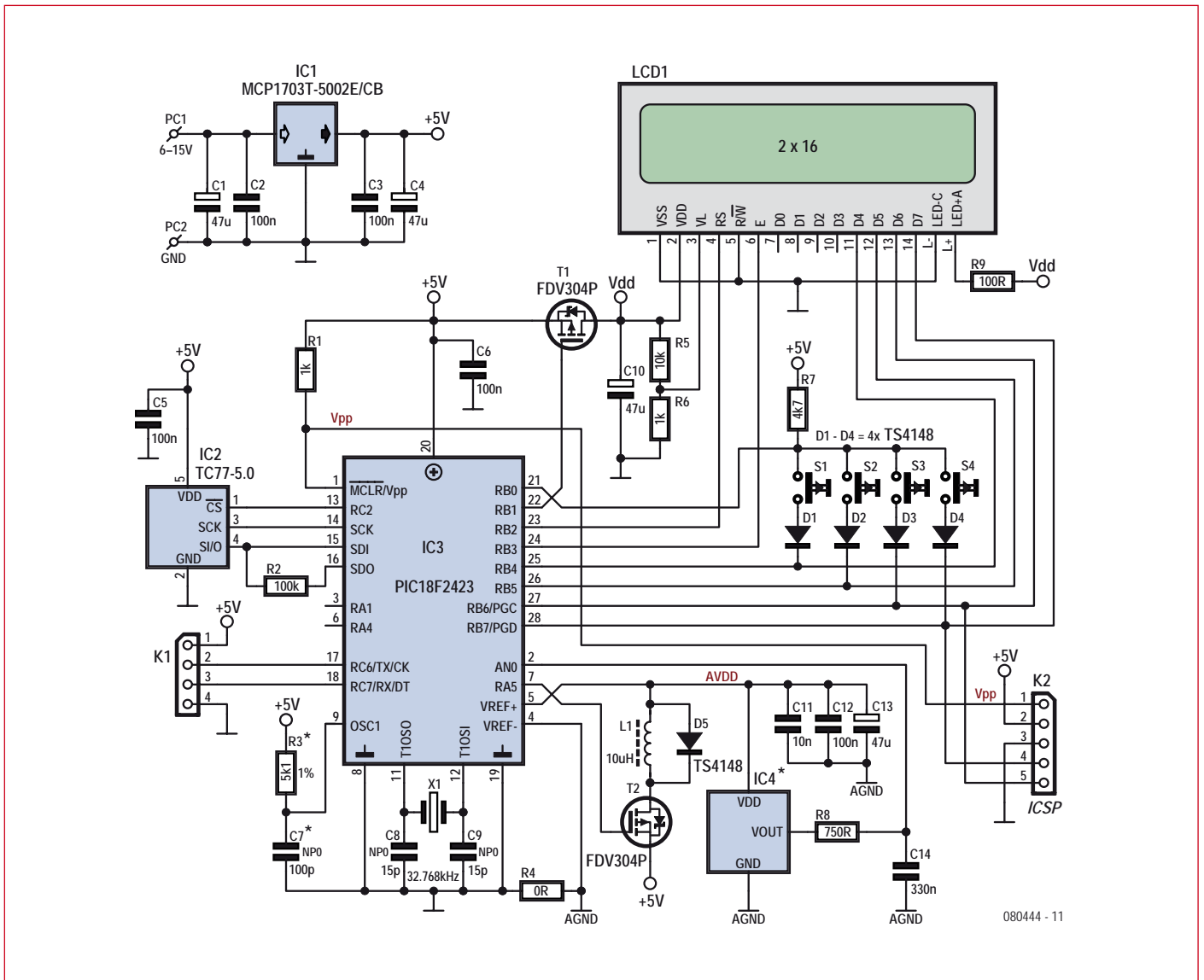

Figure 3. Circuit diagram of the Barometric Altimeter. Note the difference between A(nalog)GND and digital ground.

The pressure sensor output is connected to the microcontroller's ADC channel 0 (AN0) via an RC low-pass filter with cut-off frequency of about 650 Hz. The 750-Ω resistor (R8) allows a low source impedance to be matched to the PIC's on-chip ADC, thus minimising the offset voltage at the analogue input [2][3]. The pressure sensor is supplied via an LC filter (L1, C11, C12 and C13) where D5 is a free-wheel diode.

The LCD is wired to the PIC micro in 4-bit mode, requiring data to be sent twice using the upper nibble of PORTB, with the port also doing the key scanning and multiplexing. Supply power to the LCD arrives via MOSFET T1, which is controlled by port line RB1. Since the PIC has an SPI module, it is not too difficult to get it interfaced to the TC77-5.0 temperature sensor chip (IC2). The TC77-5.0 starts to send data when its \overline{CS} input is pulled logic Low by port line RC2.

The PIC micro may be programmed in-circuit via ICSP connector K2. Push buttons S1–S4 are read in multiplex fashion.

Components R3 and C7 are **not required** with the supplied firmware, because the internal oscillator is being used.

If you do not wish to use the LCD backlight, R9 should be omitted.

The rest of the circuit is no more than the expected low-dropout power supply (IC1) and an array of supply decoupling caps at crucial locations (C1–C4, C5, C6, C11, C12, C13).

Software

The program was written in C and compiled using Microchip's C18 compiler. The PIC can be programmed using simple homebrew programmers like the MultiPIC Programmer [4] and ICProg. Be sure to **disconnect the LCD while ICSP-ing the PIC**.

All is revealed in the C source code file found in archive # 080444-11 supplied for the project. Timer1 is initialised to 0x8000h, causing it to overflow every second. It continues operating in sleep mode (consuming a few microamps only) so it's unnecessary to use an external RTCC chip for timekeeping. The altitude is determined by using Eq. [2] and is displayed along with the atmospheric pressure. The firmware uses 32-bit floating point arithmetic. The conversion starts when the ADGO bit is set, and is cleared after completion of the conversion. After con-

version, the result is available in the ADRESH:ADRESL register pair, and it is right-aligned (i.e. first four bits of ADRESH read as zeros). This 10-bit result can be directly converted to pressure by multiplying it with a constant and adding the pressure offset. The ADC acquisition times for the PIC

The PCB accommodates SSOP cased pressure sensors like the MPXH-Z6115A6U used in our prototype, as well as UP (Unibody Package) through-hole devices like the MPX5100A.

The PCB was designed with two ground planes: one for the analogue part of the circuit (comprising the sen-

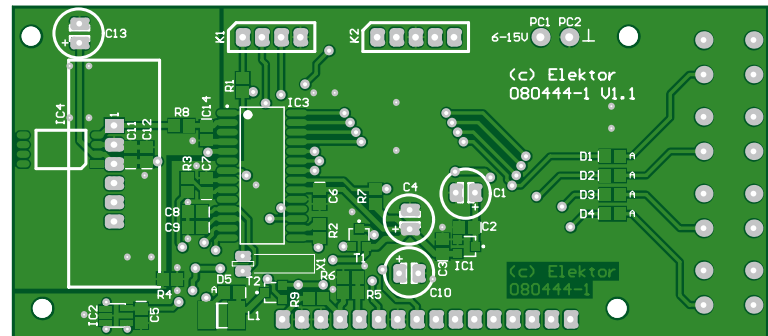

Figure 4. Top side component mounting plan (double-sided board). Copper track layouts available free from www.elektor.com/080444.

COMPONENTS LIST

Resistors

(1%, SMD 0805)
 R1, R6 = 1kΩ
 R2 = 100kΩ
 R3 = not fitted (see text)
 R4 = 0Ω
 R5 = 10kΩ
 R7 = 4.7kΩ
 R8 = 750Ω
 R9 = 100Ω

Capacitors

C1, C10 = 47μF /35V radial electrolytic, lead pitch 2.54mm (0.1")
 C2, C3, C5, C6, C12 = 100nF 50V ceramic, X7R, SMD 0805
 C4, C13 = 10μF 16V radial electrolytic, lead pitch 2.54mm (0.1")
 C7 = not fitted (see text)
 C8, C9 = 15pF ceramic, NP0, SMD 0805
 C11 = 10nF 50V ceramic, X7R, SMD 0805
 C14 = 330nF ceramic, X7R, SMD 0805

Semiconductors

D1–D5 = TS4148, SMD 0805 (Farnell # 8150206)
 IC1 = MCP1703T-5002E/CB, SOT-23, (Farnell # 1439519)

IC2 = TC77-5.0, SOT-23 (Farnell # 1292291)
 IC3 = PIC18F2423, SO-Wide, programmed, Elektor Shop # **080444-41**
 IC4 = MPXH-Z6115A6U or MPX5100A (Freescale), SSOP (see text)
 T1, T2 = FDV304F, SOT-23 (Farnell # 9846123)

Miscellaneous

K1 = 4-way SIL pinheader, right angled solder pins, lead pitch 2.54mm (0.1")
 K2 = 5-way SIL pinheader, right angled solder pins, lead pitch 2.54mm (0.1")
 L1 = 10μH ferrite inductor, SMD 1812 (Farnell # 1174073)
 LCD1 = 2x16, alphanumeric, DEM16217 SYH-PY /V, e.g. Elektor Shop # **030451-72**
 PC1, PC2 = solder pin, 1mm diam.
 S1–S4 = switch, tactile, SPNO
 X1 = 32.768kHz quartz crystal, cylindrical case
 4 PCB supports, nylon, 12mm height, 4.6mm diam. (Farnell # 1325986)
 PCB, ref. **080444-1** from www.thepcbshop.com

micro (i.e. the time required to charge C_{HOLD} in the internal sample and hold circuit) is about 2.96 μs; this must also be observed before taking readings.

Construction

A double-sided through-plated circuit board was designed for the project — see **Figure 4** and pdf file 080444-1 from [1].

sor, RC low-pass filter and the sensor's decoupling capacitors), and the other for the digital circuitry, i.e. the remaining part of the circuit.

The PCB ground planes are interconnected at a single point only by means of zero-ohm resistor R4 (a wire link or a drop of solder is also an option). This bridge provides a single path for return currents. The only necessary trace

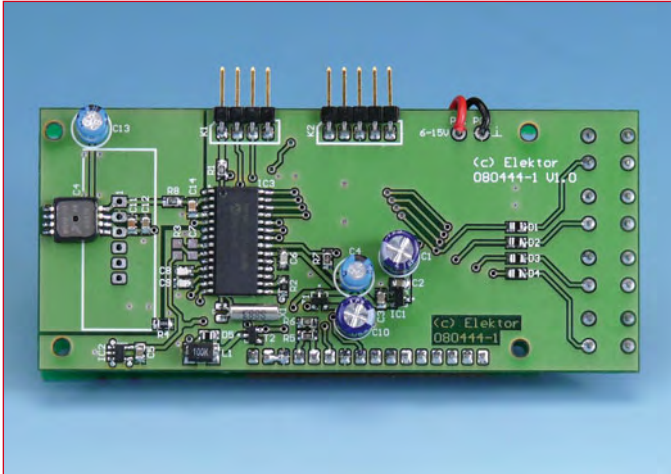

Figure 5. Finished board with MPXHZ6115A SMD pressure sensor mounted at far left of the board.

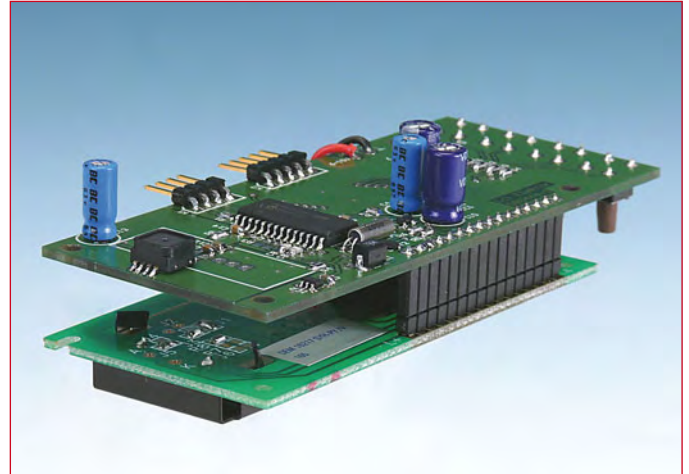

Figure 6. The Altimeter board and the LCD are connected by a 16-way SIL pinheader/socket combination.

that's routed from the digital to the analogue ground plane carries the sensor's supply voltage and is intentionally routed underneath the bridge.

This way we have two equal currents flowing in opposite directions causing the resulting electromagnetic fields to cancel out.

Assuming you've some experience in soldering SMD parts whether reflow-style or manually, the critical ones are the PIC and the pressure sensor. The push buttons and the 16-way LCD connector are mounted **at the top side of the board**.

Run a careful check on your soldering and component mounting before applying power for the first time. All in

Send us photos of the readout at low-oxygen heights

order and your mind at ease, apply power and check if the LCD contrast is as desired. If not, adjust the values of resistors R5 and R6 until you're happy.

For construction standards, the photographs in **Figures 5 and 6** show the levels to match or surpass by your efforts.

(080444-1)

Acknowledgement

The help of Prof. T. K. Mani, Principal College of Engineering Cherthala, India, is gratefully acknowledged.

Internet Links

- [1] www.elektor.com/080444
- [2] http://www.freescale.com/files/sensors/doc/app_note/AN1646.pdf
- [3] <http://www.microchip.com/wwwproducts/Devices.aspx?dDocName=en026428>
- [4] www.hamradio.in/circuits/feng.php
- [5] http://wiki.motionbased.com/mb/Barometric_Altimeter

Practical use

Initially the EEPROM is programmed with typical values of the calibration constants, so apart from the time there's nothing to set unless a solid reference is available for your current altitude.

For the instrument to work correctly, a few calibration adjustments are required. A menu system is provided. Using the four buttons (top to bottom):

Menu / Cursor position

Up / Power On

Down / Power Off

Esc / Save

you can easily set all calibration parameters correctly.

The second function of each key is accessed if the key is held down for about one second.

Enter the menu system by pressing and releasing the Menu button (S1). The first menu item will be displayed on the LCD. To go to next menu, press Up (S2) or Down (S3). To enter the selected menu, press the Menu key again.

The menu contains following items.

Set Pressure: this screen is used to calibrate the pressure sensor.

Set Altitude: this is the first method to set the pressure at MSL. The known value of altitude is entered here. Based on the ambient temperature and pressure, the software will find out the pressure at MSL and save it to memory.

Set QNH: directly enter the pressure for MSL based on QNH information.

Set Time: set / adjust time

To change the value of the selected parameter(s), use the Up (increase) or Down key (decrease) to adjust the value. The underscoring cursor indicates the digit subject to changing, if necessary, by a short press of the Menu key. To exit from the selected menu press Esc (S4).

The altimeter is turned off by keeping the Down key pressed for more than one second. This is actually the power-down mode, and the RTC will continue to keep the time. In this state the processor consumes only minimum power (approx. 20 μ A average for the whole circuit). Switch on again with the Up key.

The World's Lowest Sleep Current MCUs: PIC® MCUs with nanoWatt XLP Technology

Microcontrollers

Digital Signal
Controllers

Analog

Serial
EEPROMs

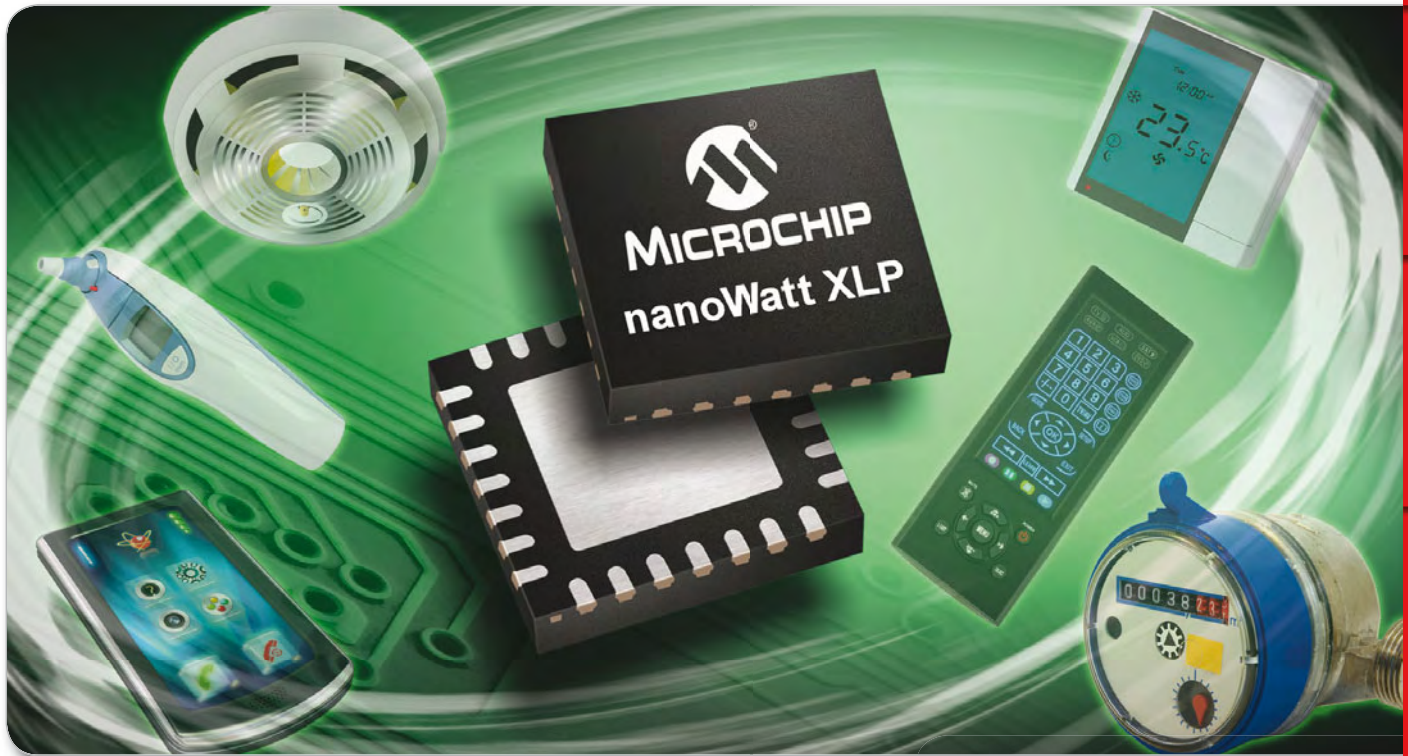

Microchip's PIC® Microcontrollers with nanoWatt XLP Technology offer the industry's lowest currents for sleep, where extreme low power applications spend up to 99% of their time.

- **Extend Battery Life**

- Sleep current down to 20 nA
- Brown-out Reset down to 45 nA
- Watchdog Timer down to 400 nA
- Real time clock down to 500 nA

- **Extreme Flexibility**

- 5 different low power modes to improve power & performance in your application
- Many low-power supervisors, alarms, and wake-up sources

- **Expanded Peripheral Set**

- Integrated USB, LCD, RTCC & touch sensing
- Eliminates costly external components

GET THE MOST FROM YOUR
BATTERY IN YOUR NEXT DESIGN!

1. View the Low Power Comparison demo
2. View free Webinars and Application Notes
3. Download the Low Power Tips 'n Tricks
4. Order samples and development tools
www.microchip.com/XLP



Intelligent Electronics start with Microchip

microchip
DIRECT
www.microchipdirect.com

www.microchip.com/XLP

 **MICROCHIP**

Touch LEDs for Arduino

A cheap 4x4 Monome shield

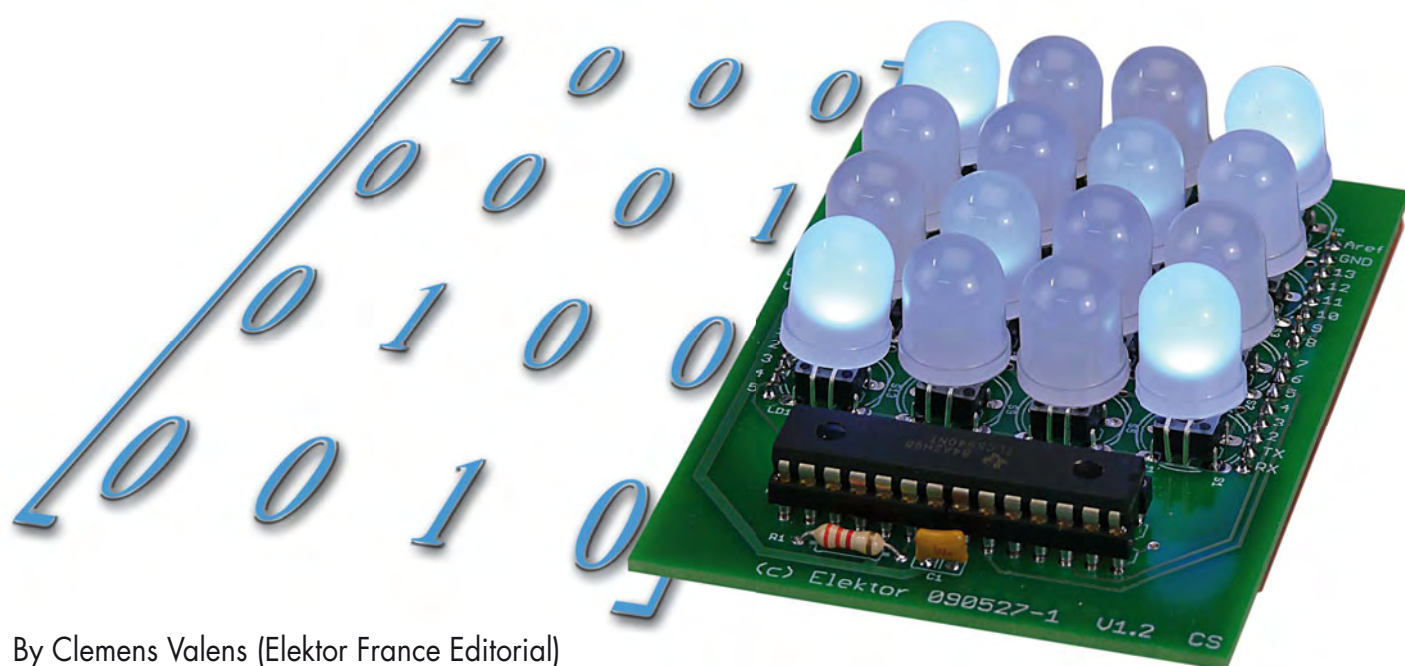

By Clemens Valens (Elektor France Editorial)

Most of the projects published in Elektor simply provide a solution to a problem or fulfil a need. Even though their designers have often tried to propose an elegant circuit or design an attractive PCB, the aesthetic effect of the project itself, if there is one, usually takes second place. One exception is the Monome open source project, a USB luminous matrix keyboard that was designed to be good-looking. Here, it's the application that seems to have been relegated to second place.

Main Specifications

- 4x4 Monome shield for Arduino
- Open source hardware
- 16 push buttons
- 16 LEDs
- TLC5940NT LED controller
- 12-bit LED brightness control

Let's make it clear right from the start: the project shown here is not especially good-looking. It was inspired by the Monome project [2], which is attractive. Even if the design of a genuine Monome may not to your taste, it has to be admitted that the aesthetic aspect of the project is very important — you only have to visit the website to see for yourself.

Exclusiveness seems to be one of the project's other goals. Monomes are

only produced in small runs and their prices are high (expect to pay €/£ 375 or \$500 for a basic Monome) — especially when you think that they are nothing more than simple USB keypads that don't even work with MS Word!

The aim of the project described here is to offer everyone the opportunity to produce their own Monome for a cost that is derisory compared with the price of a 'real' one. What's more, our

Monome can be used for any other purpose, since the software, like the hardware, is open and you can modify everything. The brightness of each LED is 12-bit adjustable, thanks to the LED driver, and we can dream up all manner of fine, luminous objects.

But just what is a Monome exactly?

A Monome is a rather special USB keypad. First of all, the keys, positioned on a grid (usually square, though not necessarily so), do not have predefined functions, and are all identical. In addition, each key is fitted with an indicator that makes it light up.

The Monome communicates with a computer via USB. When we press or release a key, the Monome sends the co-ordinates of the key and its status. The application running on the computer that receives the co-ordinates of the keys decides how to interpret them. And the application also drives the Monome's lights. So the Monome does not control its own lights — it's a bit like a keypad and a display built into the same housing.

Even though a Monome is a USB keypad, it doesn't operate like a standard keyboard and can't be used to replace one. This is because of the communication protocol used by the Monome, which is incompatible with normal keyboards. And there are several different Monome protocols, which makes things even more complicated. Some Monomes include an accelerometer and the communication protocol

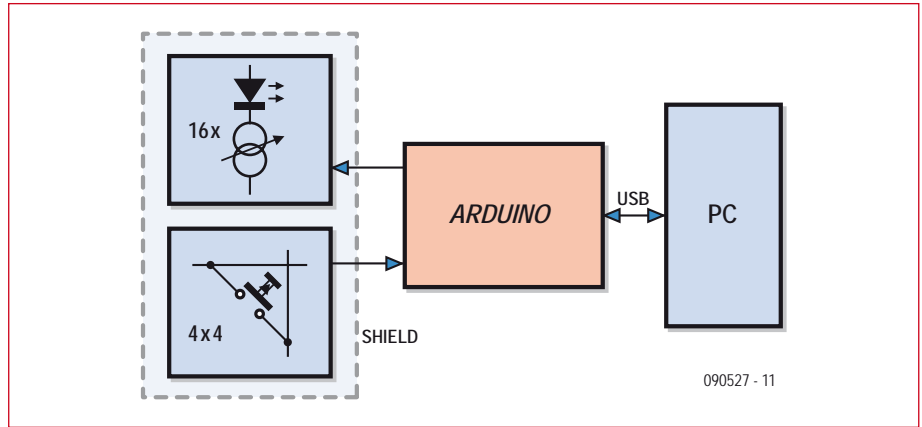

Figure 1. Block diagram of our Monome. Here, 'Shield' doesn't mean screening, but indicates an extension card for Arduino.

allows analogue values to be sent to the computer.

In fact, Monome is the name of the company that developed the keypad, which itself has names like 40h (8x8), two fifty six (16x16), one twenty eight (16x8) or sixty four (8x8). So the name indicates the number of keys. 40h is the hexadecimal value for 64, and so the Monome described in this article is called 10h, as it is based on the 40h, but only has 16 keys.

For those people who like to know everything, Monome is a company that sees itself as minimalist. Its name refers to the monomial matrix, a square matrix that only contains 1's and 0's, with only a single 1 in any given row or column. The company is fairly environmentally-friendly, and its products are manufactured with minimum environmental impact.

OK, I want one!

Once you've understood the concept of the Monome, it's easy to build your own version. All you have to do is assemble a lot of keyswitches around a small microcontroller, and the job is done. This is when you realize that keyswitches with built-in indicators are not very cheap, and that you'll need 16 just for a little 10h Monome. The official Monomes use thermo-formed keypads in transparent silicone. This type of cheap keypad is unfortunately not available to amateurs, who will have to make do with standard illuminated push-buttons at €/£ 3 each. That's why the following project is interesting, because we're going to explain how to make your own illuminated push-buttons for less than €/£ 1! If you are good at DIY and a shrewd buyer, it's possible to build a 10h Monome

Programming the FTDI chip

MProg gives you access to the parameters of the FTDI chip on the Arduino (or other) board, and as you can see, there are quite a few of them! If you're not careful, you risk disabling your USB interface, so don't change any parameters if you don't know what they're for.

MProg can be a bit temperamental. Sometimes, it's impossible to change between editor and programmer modes. It seems that opening or saving a file should clear this blockage. The following procedure seems to work quite well:

- Run MProg
- Connect the Arduino board
- Click **Tools -> Read and Parse**

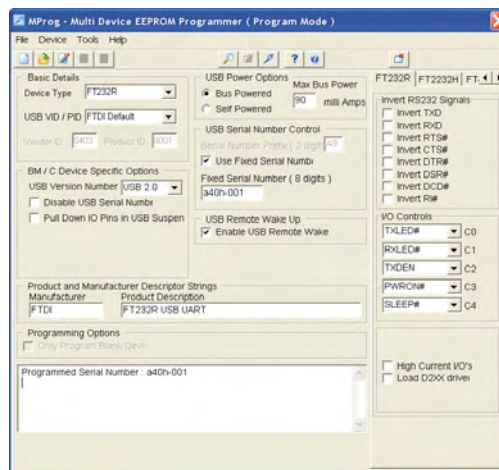

- Check the **Use Fixed Serial Number** box

- Enter an 8-digit serial number starting with 'a40h-' — for example, a40h-001

- Save the configuration: **File -> Save As...**

- Click **Device -> Program**

Everything hangs up for a couple of seconds, then the message **Programmed Serial Number: a40h-001** appears. Your Arduino is now Monome compatible!

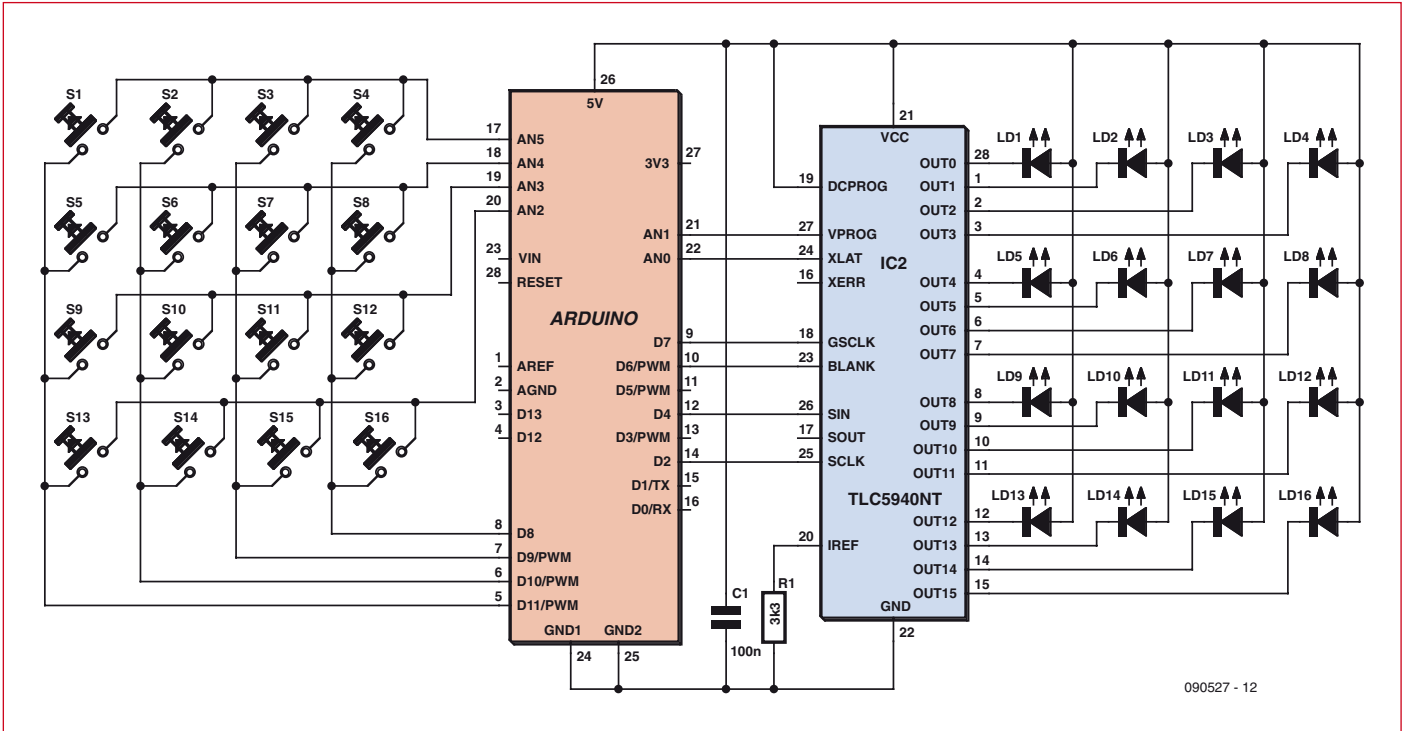

Figure 2. Monome circuit diagram. The Arduino board is based on an ATmega8 or ATmega168, as the PWM function is not used.

for less than €/\$ 35. What's more, the project can be used for other things, as it is just a simple display keypad.

Let's get down to business!

We are basing our design on an Arduino board [3][4], which is inexpensive and easy to program, but you can use a different controller board if you prefer. The only thing that really matters is the USB interface, which absolutely has to be a variant of the FT232R chip from FTDI, otherwise the communication software wouldn't be able to detect your Monome. Because our Monome uses Arduino, it belongs to the family of Arduinomes, which is no pointless distinction, since it requires special software.

You'll find the block diagram of the project in **Figure 1** and the circuit in **Figure 2**. As you can see, it's quite simple, thanks to Arduino and the LED driver IC1. This IC contains 16 current sources for driving 16 LEDs. Each output is controlled by 12-bit PWM (pulse width modulation), offering 4,096 brightness levels per LED. This device has a slightly special serial interface, not very well explained in the data sheet, but which only requires six

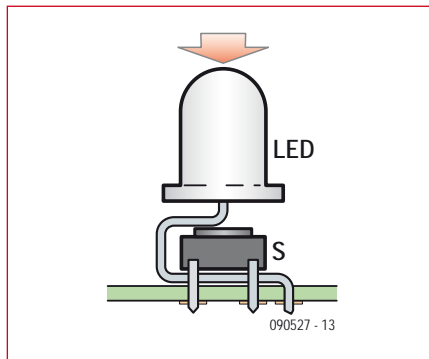

Figure 3. How to construct a touch LED using an LED, a keyswitch, and a little bit of patience.

controller pins. Broadly speaking, the interface is divided into two parts, one for the data transfer and the other for refreshing the LEDs. This interface can be optimised by combining certain signals, but this has not been done here. If you are thinking of experimenting with this device, you may like to know that it lets you adjust the maximum current individually for each output, a nice option that could cause you to waste a lot of time. If you can no longer get one or more LEDs to light up, or if the brightness levels are no longer the same, it could be that you have inadvertently modified the parameters of one or more outputs. In this case, disconnect the power to reinitialize the device — just resetting isn't enough. R1 sets the maximum current for all the outputs, you can select this to increase or reduce the brightness of the Monome overall.

So, these keys?

We're going to construct the Monome keys using 10 mm LEDs and miniature push-buttons (**Figures 3** and **4**). The idea is to use the LEDs to press the push-buttons. The LEDs are large enough to hide the push-buttons, and seen

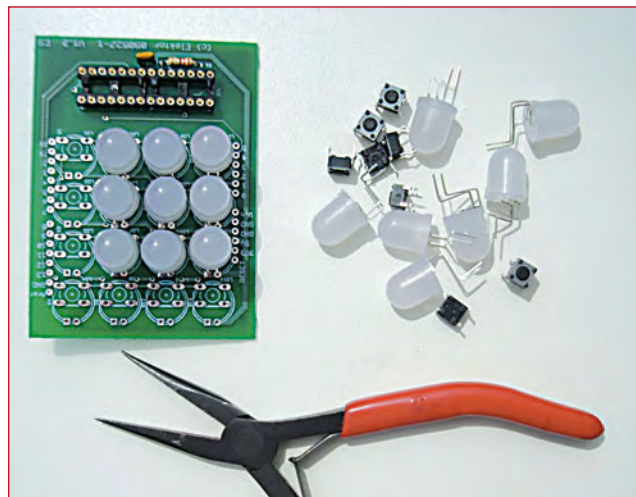

Figure 4. Building the prototype.

from above, only the LEDs are visible. To obtain vertical-action keys, the LED leadouts have to be bent in such a way as to obtain a sort of 'shock-absorber'. Then the push-button is slipped into the shock-absorber and the LED + button assembly is fitted to the board. Concerning the LEDs, before you start making the keys, check that all the LEDs have the same brightness for a given current. It can vary from one LED to another, especially with cheap ones. Don't skip this step, since once the keys have been fitted, it's not easy to remove them again.

Construction

A PCB has been designed for this project [1], see **Figure 5**. In keeping with the 'Open Source' philosophy, you'll find on the web page for this project the complete Eagle file (circuit and PCB) which you can modify as you wish. Take care not to route any tracks beneath the push-buttons on the component side, as the LED leadouts already pass through this space. Start by fitting R1, C1, and IC1. Then fit the keys, starting with the ones in the centre of the grid. Fit the push-buttons carefully horizontal, and try to keep a small space between the LED leadouts and the board to improve the vertical movement of the keys. This job requires a bit of patience and accuracy to end up with a satisfactory result. Finish the wiring with the pin headers that have to be fitted on the solder side of the board.

Initial testing

Two components have to be programmed before the Monome will work: the microcontroller and, surprise, the USB interface! The microcontroller is programmed like an Arduino, since it is an Arduino, and this can be done from the Arduino environment [4], but if you prefer, you can flash the microcontroller directly with the HEX file. You'll find all the source codes and the HEX file at [1].

If you've programmed your circuit with the software available in the article's web page, your Monome now has a demonstration mode that lets us see if the board is working properly. Restart the circuit and watch the LEDs. You'll see first of all that all the LEDs light up briefly: flash! Then the program goes into a loop which progressively increases the LED brightness from zero up to a certain maximum (not the max-

COMPONENT LIST

Resistors

R1 = 3.3kΩ

Capacitors

C1 = 100nF

Semiconductors

D1–D16 = LED, 10mm diam.

IC1 = TLC5940NT

Miscellaneous

S1–S16 = miniature pushbutton, 6x6 mm, e.g. Omron type B3W-1000

2 pcs 6-way SIL pinheader, 0.1" (2.54mm) lead pitch

2 pcs 8-way SIL pinheader, 0.1" (2.54mm) lead pitch

PCB # 090527-1 [1]

Arduino board

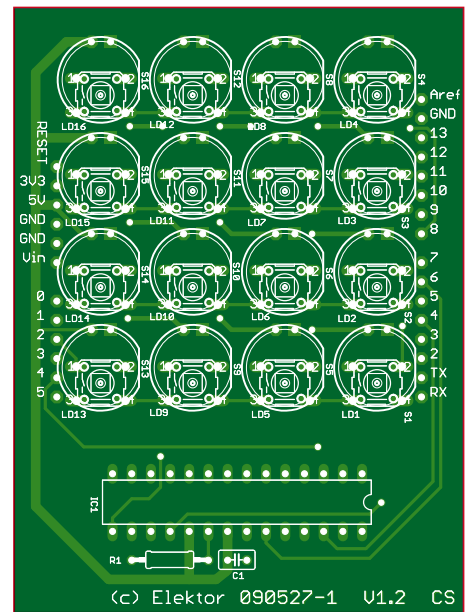

Figure 5. Component side of the PCB.

imum) and then starts all over again. This loop lasts for around 40 seconds or so. If you press on an LED, the brightness of this LED is reset and it restarts its loop. In this way, you can create some hypnotic sequences. The first reception of a Monome command exits the demonstration mode. For the moment, your circuit still isn't a real Monome, so it is unable to receive Monome commands — so let's carry on getting it ready.

As explained above, the FTDI chip also has to be programmed. You may not know it, but this device is programmable thanks to a small EEPROM memory. FTDI provides the MProg tool for doing this [5]. This is necessary in order to make our Monome work with the driver on the computer. In their efforts to make it as simple as possible to use a Monome, the driver's writers

have opted for automatic detection of the Monome by interrogating the USB peripherals; it's not possible to do this manually, which is a bit of a pity. In order to be recognized as a Monome, the peripheral must have a serial number in the format *a40h-xxx* (*xxx* is for you to choose). We adopted *a40h-001*. Refer to the box for details about programming the FTDI chip.

On the computer side...

To finish off our Monome, or rather the operational testing, there are two more pieces of software to be installed on the computer (**Figure 6**). The first piece of software, *Arduinome Serial* [6], is used to translate the Monome communication protocol into MIDI (Musical Instrument Digital Interface [7], a language dating from the 80's, mainly used for synthesizers) or into OSC

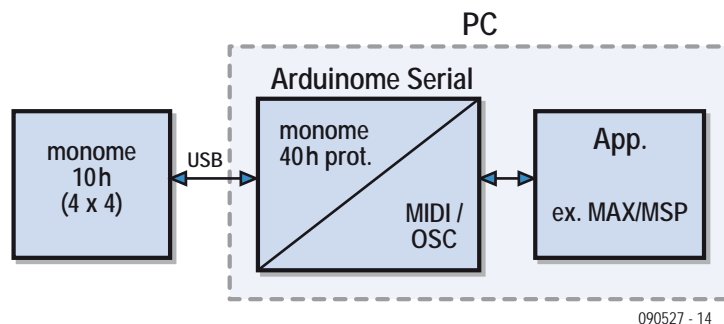

Figure 6. *Arduinome Serial* translates the data sent by the Monome into MIDI or Open Sound Control (OSC). The translated messages are sent to the *Max/MSP* application via the computer's internal network.

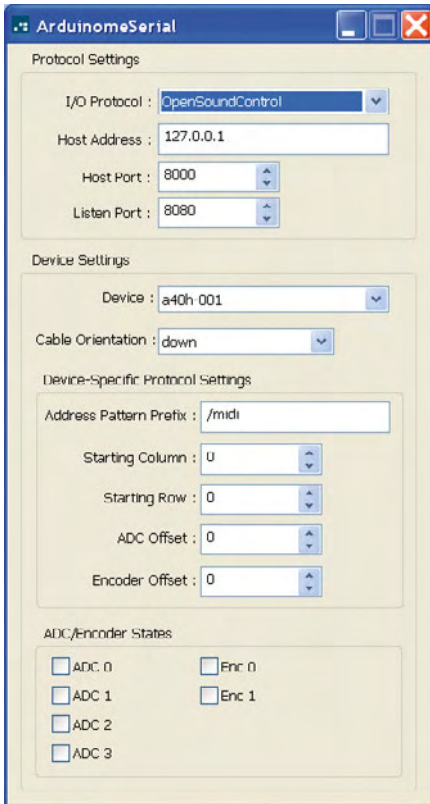

Figure 7. Arduino Serial detects the Monome automatically, and the default parameters are good enough for testing.

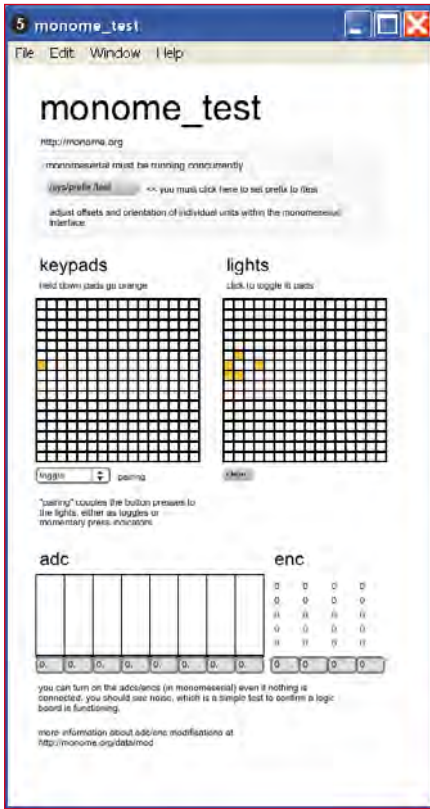

Figure 8. The Monome_test script for Max/MSP lets you check that a Monome is working properly.

(Open Sound Control [8], a language that is more recent, more powerful, and more flexible than MIDI). Arduino Serial has to be used for Monomes based on Arduino or, to be more precise, Monomes that use the FT232R chip for their USB interface. (For the others, there is Monome Serial.) The second piece of software to install is Max/MSP [9] (also see inset). This software is a powerful graphical programming environment for music, audio, and multimedia which is used for developing multimedia patches. The part of the environment that runs the patches (the runtime) is free, which lets you run them on any Mac- or Win-

package from [1] and unzip it onto your computer's hard disk somewhere.

Final testing

Connect the Monome to the computer via a USB cable and run Arduino Serial. If all is well, the software will find the Monome and display the serial number you've just programmed for it (Figure 7). There's no need to modify the parameters for our tests, the default values will do. Now run Max/MSP and load the Monome_test.mxb patch, in the 'Monome base' package (don't take any notice of the messages about matrixctrl). A

Max, Pure Data, jMax

Max/MSP is one of the pieces of music software most used by professional and amateur musicians alike; it lets you synthesize sounds, analyse, and record, as well as controlling MIDI instruments. Originally called Patcher, Max was invented and developed by Miller Puckette at IRCAM in the mid 80's. The first commercial version was distributed by Opcode System in 1990, and Cycling '74 [9] has been looking after its development since 1999. In 1996, Miller Puckette, working at San Diego University, created a free version called **Pure Data**, while IRCAM has developed a free version **jMax** in Java with a graphical interface. There's a substantial community of users and developers around Max/MSP, a collaboration that mainly consists of exchanging 'patches' and 'external' objects, and suggesting improvements to the software. [source Wikipedia]

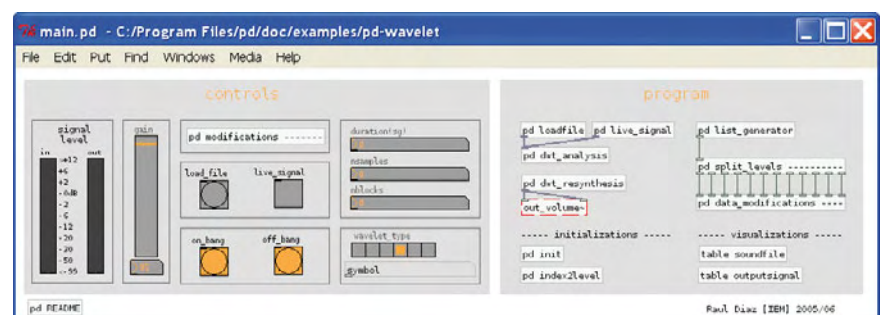

Here's what a PureData patch looks like for breaking down, modifying, and re-synthesising an audio signal using wavelets. The rectangles in the 'program' part are objects that contain sub-programs, the lines between the rectangles are the data flows.

Other music programming languages, albeit without nice graphical interfaces, are, for example, Csound (www.csounds.com) and ChuckK (http://chuck.cs.princeton.edu/).

- Pure Data:** <http://puredata.info/>
- jMax:** http://freesoftware.ircam.fr/rubrique.php3?id_rubrique=2

dows-compatible computer. So download and install just the Max/MSP runtime.

On the Monome website there are some patches for Max/MSP that will enable you to check your Monome is working properly. Download the 'Monome base'

second window opens with two grids in particular (Figure 8), one for the keys ('keypads') and the other for the LEDs ('lights'). Click on the '/sys/prefix/test' button and check that Arduino Serial now displays '/test' in the Address Pattern Prefix box. If so, the two pieces of software are managing

to communicate with each other. Then, in the Monome_test window, click the button next to the word 'pairing', just below the 'keypads' grid, and select 'press'. If you click somewhere in the 'keypads' grid, the corresponding box in the 'lights' grid changes colour. Reboot the Monome. This is necessary because for some reason the automatic detection of the Monome by Arduinome Serial makes the serial link crash. Press the LEDs and you'll see the corresponding boxes in the 'keypads' grid light up. If you have selected 'press', the LEDs will also light up. If you release an LED, it will go out. If you have selected 'toggle', the first press lights the LED, pressing a second time will extinguish it. You can also use the mouse to click in the 'lights' grid to light up or extinguish the LEDs without pressing any keys. If all this is working, you Monome is operational (at last!)

Just to finish off...

If your computer has a sound card, the **Monome_midi_64.mxb** patch will

let you do a test that's a bit more fun. Open the file and click the focus prefix button in the Monome_midi_64 window to change the Arduinome Serial Address Pattern Prefix to </midi>. If you press an LED, you'll hear a sound and you'll be able to play a tune. You can change the sound (the default is piano) and the note values by clicking and moving the mouse around in the matrix.

You'll probably have noticed that the boxes in the 'keypads' grid that light up when you press the LEDs are somewhere in the middle of the grid, and the orientation is not the same as on the Monome. This is due to the Monome software, which doesn't completely follow the convention. Arduinome Serial has a 'Cable Orientation' box that lets you choose between 'up', 'down', 'left', and 'right' — see **Figure 6**. This box is used to orient the Monome with respect to its USB cable. So if you're holding the Monome in your hand with the USB cable coming out downwards, you'll need to choose the 'down' option. It's up to

you to modify the quite simple Monome software to sort everything out, as the options provided by Arduinome Serial aren't enough. Now it's over to you...

(090527-1)

Internet Links

- [1] www.elektor.com/090527
- [2] www.monome.org
- [3] www.arduino.cc
- [4] www.elektor.com/080931
- [5] www.ftdichip.com/Resources/Utilities.htm
- [6] www.sourceforge.net/project/show-files.php?group_id=235473&package_id=285957
- [7] www.midi.org/
- [8] www.opensoundcontrol.org/
- [9] www.cycling74.com
- [10] www.Monome.org/data/app/base

Advertisement



Say It Module (#30080) Provides voice recognition for built-in pre-programmed commands and up to 32 user defined commands! Good for robots, home automation, and more.

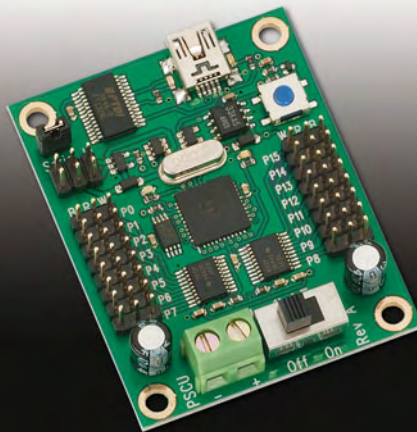

Propeller Servo Controller USB (#28830) Control up to 16 servos with this network-ready module.

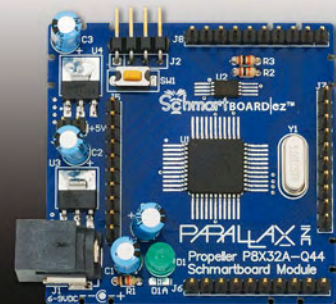

P8X32A-Q44 Schmartboard Kit (#27150) An easy Propeller prototyping system in kit form. Learn surface-mount soldering and then program on this convenient development platform.

New Products from Parallax!

Development boards and accessories to enhance your microcontroller projects.



www.parallax.com

Friendly microcontrollers, legendary resources.

Milford Instruments
www.milinst.com

Spinvent
www.spinvent.co.uk

High-End Audio Amplifier Kits

Build your own valve preamp and power amplifier



By Harry Baggen (Elektor Netherlands Editorial)

In the midst of all the surround-sound and multimedia hype, more and more people are discovering (or rediscovering) the value of a good audio system. This is an area where there is still plenty of room to build your own equipment, including amplifiers and loudspeakers. To make things easier for DIY enthusiasts with limited experience, Amplimo offers high-quality construction kits for a valve preamplifier and power amplifier.

It appears that the interest in good audio reproduction has declined dramatically in recent years. Flashy sound effects seem to have won out over natural stereo reproduction, and everyone is happy with the quality of their MP3 players with their obligatory ear pods, most of which are miserable. What else can you expect when most people are easily satisfied?

Fortunately, we are again seeing a growing interest in high-quality sound reproduction. Unfortunately, the downside is that the necessary equipment is usually rather pricey, but the upside is that you can do a lot yourself in this area. Especially in the high-end realm, people are more inclined to look for refinement in the details than in complex circuitry, which encourages others to make their own modifications or even build (or copy) complete amplifiers. However, not everyone is able to do this.

If you enjoy the idea of building your own high-quality amplifier without and saving a pot of money at the same time, you should certainly have a look at the preamplifier and power amplifier kits described here. These are valve amplifier designs from the hand of Menno van der Veen,

which are sold in kit form by Amplimo. In the audio world, Menno van der Veen is primarily known as a specialist on the subject of output transformers and valve amplifiers. He also conducts workshops and master classes on valve amplifier design. A few years ago he developed a valve amplifier for DIY construction, which since then has established a good reputation among hi-fi enthusiasts. There was also a version of this amplifier as a pure power amplifier, without a volume control or selectable inputs. Naturally, a power amplifier of this sort needs a matching preamplifier, and it also appeared recently. This was sufficient reason for us to have a closer look at the combination of the MCML05 and UL40S2P units.

Complete kits

The kits for these two amplifiers include all of the necessary parts, nicely sorted and packaged in several bags: PCBs, components, connectors, screws, wires, and even cable ties and safety labels. The valves (some of them selected) are packaged separately and numbered. Each kit also includes a machined enclosure with pre-fitted threaded bushes and a

separate front panel (plastic or metal). The detailed assembly instructions (around 65 pages for the preamplifier and 40 pages for the power amplifier) are located in a folder. The construction of each amplifier is described step by step, and the approach is so clear that it's practically impossible to go wrong. Of course, you do need to have some technical knowledge and know how to use a soldering iron. Each project begins with the assembly of the circuit boards. All of the components of a particular type are fitted in each step, such as the solder lugs, followed by the resistors, then the diodes, and so on. The instructions explain what these components look like, how to make sure that you get the polarity right, and the value marked on each component. For anyone who's an old hand at electronics this is all a matter of course, but there's many an audio enthusiast who knows little or nothing about electronics. After all the PCBs are assembled, the next task is the mechanical assembly, such as fitting the circuit boards in the enclosure and connecting the wiring. Here again the instructions are very detailed; every length of wire and piece of heat-shrink tubing is described and shown in a drawing.

After this is finished, you can start the process of testing and adjusting the amplifier. In each of the instruction manuals, Menno van der Veen provides suitable explanations of the design and design philosophy of the amplifier. In the case of the preamplifier, there is also an extensive discussion of how to use the input transformers with a moving-coil (MC) cartridge. There are also various suggestions for modifications to the preamplifier and the power amplifier.

MCML05 preamplifier design

When developing the concept for the preamplifier, Menno van der Veen was clearly more interested in sound quality than technical perfection (i.e. minimal distortion). The signal path of the MCML05 is very simple and consists of a volume control and a balance control (both from Alps) followed by a buffer stage consisting of two triodes in a sort of SRPP configuration. Clearly a minimalist design, intended to have minimum effect on the signal passing through. This preamplifier is perfect for vinyl enthusiasts, since the MCML05 includes a two-stage MD preamplifier with a passive RIAA compensation network (see **Figure 1**). To allow it to be used with moving-coil (MC) cartridges, there are two

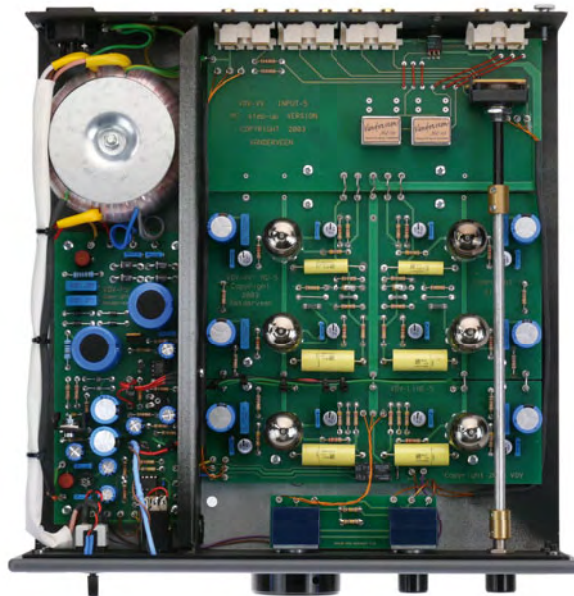

Figure 1. Interior view of the MCML05 preamplifier. The special MC transformers can be seen at the rear, next to the input connectors.

special step-up transformers (also designed by Menno) to boost the weak MC signal by a factor of 10 before it goes to the input of the phono stage.

The power supply is built entirely using semiconductor devices and has a switch-on delay to ensure that the filament voltage first builds up slowly over an interval of 15 seconds. After this, the high voltage is switched on and reaches its maximum value after around 30 seconds. The power supply board also hosts a headphone amplifier built around a TL072 dual opamp.

Figure 2 shows the interior view of a fully assembled preamplifier.

UL40S2P power amplifier design

In the preamplifier, the circuitry is spread over five PCBs, but in the power amplifier it is all located on a single, relatively large circuit board. The mechanical layout is traditional, with the valves and transformers fitted on top of the enclosure (see **Figure 3**). For safety, they are covered by a protective hood.

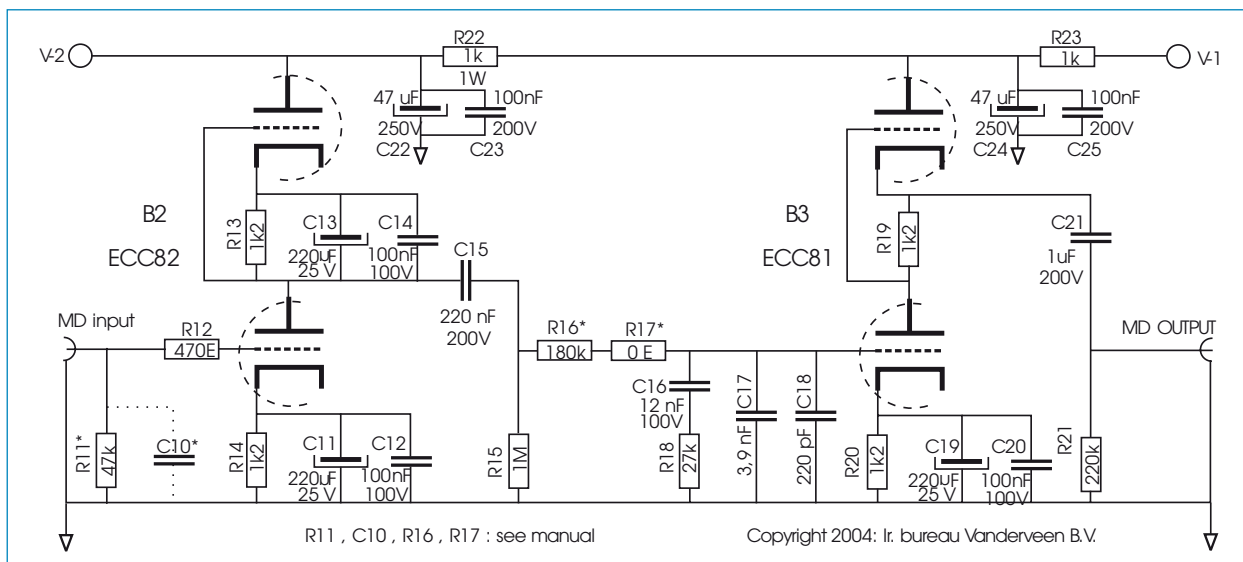

Figure 2. Schematic diagram of the phono preamp. The RIAA compensation network is entirely passive.



Figure 3.
The UL40S2P power amplifier with its protective cover removed.

Just like the preamplifier, the power amplifier has been kept strictly minimalist and does not employ any overall negative feedback (see **Figure 4**). The circuit consists of a phase splitter built around a 6922 and a balanced output stage with a pair of EL34s (6CA7s), which are connected to a special toroidal Vanderveen output transformer. The power transformer is also a toroidal type.

The amplifier can be wired in various configurations (triode, ultralinear and pentode), which gives enthusiasts extensive opportunities for experimentation.

The UL40S2P delivers approximately 30 W per channel in the pentode or ultralinear configuration. The output power in the triode configuration is half this value.

The power amplifier has a standby switch so the high voltage can be switched off while leaving the filament voltage on. This dramatically reduces the aging of the output valves and allows the amplifier to be used immediately at any time without a long warm-up interval.

In addition to the various output stage configurations, with this amplifier you can experiment with other types of driver valves and output valves. There is an optional output transformer with windings made from silver wire, although this represents a considerable investment in comparison with the overall price of the kit.



Figure 4.
Bottom view of the power amplifier. All of the circuitry, including the valve sockets, is located on a single PCB.

Measured results

Despite the fact that sound quality ultimately plays a greater role than technical specifications in the concept of these amplifiers, as engineers we could not resist the desire to connect them to our Audio Precision System II analyser and have a look at the figures.

Here we describe some of the results, with comments.

The distortion of the preamplifier and the power amplifier is not especially low, but you can hardly expect low distortion from a valve amplifier without negative feedback. **Figure 6** shows the distortion spectrum of the power amplifier at an output level of 1 watt into an 8 Ω load. Here the THD plus noise is approximately 0.4%. This is an acceptable value for an amplifier design of this sort without negative feedback. Some mains hum from the power rail can be seen at the bottom end. With our unit, the maximum output power was 23 W per channel into 4 Ω , with a distortion level of 3%. However, in this connection we should note that the mains voltage in the lab of our castle is on the low side, so the figure will probably be higher in most home settings. The bandwidth of the power amplifier is decently large at around 85 kHz, with the lower 3-dB point well below 10 Hz. All of these results were measured in the ultralinear configuration.

The damping factor of the power amplifier is only 5 (with an 8- Ω load), which is fairly low. This is primarily due to the designer's resolution not to use overall negative feedback in the amplifier. Although this is a noble aim that can certainly benefit the sound quality of the amplifier, it can also create difficulties when driving loudspeakers because they generally have very complex impedance characteristics. In combination with the output transformer, the speaker impedance yields a curve such as that shown in **Figure 7**. In practice, this means that the frequency response of the speaker is affected by the impedance curve, which can lead to deviations of up to several decibels. The resulting sound image is entirely different from that of an amplifier with a higher damping factor, but this ultimately has nothing to do with 'valve sound'. Consequently, it is advisable to use the UL40S2P with loudspeaker systems that have a flat impedance curve or loudspeakers equipped with impedance correction networks.

The rated sensitivity of the preamplifier is 220 mV for a 1-V output signal, which is the signal level necessary to drive the power amplifier to its maximum output power. The distortion is 0.3% with an output level of 1 V and decreases to approximately 0.1% with the volume control set to an overall gain of 1. The accuracy of the phono stage is very precise. The deviation from the standard RIAA characteristic is less than 0.2 dB between 50 Hz and 10 kHz, and less than 0.7 dB over the range of 20 Hz to 20 kHz. The signal to noise ratio and hum from the line inputs of the preamplifier are both at a nice level of -76 dB (lin.). The sensitivity of the MD input is 7.6 mV, while the sensitivity of the MC input is 720 μ V (both for 1 V out). Especially for the MC input, it is best to choose an MC cartridge with a relatively high output voltage for use with the MCML05.

Listening results

After a few days of playing with the various options, we listened to the combination of the two amplifiers along with a Sony SADC player and a set of B&W 803 speakers. The spaciousness of the reproduced music was striking with this combination. The overall sound image proved to be a good deal further away from the listener, being located more

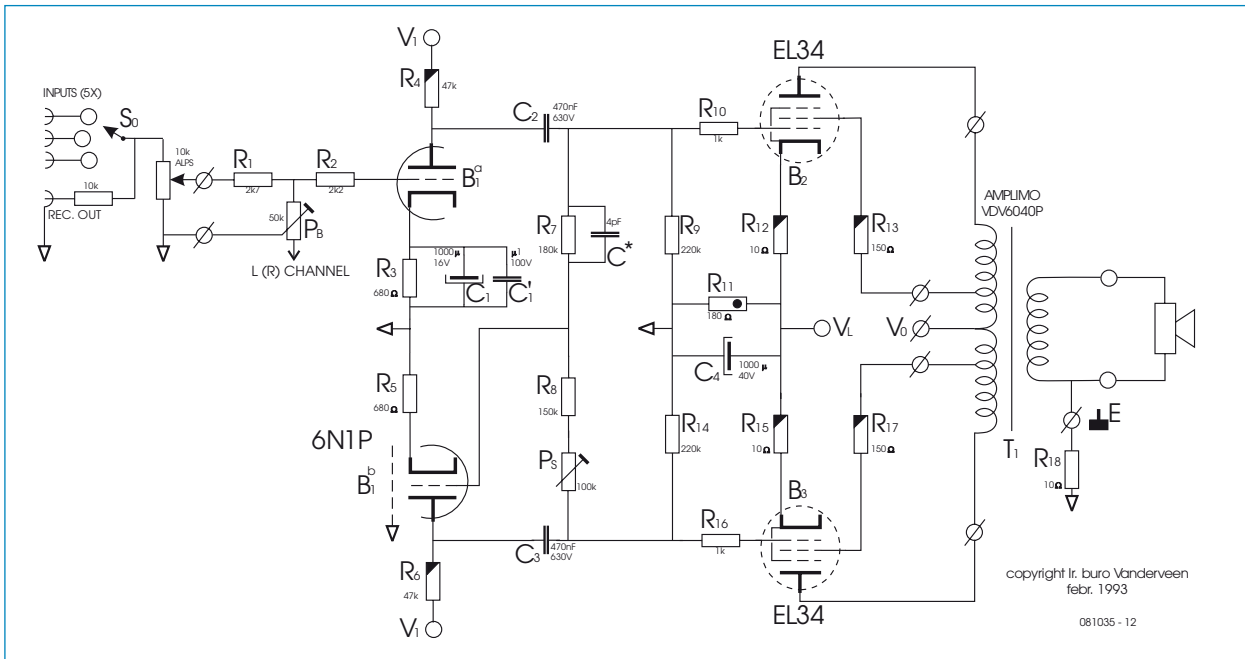

Figure 5. Schematic diagram of the power amplifier, which can be wired in various configurations (triode, ultralinear or pentode) by making small modifications.

behind the loudspeakers than with the transistor amplifier we normally use in this system. Remarkably, we found that the treble reproduction had slightly more presence than with the transistor amplifier, which is the opposite of what you would expect. This resulted in increased detailing in the reproduction.

The bass reproduction remained controlled under all conditions; apparently the low damping factor does not have any adverse effect in this regard. However, this can vary from one loudspeaker to the next. At higher volume levels, the transistor amplifier delivered distinctly more pressure in the bass region, but this difference may be due to the modest output level of the Amplimo power amplifier.

All in all, we can say that the MCML05 and UL40S2P form a combination that can give audio enthusiasts a whole lot of listening pleasure, in part due to the many configuration and tuning options.

Conclusion

The design and construction of both of these amplifiers are well conceived. We can recommend these kits without reservation to serious audio enthusiasts who want to try a valve system. Menno van der Veen has devoted a lot of time not only to the technical development of these amplifiers, but also to optimising their sound quality. This can be seen in the choice of components, the layouts of the circuit boards, and the quality of the connecting cables. The kits even include silver solder for the solder joints.

Neither of the kits can be regarded as inexpensive, but this will certainly not form a hindrance for serious audio enthusiasts – especially when you consider that a ready-made valve combo (preamplifier and final amplifier) of this quality costs at least twice as much.

(081035-1)

Additional information:

www.amplimo.nl
www.mennovanderveen.nl

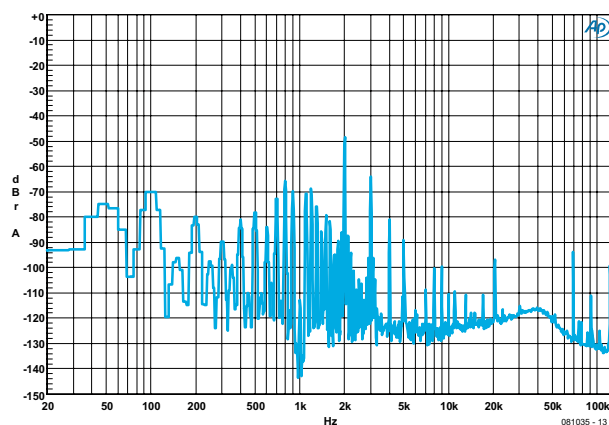

Figure 6. FFT distortion analysis at 1 kHz with 1 W into 8 Ω.

Vanderveen MCML05 preamplifier:

kit price € 1245 (approx. £ 1080).

Vanderveen UL40S2P power amplifier:

standard kit price € 1295 (approx. £ 1120).

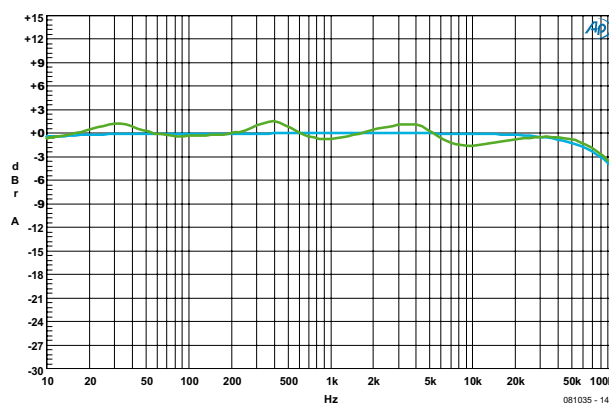

Figure 7. Frequency response of the power amplifier. The upper curve shows the frequency response with the amplifier connected to a real loudspeaker.

Car Tilt Alarm

Protect your alloy wheels

By Mickael Bulet (France)

This project is aimed at all those who have fine alloy wheels on their car and are worried about finding it propped up on bricks. Whether you already have a car alarm or not, this project could be used in conjunction with that, or stand alone. This alarm has been designed to be adapted to your needs and is easy to use thanks to the built-in installation aid.

The car alarm described here detects changes in the tilt angle of the vehicle in which the alarm is installed. It is set off when the change in the angle exceeds a threshold (adjustable) for too long (5 seconds). Short of cutting the power to it, the only way to stop the alarm is to put the car back to its initial angle. The change in angle to which the alarm is sensitive can be adjusted from 0 to 25°.

Hardware

The alarm is built around a PIC16F877 microcontroller (Figure 1). A dual-axis accelerometer connected to the controller's port-A analog input is used as a tilt angle detector. In a static situation, it will output a DC voltage on the X and Y axes depending on the angle it is at with respect to the horizontal. The accelerometer is an ADXL322 [1] from Analog Devices, pre-fitted to a small board, as the device is tricky to solder by hand.

The alarm is configured using jumpers on three 2×4-contact pinheaders and four switches connected to the controller's port B. The headers are OR-ed

together via the diodes (D2–D9 and D12–D15) and require only four inputs. They are multiplexed using three outputs from port C.

Four other outputs from port C are used to drive three LEDs and a relay, buffered by a ULN2803, powered from 12 V to avoid excessive loading on the 5 V rail. The ULN2803 works out cheaper and above all less cumbersome than a solution using transistors. The LED driven by RC3 shows if the system is armed, the other two LEDs are used by the installation aid for leveling.

Pin PC7 is used as an input for arming the system. This input is opto-isolated and filtered by R7 and C7; R5 limits the current in the opto-isolator's LED. In this way, a permanent +12 V available in the passenger compartment can be used, and only one wire to the alarm is needed, instead of two wires if the 5 V rail were used, with a greater risk of interference too.

The other PIC ports are not used. While developing the program, port D was

used for displaying parameters with the help of an EasyPIC4 board from Mikroelektronika [2].

The power for the alarm is taken from the vehicle, either from a permanent + rail, or directly from the battery. Don't forget to include an in-line fuse to protect the circuit. A quick-blow 100 mA fuse will be enough if the circuit doesn't have its own siren, but if used as a stand-alone alarm, you'll need to allow for the extra current drawn by the siren.

The 5 V supply is perfectly standard, with D1 protecting the regulator from reverse current when the system is shut down completely.

Software

The firmware was written in mikroBASIC [2] and is small enough to be com-

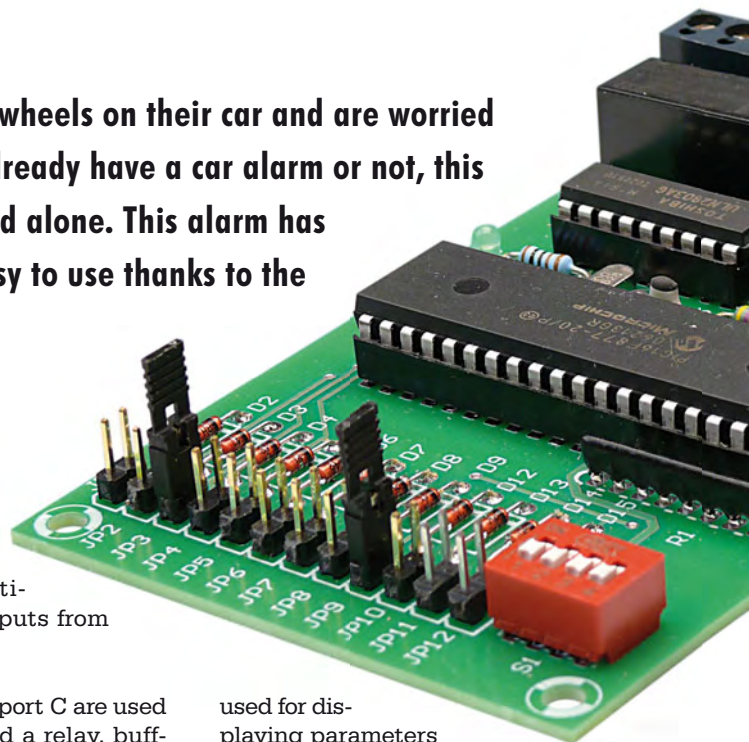

Disturbing the peace

Alarms have a tendency to go off at random both day and night, with no thought for the neighbours.

In some countries, this type of sound nuisance is punishable under laws addressing disturbances of the peace at night. In a few countries, car alarms with sirens are even prohibited. Consult your local legislation.

Technical Specifications

- trigger angle: 0–25°
- operating time adjustable 0–165 s;
- two activation modes:
intermittent @ 0.5 Hz or continuous
- built-in installation aid.

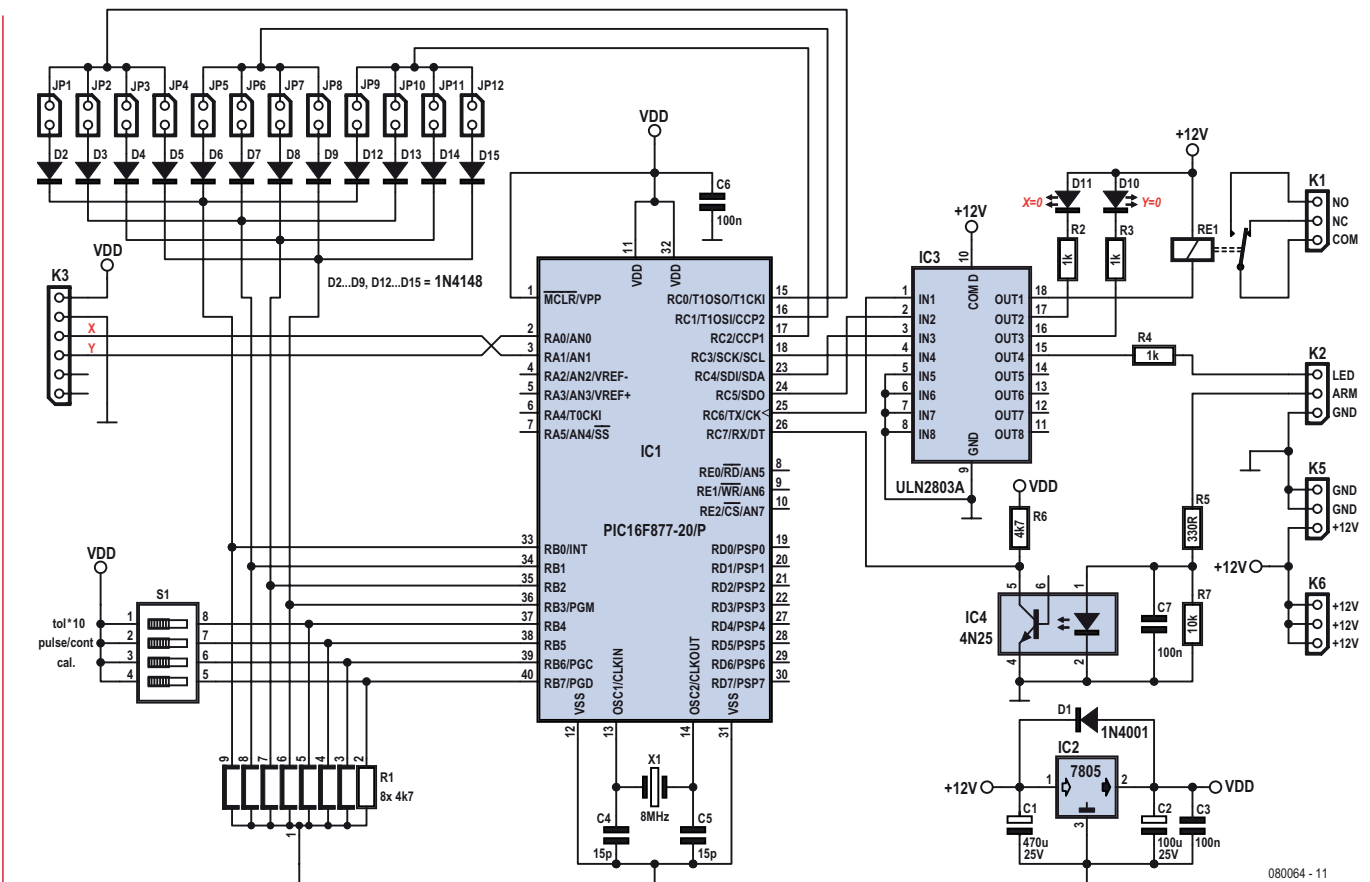

Figure 1. Alarm circuit diagram.

piled using the demo version of the compiler. The software consists of two sub-programs: the vehicle installation aid and

the alarm proper. The choice between the two programs is made using switch S1 3-6 on the RB6 line. The installation aid is enabled when RB6 sees a logic

High. **Figure 2** shows the flow diagram of the program.

In normal mode (alarm), the settings on the headers are read at the start of the program. To read a header, the corresponding output of port C must be taken High and the hex-coded data is input to port B. The other port C outputs connected to the other headers must remain low. By way of an example, here's how the alarm triggering time is read:

Reading the units

- RC0 to 1, RC1 and RC2 to 0
- delay of a few milliseconds for the values to stabilize
- data read at port B
- four MSBs suppressed
- data obtained stored in memory

Reading the tens

- RC1 to 1, RC0 and RC2 to 0
- delay
- port B read
- four MSBs suppressed

Trigger time = 10 × tens + units

This process makes it possible to read four headers using one 8-bit port: the four MSBs as an Enable output for the headers and the four LSBs for reading the data. Masking via an AND will suppress the four MSBs from the read data.

After reading the operating parameters, the program waits in a loop for RC7 to be taken to 1 before going into 'armed' mode. Once armed, the 'real' surveillance will only start after a 10-second delay — the time to get out of the vehicle and allow it to stabilize. The current angular position of the vehicle is then stored in memory and the alarm trigger values are calculated. In this way, you can leave the vehicle at any angle, and when the alarm is armed, the current value will be taken as the reference for the calculations. The trigger thresholds (lower and upper) depend on jumpers JP9–JP12 for angles from 0 to 15° and switch S1 1-8 which lets you add another 10°. Hence we get an adjustment range from 0 to 25°.

Now the program goes into a loop, from which the only way out is when one of the two thresholds is exceeded, or the system is put into standby mode. If one of the two thresholds is exceeded for some reason, the software will wait 5 seconds before confirming the threshold is still being exceeded. This

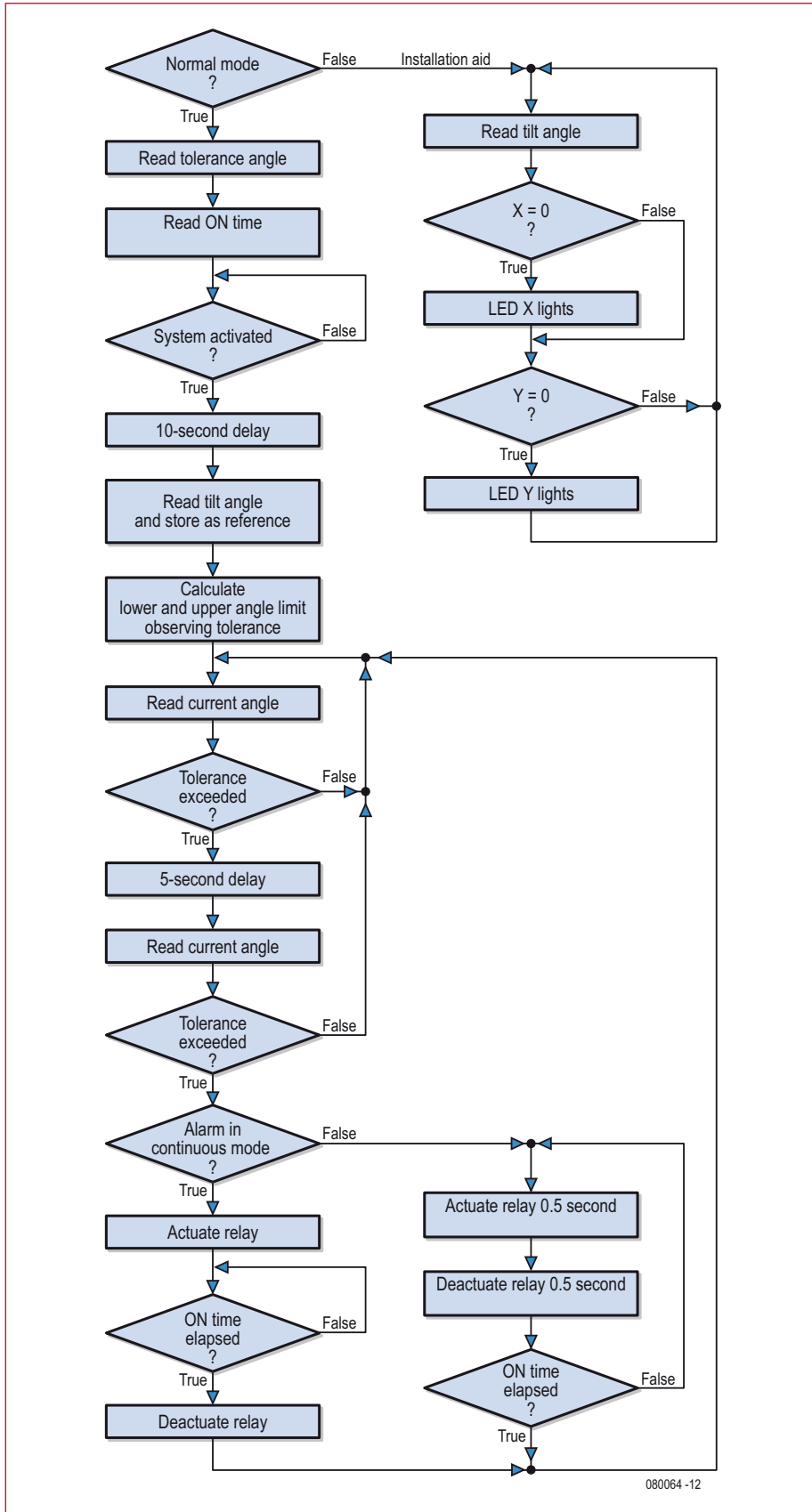

Figure 2. Software block diagram.

precaution will avoid unwanted triggering caused by a slight impact, a gust of wind, or a passing truck. Even in Formula 1, five seconds is a bit short for lifting up the car, removing the four wheels, and putting the car back into its original position!

If the second tilt check confirms that the angle of the vehicle is out of limits, the alarm goes off.

There are two options for operating the output relay (S1 2-7): continuous operation throughout the time programmed by the jumpers, or intermittent operation (0.5 Hz) for the programmed time.

Once an alarm cycle has been completed, the program goes back to the first tilt checking loop. If in the meantime the car has returned to its original position, the alarm will stop.

Of course, the system can be put into standby at any time, even while the relay is operating.

Table 1. How to set the jumpers to obtain specific values.

JP4, JP8, JP12	JP3, JP7, JP11	JP2, JP6, JP10	JP1, JP5, JP9	Value
-	-	-	-	0
-	-	-	fitted	1
-	-	fitted	-	2
-	-	fitted	fitted	3
-	fitted	-	-	4
-	fitted	-	fitted	5
-	fitted	fitted	-	6
-	fitted	fitted	fitted	7
fitted	-	-	-	8
fitted	-	-	fitted	9
fitted	-	fitted	-	10
fitted	-	fitted	fitted	11
fitted	fitted	-	-	12
fitted	fitted	-	fitted	13
fitted	fitted	fitted	-	14
fitted	fitted	fitted	fitted	15

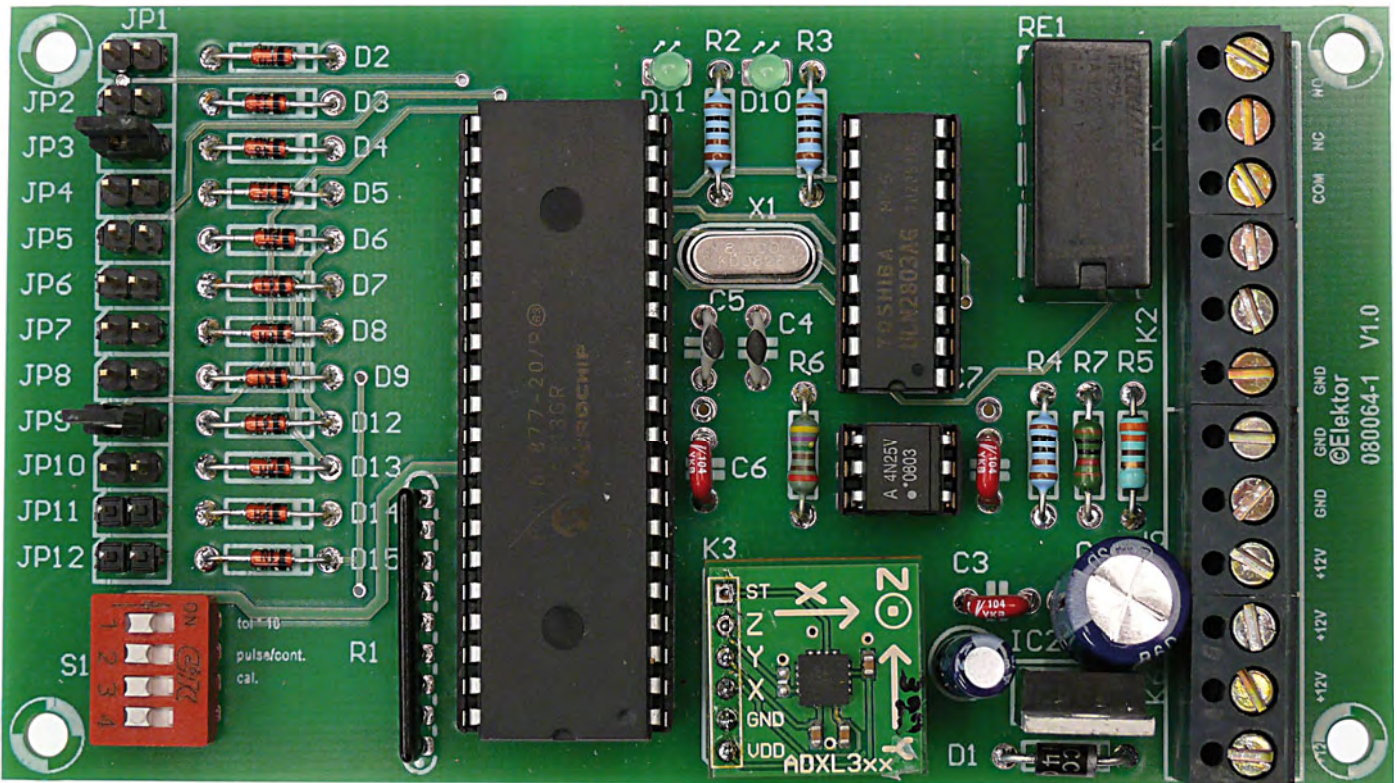

Construction

You can build this project in your usual manner.

Note that the accelerometer will need to be fixed in such a way that it doesn't vibrate while the car is moving. To achieve this, one pad has been

Table 2. Functions of the S1 switches.

Switch	Open	Closed
S1 1-8	threshold +0°	threshold +10°
S1 2-7	intermittent alarm	continuous alarm
S1 3-6	normal mode	installation aid mode
S1 4-5	-	-

Adjustments

Note that changes in the jumper or switch positions must be validated by resetting the circuit, which means cutting the power for a few seconds, as there is no reset button. See Tables 1 and 2 for how to position the jumpers and switches.

Setting the trigger threshold

The trigger threshold is set by jumpers JP9–JP12 for angles from 0 to 15° and switch S1 1-8 which lets you add another 10°. Hence the threshold can be set between 0 and 25°, though it's better not to go below 2°, as possible drifts in the accelerometer or PIC's analog/digital convertor voltages could result in unwanted triggering.

Setting the alarm time

The alarm time is set by JP1–JP4 ('units' 0–15) and JP5–JP8 ('tens' 0–15) from 0 to 165 s, i.e. 2 min 45 s, which seems to be more than enough, given that the alert is continued (after around 5 s) if the vehicle fails to return to its original position. When using this circuit in conjunction with an existing alarm, select 1 s maximum. This is more than enough for it to be detected by a alarm.

Setting the relay operating mode

Use S1 2-7 to select the relay operating mode: continuous or intermittent. This choice will be determined by the type of wiring and the siren you are planning to use. For a siren with a modulated output, choose continuous mode. Use continuous mode when using this circuit in conjunction with an existing alarm.

provided on one end of the accelerometer (opposite the row of contacts) for soldering a loop the end of a piece of stiff wire. This can then be connected to the accelerometer board.

The two large filter capacitors (C1 and C2) should be soldered as close as possible to the PCB, and if necessary held in place with a big blob of hot-melt glue. All this is intended to protect

against vibration, which might break the soldered connections and cause false contacts.

Bolt the regulator IC2 onto the PCB.

Installation

The alarm must be powered from a permanent +12 V supply via an in-line car fuse (so that the device can be turned

off externally, to save having a master switch, and to protect against possible shorts) and a ground connection made to the chassis or a grounding point on the car.

All wires should be at least AWG17 c.s.a. and should be run inside plastic sleeving (you may be able to use domestic 6.25 inch diameter flexi-

Connections

This alarm was designed to be used either in conjunction with an existing system that already monitors the opening of the bonnet, the boot (trunk), breaking into the passenger compartment, or engine starting, or on its own, with the addition of a simply 12 V siren.

Wiring as an auxiliary to an existing alarm

The unit will be armed either by a separate switch concealed in the passenger compartment, or by the main alarm itself. To achieve this, most alarms have a contact that makes when they are armed, for connecting a relay to cut the power to the fuel pump (immobilizer!)

Our circuit's input draws very little current, just for the opto-isolator LED. So it can be connected directly to the coil of this relay (the + side, of course!)

In order to set off the original alarm from our circuit, you'll need to connect the common of the unit's relay to ground and the make (or N/O) contact to a boot or bonnet microswitch. In this way, our circuit will simulate the opening of one or other of these elements by grounding the monitoring contact.

Standalone wiring

Here, the alarm will have to be armed using a concealed switch. For the alarm signal, we'll use a 12 V siren hidden within the engine compartment. The +12 V will go to the relay common contact and the make (N/O) contact will be connected to the siren, then the siren to ground (there are enough ways on the connecting terminal block to make these bridges internally).

We strongly recommend you do not use the car horn as the warning system by simply connecting it in parallel. If it is driven by a transistor in the car's electronics unit, this will be destroyed at the first alarm. What's more, any intruder won't necessarily be expecting there to be a second siren.

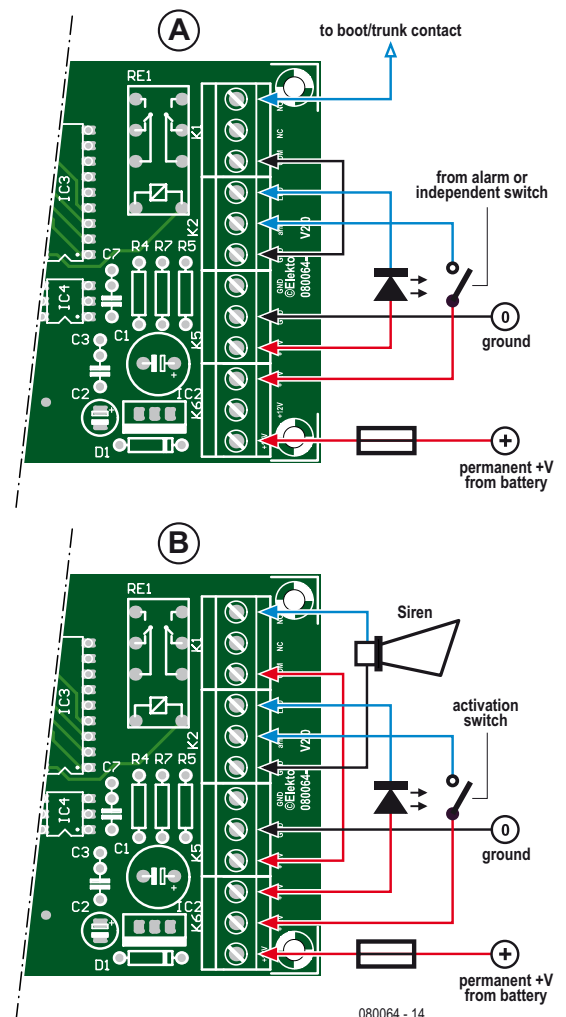

ble plastic conduit). Never allow any wire to be in contact with a metal part (bodywork, engine components, etc.), in case one day you end up with a short (or even a fire!) caused by the insulation wearing through because of the vibration when the car is being driven.

The alarm can be fitted anywhere, as long as it can be fixed in a horizontal position (see **Figure 3**). Provide a warning LED on the dash if you want to see if the circuit is armed or not. To adjust the level, proceed as follows:

- Park the vehicle in a spot where it is level;
- Cut the power to the alarm (remove the fuse from its holder);
- Set switch S1 3-6 (installation aid) to ON;
- Power the circuit back up again (refit the fuse);
- Tilt the alarm very gently in both axes until the X and Y LEDs both come on, indicating that it is horizontal. This adjustment is very sensitive and can be quite tricky to get just right. It doesn't matter if you can't manage it, as the alarm will still work in relative mode, i.e. it will be triggered according to the current angle of the car. But properly

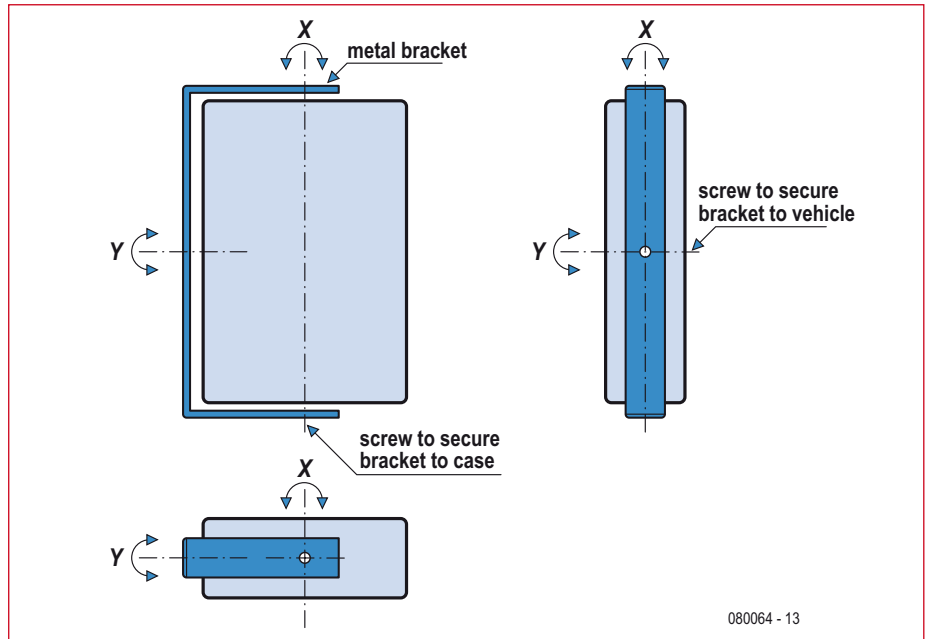

Figure 3. One option for mechanically mounting the alarm horizontally.

horizontal installation offers the best performance in all situations;

- Tighten the fixing screws firmly, using shakeproof washers, Nylock® nuts, or thread locking compound to avoid loosening over time caused by vibration.
- Cut the power;
- Set S1 3-6 back to OFF;

- Apply power to the alarm again, and it's ready for use!

(080064-1)

Internet Links

- [1] www.analog.com/en/mems-and-sensors/imems-accelerometers/adxl322/products/product.html
- [2] www.mikroe.com
- [3] www.elektor-usa.com/080064

COMPONENT LIST

Resistors

- R1 = SIL array 8x 4.7kΩ
- R2,R3,R4 = 1kΩ
- R5 = 330Ω
- R6 = 4.7kΩ
- R7 = 10kΩ

Capacitors

- C1 = 470μF 25V axial electrolytic
- C2 = 100μF 25V axial electrolytic
- C3, C6 = 100nF
- C4, C5 = 15pF ceramic

Semiconductors

- IC1 = PIC16F877-20/P, programmed
- IC2 = 7805
- IC3 = ULN2803A
- IC4 = 4N25 or equivalent
- D1 = 1N4001
- D2-D9, D12-D15 = 1N4148
- D10, D11 = LED, 3mm

Miscellaneous

- X1 = 8MHz quartz crystal, low profile
- JP1-JP4, JP5-JP8, JP9-JP12 : 8-way (2x4) DIL pinheader with jumpers

S1 = 4-way DIP switch block
 RE1 = relay, 12V coil, miniature, 2RT
 K1,K2,K5,K6 = 3-way SIL pinheader, lead pitch 2.54mm (0.1")
 Support for on/off LED, color and diameter to personal requirements

2-axis accelerometer module with ADXL322 (Lextronic France # ADXL322)
 Fuse and in-line fuseholder for vehicles
 Standoffs, screws, case, etc.

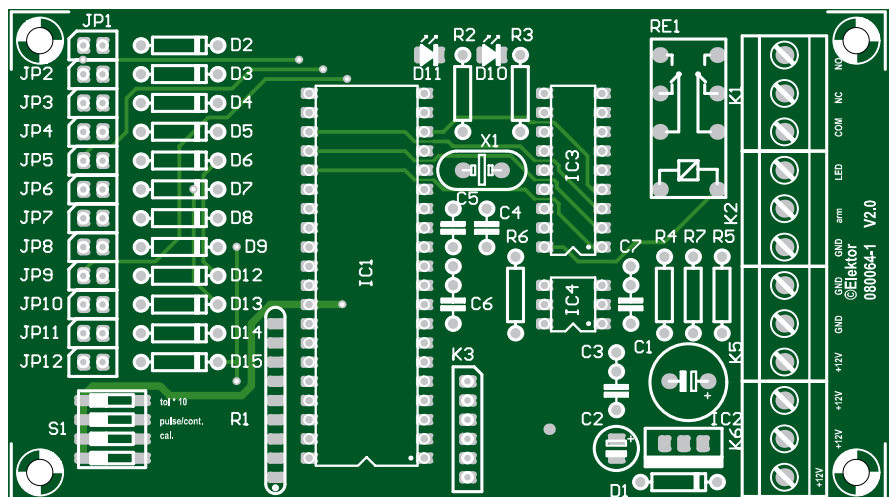

Don't just test it...
...Analyse it!

PEAK
electronic design ltd

Special Offer prices for limited period or while stocks last!

The New Atlas ESR Plus, Model ESR70



This new model of the famous *Atlas ESR* offers all the great features of the ESR60 but with extended measurement range and audible alerts.

This is the Atlas ESR Plus!

- Capacitance from 1uF to 22,000uF.
- ESR from 0.01 ohms to 40 ohms.
- Great for ESR and low resistance measurements (short tracing etc).
- Automatic controlled discharge.
- Audible Alerts (for good ESR, poor ESR, open circuit and more).
- Gold plated croc clips.

Atlas SCR - Model SCR100

Connect Triacs or Thyristors any way round.
Auto part+pinout identification
Check gate 100uA to 100mA.
Measures gate voltage drop.
Regulated load test conditions



Atlas IT - Model UTP05

Special Offer!
Identify network cabling type.
Identify many fault types.
Tests sockets and cables.
Complete with all this:



Atlas ESR - Model ESR60

Special Offer!
Capacitance and ESR!
Capacitance 1uF to 22,000uF
ESR 0.01ohms to 20 ohms
Gold plated croc clips



Atlas DCA - Model DCA55

The famous Peak Atlas!
Now with premium probes.
Connect any way round to
identify semiconductor type,
pinout and lots of parameters.



Atlas LCR - Model LCR40

Passive component analyser.
Identify inductors, capacitors
and resistors. Auto frequency
selection. Removable probes.



Atlas Star Pack (LCR/DCA)

Money Saving Pack! Save £20!
Includes the Atlas LCR,
Atlas DCA and a premium
padded carry case.
with extra spare battery.



Peak Electronic Design Ltd, West Road House, West Road, Buxton, Derbyshire, SK17 6HF.
tel. 01298 70012 www.peakelec.co.uk sales@peakelec.co.uk UK: Please add £2.00 p&p per order. Prices include UK VAT. See website for overseas prices.

e weekly

elektor newsletter

Take out a free subscription to E-weekly now

Do you want to stay up to date with electronics and computer technology? Always looking for useful hints, tips and interesting offers? Subscribe now to E-weekly, the free Elektor Newsletter.

Your benefits:

- The latest news on electronics in your own mailbox each Friday
- Free access to the News Archive on the Elektor website
- You're authorized to post replies and new topics in our forum



Register today on www.elektor.com/newsletter

ElektorWheelie

Elektor's DIY self-balancing vehicle

Everyone agrees; the internal combustion engine is coming to the end of its life cycle. However you don't need to go to the expense of a Prius or Tesla to experience the future of transportation devices. If you would prefer something more personal (and don't mind turning a few heads) why not build the astonishing ElektorWheelie? First take two electric motors, two rechargeable batteries and two sensors, now add two microcontrollers and the ElektorWheelie is ready to transport you in style to your destination.

Demo video on
www.elektor.com/wheelie

Characteristics

- Two 500 W DC drive motors
- Two 12 V lead-acid AGM batteries, 9 Ah
- Two sixteen-inch wheels with pneumatic tyres
- H-bridge PWM motor control up to 25 A
- Automatic power off on dismount
- Maximum speed approx. 11 mph (18 km/h)
- Range approximately 5 miles (8 km)
- Weight approximately 35 kg

The kit comprises two 500-watt DC drive motors, two 12-V lead-acid AGM batteries, two 16-inch ABS wheels, casing, control lever and assembled and tested control board with sensor board fitted on top.

Art.# 090248-71 • £1380.00 • € 1599.00 • US \$2275.00*

*Incl. VAT, excl. shipping costs.

Elektor
Regus Brentford
1000 Great West Road
Brentford TW8 9HH
United Kingdom
Tel. +44 20 8261 4509



Further information and ordering at www.elektor.com/wheelie

Portable solar battery chargers

By Thijs Beckers (Elektor Netherlands Editorial)

For the solar panel test, which was published in the July 2009 issue, we also asked for a number of smaller solar panels. These small panels are invariably intended to be used as battery chargers when on the road. However, at that time they had to give way to the large number of more interesting and bigger panels. We nevertheless were still keen to take a closer look at these mini panels. Elektor Lab worker designer Ton Giesberts carried out an evaluation of these panels. The charging current was measured using the supplied batteries. When no batteries were supplied we used our own. Here are the results!

The **Ansmann Energy Solar Charger** does not supply any voltage unless the batteries are connected. The charging current can easily reach 92 mA, charging two cells at the same time. This does require sufficient sunlight of course (which is also true for the other chargers). The charger is fitted with an indicator LED, a clip which functions both as a belt clip as well as a stand for fixed mounting and a USB connection for charging devices using a USB cable. The latter is also possible when there is no light on the panel. With a set of fully charged batteries the charger can therefore also be used for charging a USB device that is suitable for this. Various adaptor plugs for mobile phones and USB are supplied. Two 1300 mAh NiMH-batteries are also supplied, which can be charged simultaneously.

The (unbranded) **ES904** supplies and open circuit voltage of 6.1 V. The measured charging current amounts to about 93 mA. The charger is suitable for three AA batteries. Also supplied are an adaptor cable with a multiplug, two clips for attaching to a belt and a stand for optimal positioning when placed in a fixed location. The battery holder is separate from the charger.

The **PowerFilm AA Foldable Solar Charger** does not supply any voltage when no batteries are connected. The charging current amounts to a respectable 440 mA, which can be used to charge two or four AA cells. Two indicator LEDs are built in. Unfortunately there are no adaptor plugs and no USB connection option.

Compared to the other panels the **SolarDuo** from **Solarfocus** was somewhat less sensitive to its orientation towards the sun. The measured charging current was 293 mA (420 mA according to the specifications). The charger does not supply any voltage when no batteries are connected; it is provided with an indicator LED and a USB connection and comes with a variety of adaptor plugs and a cable. It is suitable for two AA cells, which are also supplied in the form of two 2300 mAh NiMH batteries.

The **SolarFocus SolarUno** supplied a charging current of only 160 mA (the specification is 420 mA). This charger does not supply an output voltage either when there are no batteries in the holder and therefore cannot be used as a standalone power supply. The charger is fitted with an indicator LED, a belt clip and a USB connection. The latter can also charge USB devices from the batteries without (sun) light. The charger can charge one or two AAA cells simultaneously. Two 700 mAh AAA NiMH batteries are supplied. Unfortunately there are no adaptor cable or plugs to be found anywhere in the packaging.

The tests were carried out on a very sunny day, outdoors, at Elektor House in Limbricht, the Netherlands. It is of course very conceivable that the chargers will perform differently when you take them on your sun-seeking holiday or on a trip to the Antarctic. The biggest difference however is still the total surface area of the solar cells. In this respect: the bigger, the better.

(090605-1)



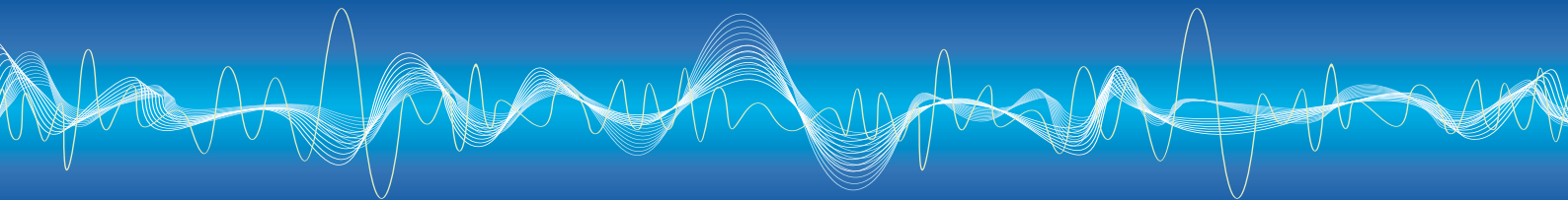

“Noise is **not cool**”

By Ton Giesberts (Elektor Labs)

For the last few years we haven't worried too much about noise in audio any more. In the past, and we mean the pre-CD era, the noise from a cassette player, record player or an FM radio was something we had to learn to live with. You had HiFi and all was well. Now that nearly everything is digital, even the picture and sound on the TV, it appears that noise for most audio designs is no longer a problem. Is noise out of fashion?

In other areas of electronics noise will continue to be a design consideration. Take the accurate conversion of a sensor signal which still requires analogue amplification, conversion and filtering, before it can be digitised.

With microphone signals, hum, noise and other interference signals are the criteria that will receive the most attention in studios or live performances. Once the recording is in a digital format the greatest problems are overcome. The problem of noise is then moved to sample frequency, the number of bits, digital operations and mixing.

With the arrival of the CD and the digital age the problems have become more complex and are harder to understand. For example, take the perennial discussion as to whether an LP sounds more faithful than a CD. The specifications of the noise in an analogue system are more informative to most people than the specifications of a digital linear phase filter. The noise of the latter is generally so low that most people will have difficulty comprehending it. The dynamic range of most modern codecs is greater than that of human hearing. Reproducing the sound pressure of a Saturn rocket at take-off (about 195 dB) is not required in our living room.

You would think that the boundary of what is necessary and useful has now been reached. In Elektor magazine, audio circuits have acquired a different position in recent years. The world of electronics these days revolves around microprocessors, FPGAs and so forth. With the exception of the revival of the LP and of valve amplifiers there seems to be little merit to be had from the familiar discrete stereo power- and pre-amplifiers from the good old days. Surround sound systems cost almost nothing nowadays and have more bells and whistles than you could ever need. In addition, most people are happy listening through cheap headphones (at levels that are much too loud) to the heavily compromised MP3 files.

But nevertheless there appears to be a revival of the ordinary stereo and so the story of noise reappears.

Noise of the oldies..

The vintage Elektor projects where a special effort was made to control the noise were mainly high end MD and MC amplifiers for record players. We also published discrete radio receivers where the noise characteristics are very important. But here too there are changes happening. Recently we published a small FM receiver (Mini FM receiver, January 2009) where the entire receiver is integrated into a single IC. With RF designs it is sometimes difficult to justify a discrete design, certainly since everything can be made so small now. The advantage of a discrete design is that there is no

need to compromise on any part of the circuit — at most the total cost will be more of a determinant of the final design. An example of the latter is the MC amplifier from March 1992. Here a dual PNP transistor was used for the input stage (lower LF noise than a NPN version) to obtain as low an input noise as was possible. We now use an ordinary opamp for that (for example the TL071). To avoid any other compromises, the small capacitors that were used for the correction network were not standard polyester devices but expensive 'styroflex' types with polystyrene as the dielectric. For the larger values 'MKP' types with a polypropylene dielectric were used. The larger value polystyrene capacitors were also made by Siemens, but production has been stopped since.

Or take the symmetrical microphone amplifier from November 1997. For optimal quality the phantom voltage has to be free of ripple and the amplifier has to have low noise. At the heart of the circuit was a symmetrical audio amplifier in an 8-pin DIP package from Analog Devices (there are now pin-compatible successors such as the SSM2019 and INA217). With 1 nV/√Hz input noise (at 1000×) this is difficult to equal with a discrete design taking up the same amount of space. In the meantime even better versions have appeared. In the datasheet for the SSM2019 you can find a nice application where the noise of the microphone amplifier is calculated based on the individual noise sources: source impedance of the microphone, current noise and voltage noise of the inputs. The influence of the current noise is frequently overlooked, because it is not often found in the datasheets. Because the individual noise sources are not correlated they cannot be simply summed together but you need to take the square root of the sum of the squares. If you would like to know more about different types of noise we can recommend the article by Hameg at www.hameg.com: “What is noise?”.

The real work

From the well-known formula for noise $\sqrt{4kTBR}$ — Boltzmann's constant, temperature in Kelvin, bandwidth and the resistance — the noise of a resistor can be calculated. You can use this, for example, to determine how low the noise of an opamp needs to be so that the effect on the signal processing is minimal compared to the impedance of the network around the opamp. And the other way around as well, of course. Once we have selected a certain application for an opamp then we can calculate the equivalent resistance of, for example, the feedback network so that it contributes to the noise as little as possible. The noise voltage is normally expressed at a bandwidth of 1 Hz. At T = 290 K noise is then equal to

$$\sqrt{(4 \times 1.38 \times 10^{-23} \times 290 \times 1 \times R)} = 127 \times 10^{-12} \times \sqrt{R} \text{ (per } \sqrt{\text{Hz}}\text{)}$$

So a resistance of 10 kΩ theoretically produces a noise voltage of nearly 13 nV/√Hz. If we take the entire audio bandwidth then the total noise voltage becomes 1.8 μV! Depending on the output current capability of an opamp and the signal level, the resistor values in a design cannot be smaller than a certain value. Whether

The influence of current noise is frequently forgotten and is often not even shown in the datasheet.

an expensive low-noise opamp will make a difference is then easily calculated. Other specifications can be more important, such as bandwidth, slew rate or distortion. We can also quickly calculate the effect of a resistor or network on the signal-to-noise ratio of a circuit: the noise of a resistor at a temperature of 290 K and a bandwidth of 20 kHz is then $18 \text{ nV} \times \sqrt{R}$.

If we wanted to design a microphone amplifier with a signal-to-noise ratio of 100 dB (with respect to 2 mV, B = 20 kHz), the total input noise would have to be less than 20 nV. This corresponds to the noise of a resistor of 1.2 Ω . In practice 20 dB less of signal-to-noise ratio will be more realistic (resistance of 120 Ω). The source impedance of the microphone is often the limiting factor.

(090560-1)

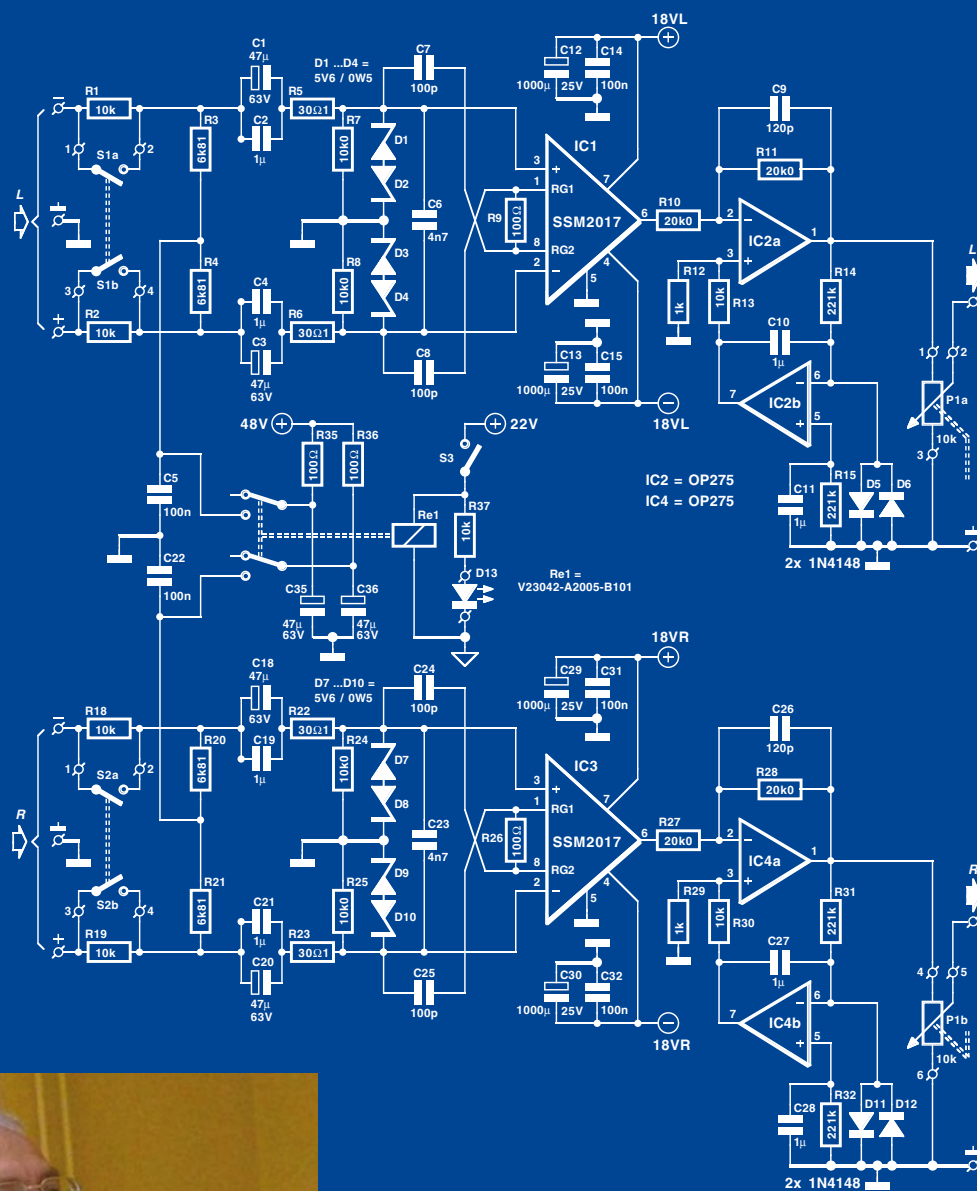

Ton Giesberts studied Electrotechnical Engineering at Heerlen Polytechnic in the Netherlands and has worked in the Elektor Labs since 1987. As a designer and a technical editor Ton's mainstay is the analogue project area. Ton's help is also called for occasionally when there's a niggling problem to solve with an RF circuit ...

Review: PSoC kit with RF module

By Luc Lemmens (Elektor Labs)

This kit, made by Cypress, has been designed so that users can easily become familiar with the flexibility and 'mixed signal' capabilities of their Programmable System-on-chip (PSoC) devices. On the accompanying CD, in addition to the development and programming software, are a sufficient number of ready-to-go examples so that you can quickly discover all the things that you can do with these processors. These contain programmable analogue and digital blocks that you can use to read sensors (such as thermistors, LDRs, etc.) and can drive actuators (such as LEDs, relays). In addition there are the usual serial interfaces such as SPI and I2C. The PSoC designer integrated development environment (IDE) gives the user the option of developing both code-level (chip dependent) as well as graphical (chip independent) applications. The Cypress 2.4 GHz CyFi technology offers the option of easily adding energy-efficient, wireless connections to embedded designs.

The kit contains everything to get started right away. To begin with, it contains a programmer that can program all the processors in the kit. This also functions as a bridge between other boards in the kit and a PC, via a USB-I2C interface. The kit also contains a low-power CyFi transceiver and when this is combined with a PSoC it can operate as a hub in a wireless CyFi network.

A second board, the so-called RF Expansion Card, contains a PSoC and a CyFi transceiver and it can also be a node in a CyFi wireless network. It can be used to measure temperatures using the thermistor mounted on the board. Using a connector, this board can also be attached to other systems and allow them to be wirelessly connected. A second connector makes an I2C interface and a couple of unused I/O lines from the processors available, which can be used to connect your own prototypes.

In addition there is the MultiFunction Expansion Card which — as the name suggests — implements multiple functions. It contains a CapSense slide controller (7 positions), a CapSense proximity sensor, a thermistor, a light sensor, a 3-colour LED and a miniature loudspeaker. This board does also have a connector with I2C interface and unused I/O lines. There are plenty of options for experimenting with the various sensors and actuators.

And finally, the development kit contains two boards which are intended as the battery power supplies for the last two boards mentioned.

This all invites you to get started with experimenting right away, but in practice it's not that easy. Firstly, the installation of the software, drivers and examples is rather vague. Absolutely irritating is the number of times you have to click OK while you have no other option, windows which obscure other windows, to put it briefly: this could have been done better. But this is not the end of the grief. If you think that after the installation you can immediately start with the supplied examples you're mistaken. The manual every now and then skips essential steps, or indicates the wrong directory where certain files should be found. When starting the programming software for the first time, the progress window shows only one line, so that essential messages are outside the field of view (such as which type of PSoC you should have selected).

But once you have overcome all these problems you will quickly become enthusiastic about these parts. These are fantastic processors and in combination with the CyFi technology offer countless possibilities for experimenting and to develop your own applications!

www.cypress.com/cyfi



The Cypress CY3271 PSoC® FirstTouch™ Starter Kit with CyFi™ low-power RF is available from several distributors for around 100 euros / 80 pounds / US\$ 125 (ex. taxes).

01279

**Credit Card
Sales**

467799

Motor Drivers/Controllers

Here are just a few of our controller and driver modules for AC, DC, Unipolar/Bipolar stepper motors and servo motors. See website for full range and details.

Computer Controlled / Standalone Unipolar Stepper Motor Driver

Drives any 5-35Vdc 5, 6 or 8-lead unipolar stepper motor rated up to 6 Amps. Provides speed and direction control. Operates in stand-alone or PC-controlled mode for CNC use. Connect up to six 3179 driver boards to a single parallel port. Board supply: 9Vdc. PCB: 80x50mm. Kit Order Code: 3179KT - **£15.95**
Assembled Order Code: AS3179 - **£22.95**



Computer Controlled Bi-Polar Stepper Motor Driver

Drive any 5-50Vdc, 5 Amp bi-polar stepper motor using externally supplied 5V levels for STEP and DIRECTION control. Opto-isolated inputs make it ideal for CNC applications using a PC running suitable software. Board supply: 8-30Vdc. PCB: 75x85mm. Kit Order Code: 3158KT - **£23.95**
Assembled Order Code: AS3158 - **£33.95**



Bi-Directional DC Motor Controller (v2)

Controls the speed of most common DC motors (rated up to 32Vdc, 10A) in both the forward and reverse direction. The range of control is from fully OFF to fully ON in both directions. The direction and speed are controlled using a single potentiometer. Screw terminal block for connections. Kit Order Code: 3166v2KT - **£22.95**
Assembled Order Code: AS3166v2 - **£32.95**



DC Motor Speed Controller (100V/7.5A)

Control the speed of almost any common DC motor rated up to 100V/7.5A. Pulse width modulation output for maximum motor torque at all speeds. Supply: 5-15Vdc. Box supplied. Dimensions (mm): 60Wx100Lx60H. Kit Order Code: 3067KT - **£17.95**
Assembled Order Code: AS3067 - **£24.95**



Most items are available in kit form (KT suffix) or assembled and ready for use (AS prefix).

Controllers & Loggers

Here are just a few of the controller and data acquisition and control units we have. See website for full details. Suitable PSU for all units: Order Code PSU445 £7.95

8-Ch Serial Isolated I/O Relay Module

Computer controlled 8-channel relay board. 5A mains rated relay outputs. 4 isolated digital inputs. Useful in a variety of control and sensing applications. Controlled via serial port for programming (using our new Windows interface, terminal emulator or batch files). Includes plastic case 130x100x30mm. Power Supply: 12Vdc/500mA. Kit Order Code: 3108KT - **£64.95**
Assembled Order Code: AS3108 - **£79.95**



Computer Temperature Data Logger

4-channel temperature logger for serial port. °C or °F. Continuously logs up to 4 separate sensors located 200m+ from board. Wide range of free software applications for storing/using data. PCB just 45x45mm. Powered by PC. Includes one DS1820 sensor. Kit Order Code: 3145KT - **£19.95**
Assembled Order Code: AS3145 - **£26.95**
Additional DS1820 Sensors - **£3.95 each**



Rolling Code 4-Channel UHF Remote

State-of-the-Art. High security. 4 channels. Momentary or latching relay output. Range up to 40m. Up to 15 Tx's can be learnt by one Rx (kit includes one Tx but more available separately). 4 indicator LED's. Rx: PCB 77x85mm, 12Vdc/6mA (standby). Two and Ten channel versions also available. Kit Order Code: 3180KT - **£49.95**
Assembled Order Code: AS3180 - **£59.95**



DTMF Telephone Relay Switcher

Call your phone number using a DTMF phone from anywhere in the world and remotely turn on/off any of the 4 relays as desired. User settable Security Password, Anti-Tamper, Rings to Answer, Auto Hang-up and Lockout. Includes plastic case. Not BT approved. 130x110x30mm. Power: 12Vdc. Kit Order Code: 3140KT - **£74.95**
Assembled Order Code: AS3140 - **£89.95**



Infrared RC Relay Board

Individually control 12 on-board relays with included infrared remote control unit. Toggle or momentary. 15m+ range. 112x122mm. Supply: 12Vdc/0.5A
Kit Order Code: 3142KT - **£59.95**
Assembled Order Code: AS3142 - **£69.95**



New! 4-Channel Serial Port Temperature Monitor & Controller Relay Board

4 channel computer serial port temperature monitor and relay controller with four inputs for Dallas DS18B20 or DS18B20 digital thermometer sensors (£3.95 each). Four 5A rated relay channels provide output control. Relays are independent of sensor channels, allowing flexibility to setup the linkage in any way you choose. Commands for reading temperature and relay control sent via the RS232 interface using simple text strings. Control using a simple terminal / comms program (Windows HyperTerminal) or our free Windows application software. Kit Order Code: 3190KT - **£69.95**

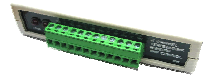

PIC & ATMEL Programmers

We have a wide range of low cost PIC and ATMEL Programmers. Complete range and documentation available from our web site.

Programmer Accessories:

40-pin Wide ZIF socket (ZIF40W) **£14.95**
18Vdc Power supply (PSU120) **£19.95**
Leads: Serial (LDC441) **£3.95** / USB (LDC644) **£2.95**

USB & Serial Port PIC Programmer

USB/Serial connection. Header cable for ICSP. Free Windows XP software. Wide range of supported PICs - see website for complete listing. ZIF Socket/USB lead not included. Supply: 16-18Vdc. Kit Order Code: 3149EKT - **£49.95**
Assembled Order Code: AS3149E - **£59.95**

USB 'All-Flash' PIC Programmer

USB PIC programmer for all 'Flash' devices. No external power supply making it truly portable. Supplied with box and Windows Software. ZIF Socket and USB lead not included. Assembled Order Code: AS3128 - **£49.95**



See website for full range of PIC & ATMEL Programmers and development tools.

Hearing Threshold Tester for PC

How good are your ears?

By Jan Breemer (The Netherlands)

These days nearly everybody has a portable music player (iPod, mp3 player, etc.).

But very few people realise how much these devices can affect our hearing. The hearing threshold tester presented here has been designed to check the state your ears are in.

The hardware and software presented here is meant to be used to easily test your hearing. It is possible to determine your hearing threshold and you can perform an A-B-X test [1] to see what differences there are in sound quality between, for example, an MP3 file and a WAV file. With future enhancements of the software (which you could easily write yourself) you can carry out a number of other tests and gain a better understanding how your ears work and what you can and cannot hear. The procedure for measuring your hearing threshold is actually very simple:

The system produces pure tones at various frequencies (generated by the PC or laptop) and with various amplitudes (determined by the attenuator box); an LED is used to indicate that a tone is being played and that you can use the push buttons to tell whether you heard the sound or not. In this way you can find out what the quietest sound is that you can just about hear. The results are shown in a graph and the whole process can be stored in a log file.

In the program you can specify the lowest and highest test frequencies

as well as the number of spot frequencies in between. The frequency scale is logarithmic.

Calibration

To make somewhat accurate measurements you need to carry out two calibrations. The first is to find out the relationship between the digital values sent to the sound card and the voltage of its output signal. The second is to determine the sensitivity of the headphones used.

There is an automatic procedure for the

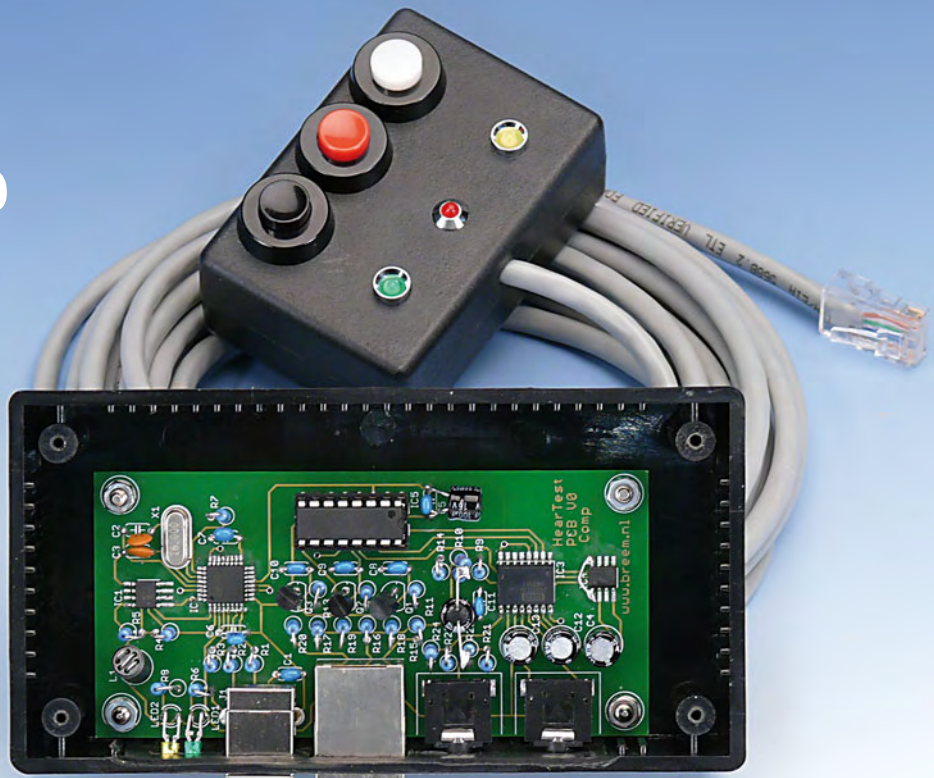

The circuit described here is for educational use only as it gives only gives rough results. If you suspect that you have any hearing problems you should always consult your GP and/or an audiology specialist.

About your hearing

When measuring sounds and how our ears react to them, two of the most important factors are the Sound Pressure Level (SPL) and the Loudness. SPL is an objective physical quantity that indicates what acoustic power density is associated with certain sounds. It is usually

(the Sone is a somewhat older, non-logarithmic unit). For example, to perceive a loudness of 40 Phon at 1 kHz you need a sound pressure of 40 dB. However, at 20 Hz you would need more than 90 dB to perceive the same loudness.

When hearing problems are diagnosed, a lot of attention is paid to

Pressure (Pascal)	Speed (m/s)	Intensity (W/m ²)	SPL (dB)	Notes
200	5×10^{-1}	100	140	rifle shot at 1 m, above the threshold of pain
20	5×10^{-2}	1	120	possible hearing damage during brief exposure
2	5×10^{-3}	10^{-2}	100	electric drill at 1 m distance
2×10^{-1}	5×10^{-4}	10^{-4}	80	motorway at 10 m distance
2×10^{-2}	5×10^{-5}	10^{-6}	60	TV at 1 m distance
2×10^{-3}	5×10^{-6}	10^{-8}	40	normal conversation at 1 m distance
2×10^{-4}	5×10^{-7}	10^{-10}	20	a quiet room
2×10^{-5}	5×10^{-8}	10^{-12}	0	human hearing threshold

given in dB where 0 dB corresponds to a sound pressure of 20 micro-Pascal. This is just about the quietest sound that can be perceived by human hearing at 2–4 kHz. (1 Pascal = 1 Newton/m²).

The relationship between the SPL and the actual sound pressure in Pascal is exponential. There is also another factor involved, which is the speed at which the air particles move due to the differences in pressure. The acoustic power density is the product of this pressure and this speed. The speed is directly proportional to the actual sound pressure, because the relationship between them, the acoustic impedance, is constant for air at atmospheric pressure. Sound pressure, speed and SPL are always given as RMS values.

The table shows how the units relate to each other.

Loudness is a subjective measure of the sound intensity, which depends very much on the frequency of the sound. The relationship between the SPL and the loudness as a function of frequency for human hearing is given by the Fletcher-Munson graphs (see Figure). These graphs have been compiled using measurements on a very large number of test subjects. These graphs show that when the frequency moves away from 1 kHz the subjective perception deviates significantly. The sensitivity deteriorates quickly at lower frequencies, and even more so at lower sound levels.

The bottom line of the Fletcher-Munson curves corresponds to the hearing threshold. This is the lowest sound level that can just be heard in extremely quiet surroundings. The wavy lines show the sound pressure (SPL) required to obtain a certain loudness in Phons or Sones

the hearing threshold. An increase at certain frequencies is an indication of some measure of hearing loss. Audiologists will pay particular attention to hearing loss within the frequency band that is important for the understanding of speech, since that has the most far-reaching social consequences. The frequency range for this is about 200 to 8000 Hz.

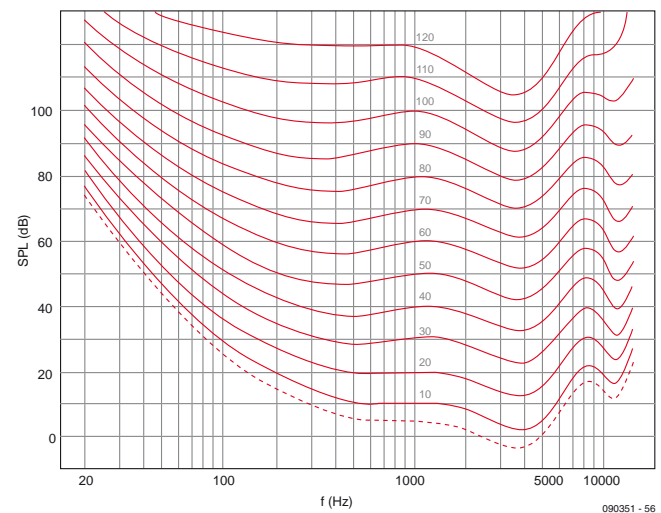

first. The microprocessor in the attenuator box has an on-board A/D converter that can be used to measure the input signal. The software has a calibration procedure that determines the relation between the digital values and the output voltage. During this procedure the sound card produces a 3 kHz tone at a certain amplitude for 1 s. The peak-to-peak value is measured by the A/D converter. With this value the program works out how to make the sound card generate a signal of $1 V_{RMS}$. The calibration for the sensitivity of the headphones is more complicated. There are a few ways of doing this:

- The program has the facility to use the details from the frequency response in dB/V for the calibration.

- When only the sensitivity in dB/mW is available, you will have to trust that the frequency response of the headphones is fairly flat. When you use this value you will also need the impedance of the headphones (for the calculations, see [2]). When you use figures in dB/V the impedance isn't required.

How does it work?

In this design the tones are produced by the sound hardware inside the PC or laptop. Two further requirements are a pair of headphones and a quiet room. The attenuator box is the only item that you have to build yourself for this project.

The attenuator unit is a straightforward circuit (see **Figure 1**). The

actual attenuation is carried out by a PGA2311 made by Texas Instruments. This is driven by a Freescale microprocessor of the same type as described in the SpYder project in Elektor March 2007. An FT232 chip is used to interface the circuit with the PC. The supply is taken from the USB connection. As an aside: an attenuator unit was used in this circuit because it has more flexibility and a greater range. Also, when you're carrying out A-B-X tests with music samples it becomes impractical to control the volume accurately, especially if you want to introduce differences to the left/right channels. And controlling all those different sound cards directly via their drivers wouldn't be practical either.

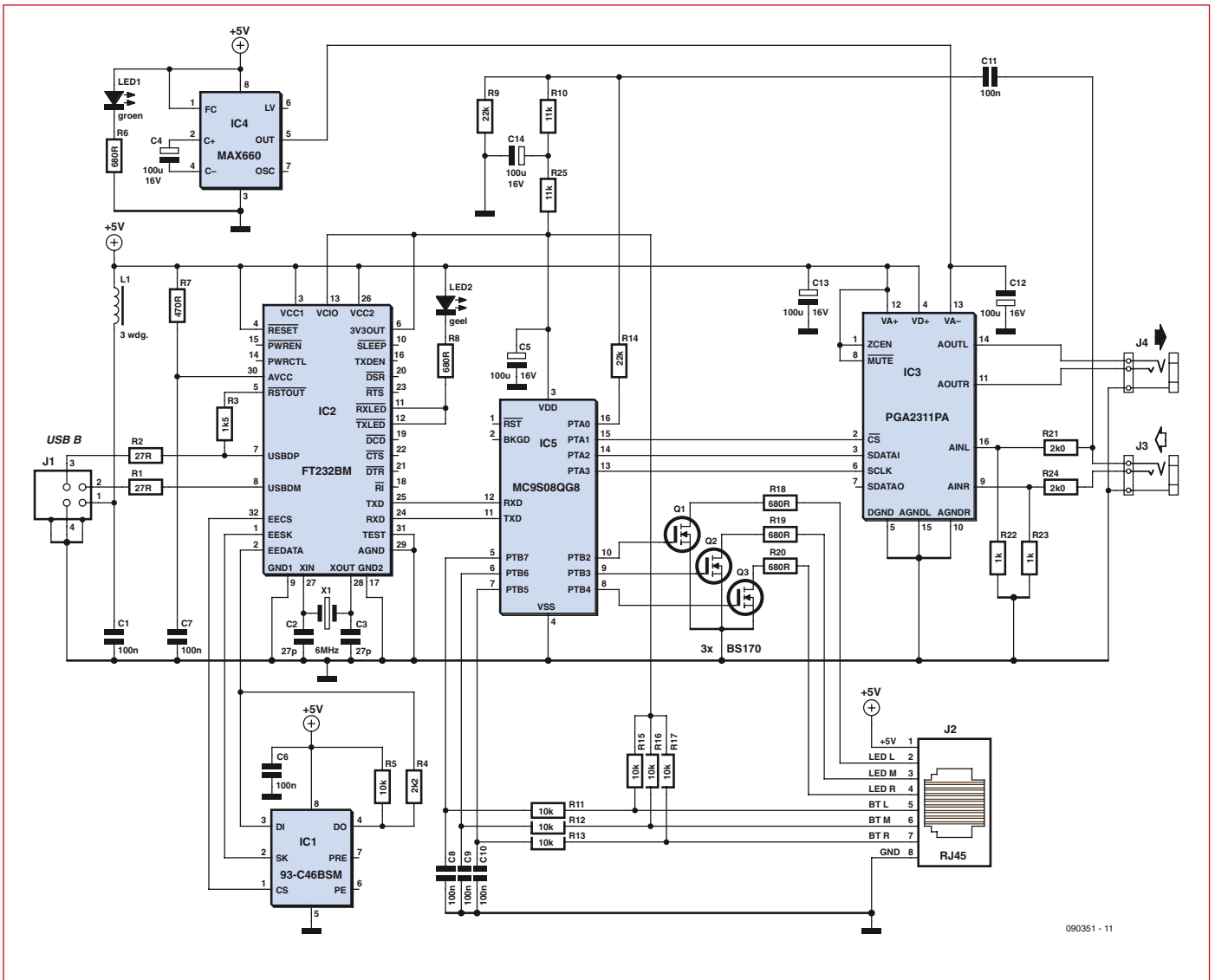

Figure 1. In the circuit diagram we recognise a few 'old favourites': the processor from the SpYder kit, an FT232 USB to serial converter and the PGA2311 that was previously used in the April 2004 High End Preamp.

Circuit Diagram

At the centre of the circuit is the microcontroller, which is responsible for controlling IC3, the communications with the PC/laptop via IC2, driving the LEDs and monitoring the push buttons. The original audio signal is fed to an analogue input of the microprocessor via C11 (necessary for the calibration). The DC offset of this input is kept at half the 3.3 V supply voltage by resistors R9 and R10/R25. Series resistor R14 prevents the IC input from being overdriven when the input signal exceeds 3.3 V_{pp}. At the right of the controller we find the audio signal attenuator, IC3. It has a range from -95.5 dB to +31.5 dB, in steps of 0.5 dB. The input signal has already been attenuated by 10 dB (by R21 to R24), so the effective range starts at -105 dB (and ends at

+21.5 dB). IC2 takes care of the USB communications. This is a USB to serial converter. Using a suitable driver, the PC program can communicate with the attenuator as if it was on a serial port. The VID, PID and USB configuration are stored in a small EEPROM chip, IC1. R1 and R2 provide the correct impedance for the USB signal connection. R3 is a pull-up that signals to the USB host what type of USB device is connected (here it is version 2.0, full speed). R4 and R5 are pull-ups for the bi-directional data connection to the EEPROM. The LEDs in the switch box are driven by three MOSFETs, T1 to T3. The exact type isn't that important. The current through the LEDs is determined by R18 to R20. Try to use LEDs with a higher efficiency and increase the values of the resistors accordingly. We can only

take a maximum of 100 mA from the USB connection. The push button signals are fed to the microcontroller via filters (R11 to R13/C8 to C10). R15 to R17 are used as pull-ups. The negative supply voltage required by IC3 is generated by IC4. A number of decoupling capacitors have also been added. L1 C1, C6 and C13 form a filter to keep interference outside and/or inside. D1 shows when the supply voltage is present, while D2 lights up when communications with the PC take place. The construction isn't very difficult. Most of the components used are through-hole types. Start with the smallest components, in this case the SMD ICs and finish with the largest. The trickiest will be IC2. A good technique is to place a blob of solder on the

solder pads, solder the IC and remove any excess solder using a desoldering braid.

The PCB layout (which can be downloaded from [3]) has been designed such that all components are on one side. This makes it easy to mount the board into a box. If you are absolutely certain that the distance between your PC or laptop and the quiet room will never need more than 5 m of USB cable, you can mount the LEDs and push buttons into the same box. In that case the RJ45 connector is no longer needed. If you need more than 5 m you'll have to mount the LEDs and push buttons into a separate box, which is then connected to the attenuator box using Cat5 cable and an RJ45-8 plug. As with the headphone cable, this cable can be several tens of metres long without any problems.

Software and hardware

Apart from the serial communications, the firmware for the HCS09 microcontroller also takes care of the LEDs and the scanning of the push buttons. The programming of the controller is made easy when you use the USB SpYder stick and its development software [4].

The PC software, which can be downloaded from [3], does not have to be installed. Extract the files onto your computer and place them in a suitable folder, such as C:\Program Files\HearingTest\. You do need to have the Visual Basic 6 Run-time environment installed (can be downloaded from [5]). The hearing threshold tester makes use of a virtual COM port via USB. To make this work, you'll need to have a driver installed on the PC for a virtual USB COM port. The driver found at [6] has been fully tested by the author and works well.

In theory any sound card should be suitable. Connect the attenuator unit to the line output or the headphone socket. Don't use an output meant to drive loudspeakers. You should also turn off any special effect on the sound card. This means no (pseudo) multi-



Figure 2. The attenuator unit. From left to right: the yellow LED indicates when communication with the PC takes place, the green LED shows when the supply voltage is present. Next to that is the USB connector, the RJ45 connector for the push button box, the signal input and finally the connector for the headphones.

channel, bass boost, echo or reverb effects, etc. The volume should be at its maximum setting. Turn off any other programs that (may) use the sound card.

The ideal headphone is a closed one that fits completely over your ears.

Unfortunately, good-quality closed headphones are mainly made for the professional market and have a price tag to match. Low impedance headphones (<300 Ohm) aren't preferred for this project.

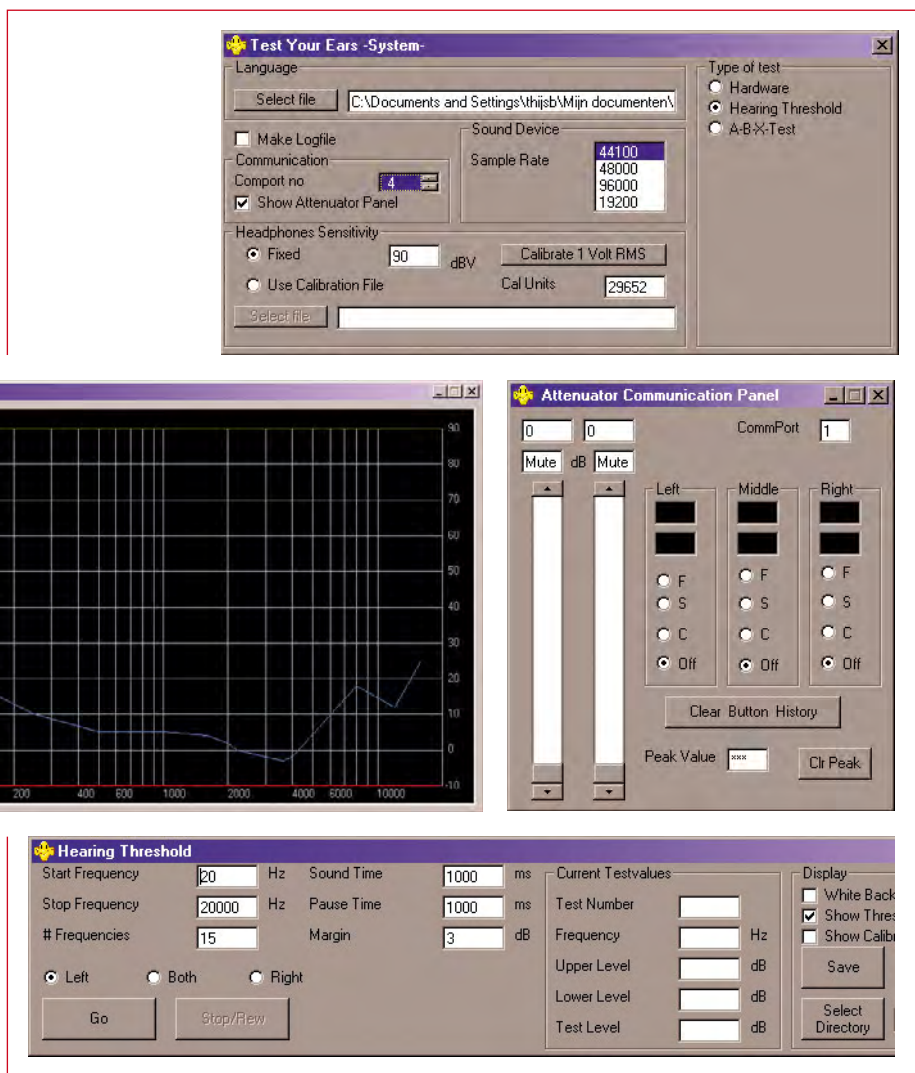

Figure 3. The program displays a main window ('System') and a number of sub-windows depending on the type of test.

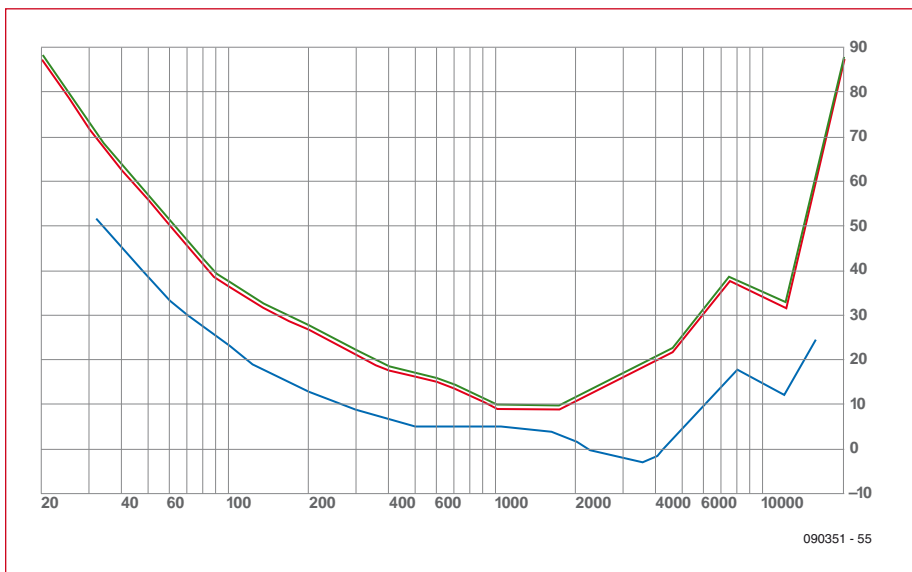

Figure 4. The result gives a clear overview of the hearing threshold. The blue line is the normal hearing threshold for young, healthy ears, measured in a perfectly quiet room.

Operation

We'll start with a hearing threshold test. Connect the attenuator unit to the PC with a USB cable and connect the audio input to the line-out of the sound card (see **Figure 2**). If all is well, the computer will find a USB Serial Port. Take a look via the Device Manager (in WinXP: *Start -> Control Panel -> System -> Hardware tab -> Device Manager*) which COM port number has been assigned to the unit. Now start the program (TestYourEars.exe) and select your required language (see **Figure 3**). From the main window, enter the correct COM port number and tick the box if you'd like to see the attenuation panel in the future. Usually this isn't required. Indicate whether you want to use a single, fixed number for the calibration of the headphones, or if you have a calibration file. Next let the program calibrate a $1V_{RMS}$ signal. In the box 'Calibrate $1V_{RMS}$ ' you can see the peak value required to output a $1V_{RMS}$ from the sound card. You should expect a figure somewhere between about 10000 and 32000.

Now choose the hearing threshold test. If needed, change any settings in the hearing threshold window and click on *Begin* to start the test. Next, take the switch box to an extremely quiet area (a large wardrobe full of clothes works well) and put on the headphones. The (middle) red LED lights up whenever a tone is reproduced via the headphones. If you weren't sure if you heard it, or were disturbed by another noise, you can press the middle button to repeat

the same tone at the same loudness. The left and right LEDs indicate that you should press one of the appropriate buttons. The left button is used to tell the system that you heard the tone. If you didn't hear the tone you should press the right button. The same tone will then be played again, but louder if you didn't hear the previous one, or softer if you did hear it. Once the difference in loudness has become less than the setting in 'Margin', the same procedure will be followed with the next higher frequency.

In this way the system interactively determines the lowest level at which you can hear a frequency and then moves on to the next frequency. The results are shown immediately on a graph on the screen.

Once the test has completed the red LED flashes quickly and the results can be inspected on the screen. The green line represents the lowest level that could still be heard and the red line is the highest level that could no longer be heard.

The results can be saved as a bitmap or as a comma-separated-variables text-file. In the 'Display' section you can change a few things regarding the graph. A white background is usually much better when you want to print the graph. 'Show Threshold' displays the standard hearing threshold for people. 'Show Calibration' displays the calibration curve for the headphones, if it's used.

Enhancements

Enhancements for this program seem to present themselves naturally. In the first instance you can determine the hearing threshold as a function of frequency. This is the most important criterion if you are looking for hearing loss as a result of nights out in the disco or the use of portable music players. This hardware offers many more possibilities though.

With additions to the software you can investigate masking effects, for example:

- Pure harmonics; what percentage harmonic distortion can you detect?
- Nearby frequencies; how weak should a tone that is close to another be before you can no longer hear it?
- Distant frequencies; how soft does a tone with a clearly different frequency have to be before it can no longer be heard?
- Noise; how loud should a tone be for it to be heard above white noise? The noise can also be narrowband, covering an octave or less. The tone can be inside or outside the noise band. All these tests can be carried out on one or two ears.

The hardware can also be used to carry out A-B-X tests on, for example, music samples. You could write a program that could add a certain amount of distortion to music samples and then test to see how much distortion can be noticed with which type of music. The interface details can be found on the author's website [2]. The PCB artwork files (Eagle format, including schematic) and the component list for this project may be found at [3].

(090351-1)

Internet Links

- [1] http://en.wikipedia.org/wiki/ABX_test
- [2] <http://www.breem.nl/TyE>
- [3] www.elektor.com/090351
- [4] www.elektor.com/shop, search for 'spyder' or '060296-91'
- [5] <http://support.microsoft.com/kb/290887>
- [6] <http://www.fidichip.com/Drivers/VCPh.htm>



PCBCORE

China PCB Supplier (Prototype thru Production)

- ✓ 1-layer up to 30-layer
- ✓ Cost and quality
- ✓ On time delivery
- ✓ Dedicated service
- ✓ Instant Online Quote & Order
..... Day and Night

**No minimum quantity – 1 piece is welcome
Check our low price and save big \$\$\$...**

86(571)86795686 sales@pcbcore.com
www.pcbcore.com



FRONT PANELS & HOUSINGS

Cost-effective single units and small production runs

Customized front panels can be designed effortlessly with the Front Panel Designer. The Front Panel Designer is available free on the Internet or on CD.

- automatic price calculation
- delivery in 5–8 days
- 24-Hour-Service if required



Sample price: 32,50 €
plus VAT/shipping

Schaeffer AG · Nahmitzer Damm 32 · D-12277 Berlin · Tel +49 (0)30 8 05 86 95-0
Fax +49 (0)30 8 05 86 95-33 · Web info@schaeffer-ag.de · www.schaeffer-ag.de



**We add value to PCBs
when others just sell it.**

- One Stop Manufacturing Service
- \$10 ea. for 5pcs 4"x4" 2L
- Free Solder Mask & Silkscreen
- Free Components
- Free Assembly



Assembly Components Pcb's
Enclosures Fpcs Keypads



Designing Service

3D Enclosure Designing Virtual Assembly PCB Design



www.EzPCB.com

Email: sales@ezpcb.com

Please Visit www.machinepier.com For Machining

Pocket Preamp

Part 2: a simple preamplifier with tone control

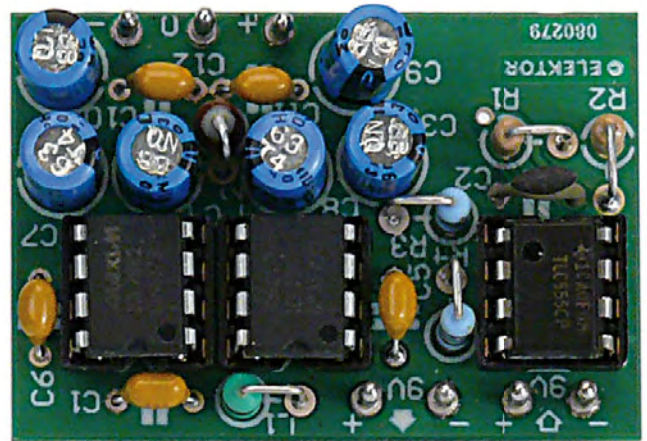
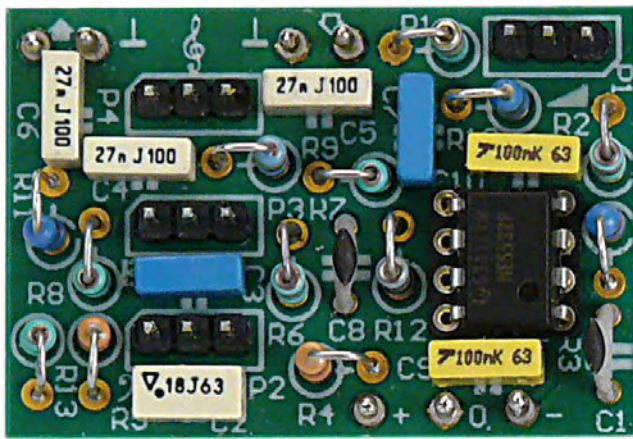

By Ton Giesberts (Elektor Labs)

The PWM power stage discussed in the previous instalment (June 2009) can be used perfectly well on its own. But a matching preamplifier with power supply would complete this amplifier nicely. That is why this month's Mini Project presents the sequel: the Pocket Preamp.

In the June 2009 instalment of this series of articles we described a small PWM amplifier. What is missing from this are tone and volume controls. Since most people are spoilt these days with surround sound systems equipped with an equalizer as an absolute minimum, we made this preamp with a 3-way tone control, instead of the more customary bass/treble control.

Tone control

The tone control has an adjustment range of ± 12 dB for the low and high frequencies and ± 9 dB for the mid frequencies. The latter is more than enough, because our ears are more sensitive to mid-range frequencies. The circuit will also remain reasonably straightforward with these values. If these adjustment ranges are too small then there is very likely something wrong with the loudspeakers.

Main Specifications

- 3-band tone control
- Symmetrical supply
- Compact
- Connector layout matched to associated boards

A control range of 12 dB means that, because of the relatively limited power of the output stage, there is an imminent danger of overdriving it, particularly for the low and middle frequencies. After all, an increase of 12 dB implies an increase in power by a factor of 16!

The circuit

The volume control (P1) is connected directly to the input of the preamplifier

(see **Figure 1**). This is the best place to prevent the tone control stage from being overdriven. The first amplifier stage (IC1a) is non-inverting and has a gain of 4 times as calculated from

$$R3 / R2 + 1$$

At a supply voltage of ± 9 V, a signal of more than 1 V (i.e. a little over $1.2 V_{eff}$) can be processed without distortion, when the tone controls are in their centre positions. It will be obvious that when either the high or the low tone control is at its maximum value, the maximum permissible input signal is a lot smaller at only 300 mV (for the applicable frequencies, of course). At this point the output of the tone control is just below the point of being overdriven (but it will already overdrive the power amp, so take care!).

The operation of the tone controller is not all difficult to understand. The part

around IC1b is an inverting amplifier with three feedback circuits connected in parallel for the tone control. Resistor R12 ensures that the output cannot swing to the power supply rail in the event of contact bounce by the wiper of P2. Incidentally, R1 functions in a similar way for volume control P1. C8 and C1 suppress RF (high frequency) interference.

P2 is the bass control. C2 determines the frequency range that will be controlled. Simply put, at higher frequencies, C2 effectively shorts out P2. The amplification is then determined by the ratio of R5 and R4. The ratios of P2 to R4 and R5 determine the minimum and maximum control range respectively. The maximum gain for example is

$$(P2+R5) / R4$$

and amounts to about 5.5 times (15 dB, DC). R6 is necessary so that the other frequencies can be adjusted with P3 and P4. C7 primarily determines from which frequency the high tone control operates. C5 and C6 ensure that the tone control has a steeper response. Components R9 and C4 have the same functions for the mid frequency control as R6 and C7 for the low and high controls. C3 has the same function as C2, but filters the high frequencies much later. Together with C4 it sets the range of the mid control. In the end, the control ranges of the mid and high adjustments are not only determined by, for example, the ratio of P3 to R7 and R8, but the other components in the feedback circuit also play a role. That is why the ratios between P3 and P4 to R7/R8 and R10/R11 are greater than would be expected from the actual control ranges.

The low tone control has quite a wide bandwidth, because we assume that small loudspeakers will be used. If this tone control is going to be used with a larger amplifier and ditto speakers a larger value for C2 may result in a better sound. Output resistor R13 prevents problems in the event an excessive capacitive load is connected.

Power supply

The power supply is symmetrical. This way we can avoid relatively large coupling capacitors and their detrimental effects on sound quality. The disadvantage is that a negative supply voltage

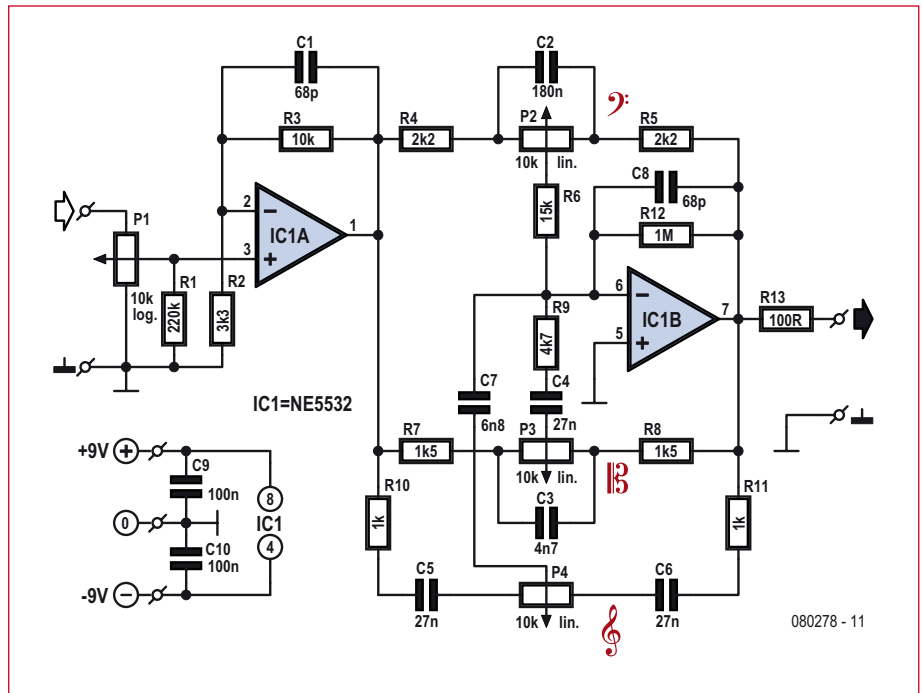

Figure 1. The preamplifier is quite straightforward for a volume control with triple-band tone control.

is required. The easiest solution is a circuit that inverts the positive power supply.

We selected a DC/DC converter from Maxim, the ICL7662 (see Figure 2). This IC works as a charge pump and can operate with voltages up to 20 V. Pin-wise and functionally the IC is compatible with the more common ICL7660, which can operate up to 10 V (the 'A' version can handle voltages up to 12 V). These parts can also be used here without any problems. The big-

gest advantage of this is the simplicity; only two external capacitors are required. A small disadvantage is that the output voltage is not regulated. The unloaded output voltage is equal to the input voltage, but negative. As the output current increases the output voltage will reduce however. To increase the stability of the output voltage two ICs are connected in parallel. If you load a single IC powered at 9 V with a resistance of 100 Ω, the output voltage drops to about -4.6 V. With two ICs in parallel this drops to only

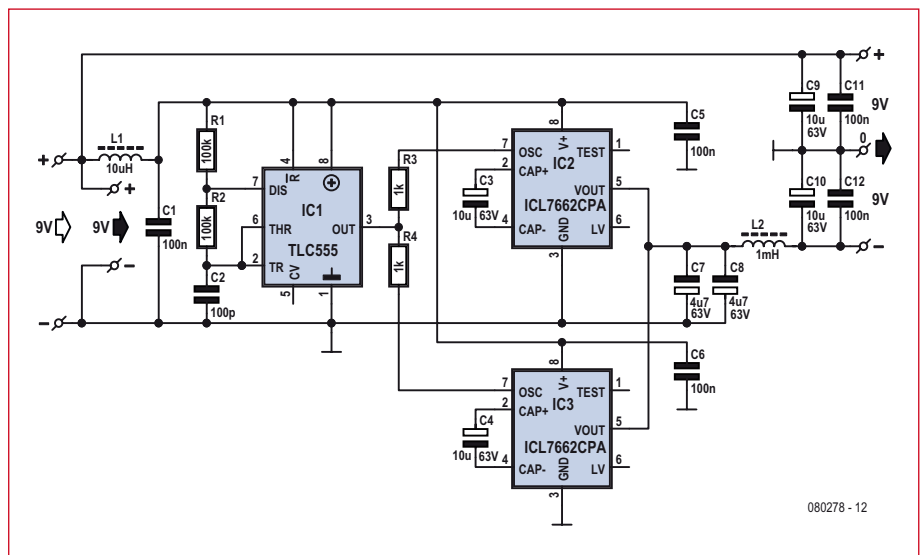
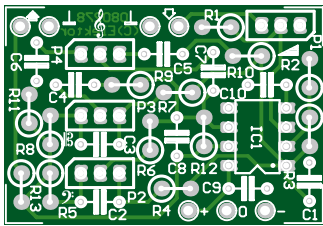

Figure 2. A voltage converter is used to convert a single power supply voltage into a symmetrical power supply.

COMPONENT LIST
Preamplifier board



Resistors

- R1 = 220kΩ
- R2 = 3.3kΩ
- R3 = 10kΩ
- R4,R5 = 2.2kΩ
- R6 = 15kΩ
- R7,R8 = 1.5kΩ
- R9 = 4.7kΩ
- R10,R11 = 1kΩ
- R12 = 1MΩ
- R13 = 100Ω
- P1 = 10kΩ potentiometer, logarithmic
- P2,P3,P4 = 10kΩ potentiometer, linear

Capacitors

- (lead pitch 5mm / 0.2")
- C1,C8 = 68pF ceramic
- C2 = 180nF polyester / MKT
- C3 = 4.7nF polyester / MKT
- C4,C5,C6 = 27nF polyester / MKT
- C7 = 6.8nF polyester / MKT
- C9,C10 = 100nF polyester / MKT

Semiconductors

- IC1 = NE5532 (DIP-8)

Miscellaneous

- PCB, # 080278-1, from www.thepcbshop.com

-6.3 V. With your preamplifier as a load the output voltage drops only 0.35 V (the NE5532 draws about 7.5 mA). You could also use other opamps that have a lower current consumption, but their quality is often inferior; the NE5532 is an excellent audio opamp. In our prototype we initially connected four ICs in parallel, but with three or four not much more is gained. There was however a strange effect: the ripple in

which results in a much smaller resistance loss for this coil. The inductor we used for L2 has a rated series resistance of 12 Ω. L1 and L2 are standard axial noise suppression chokes, which are fitted upright here. The latter is also true for the four resistors in the circuit; this saves space.

We won't dwell on the circuit around the 555. It is the standard astable configuration. IC1 drives the clock

amount of the switching frequency of the power amplifier can be seen.

Test results

The most interesting test results for the tone controller are of course the individual frequency response curves for the tone adjustments. **Figure 3** shows the maximum, minimum and neutral positions (the positions of the bass and treble controls remain

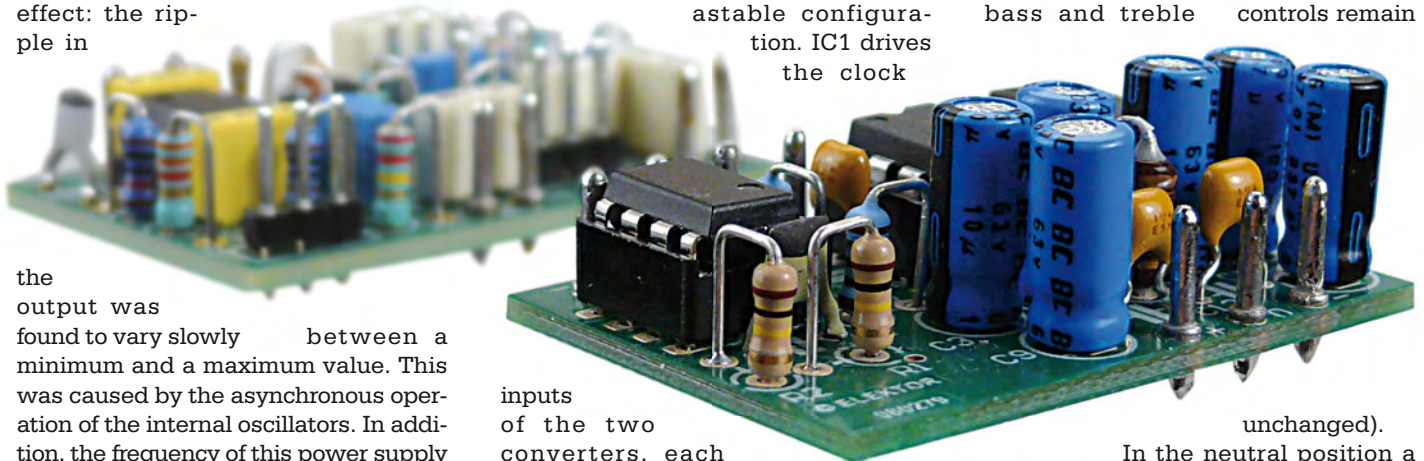

the output was found to vary slowly between a minimum and a maximum value. This was caused by the asynchronous operation of the internal oscillators. In addition, the frequency of this power supply ripple was 10 kHz so it could become audible. That's why the ICs are driven with an external clock furnished by a 555 IC. The frequency of the 555 is set to 40 kHz, so that the ripple at 20 kHz is just outside the audible range. An advantage is that the inductor in the output filter can be much smaller,

inputs of the two converters, each via a 1 kΩ resistor, to prevent potential problems at power-on (risk of latch-up). The ripple across the filter capacitors C7 and C8, which are connected in parallel for a lower series resistance, is almost completely removed by output filter L2/C10/C12. On an oscilloscope only a very small

unchanged). In the neutral position a slight attenuation of less than 1 dB at 20 kHz can be seen. This is mainly caused by RF suppression capacitors C1 and C8. At 20 Hz the variation in gain is ±14 dB (±12 dB at 40 Hz) and at 20 kHz it is about ±12 dB.

The distortion with an input signal

COMPONENT LIST
Power supply board

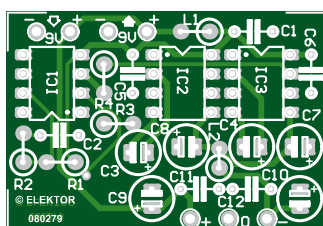

Resistors

- R1,R2 = 100kΩ
- R3,R4 = 1kΩ

Capacitors

- C1,C5,C6,C11,C12 = 100nF ceramic, lead pitch 5mm (0.2")
- C2 = 100pF, lead pitch 5mm (0.2")
- C3,C4,C9,C10 = 10μF 63V radial electrolytic, lead pitch 2.5mm (0.1")
- C7,C8 = 4.7μF 63V radial electrolytic, lead pitch 5mm (0.2")

Inductors

- L1 = 10μH axial (vertical mounting)
- L2 = 1mH axial (vertical mounting)

Semiconductors

- IC1 = TLC555 (DIP-8)
- IC2,IC3 = ICL7662CPA+ (DIP-8) (Maxim IC)

Miscellaneous

of 0.5 V is less than 0.005 % (1 kHz, 22 kHz bandwidth, volume control to maximum, tone controls to neutral). The current consumption of the entire circuit is 56 mA at 9 V, 12 mA up on the PWM amplifier by itself. With an 8 Ω loudspeaker and the amplifier overdriven slightly, the current consumption peaks at about 162 mA. This really is too much for a 9 V battery. With multiple channels we therefore recommend that you use an AC power adapter.

During the tests we didn't actually use potentiometers for the tone controls, but instead went for rotary switches and resistors. This is because the interest is mainly in the performance at the neutral positions and at the upper and lower limits. So,

Construction of the three boards

The connections for the three boards have been placed in the same positions as much as possible. The output of the preamplifier is in the same corner as the input to the power amplifier. The power supply connections of the preamplifier are in the same place as the power supply outputs of the power supply board. The 9-V input of the power supply board is looped directly to the two connections for the power amplifier. The position of these corresponds to the power supply connections of the power amplifier. On the power amplifier, next to the power supply connections, there are also the connections for the power supply switch (S1). This is only for the power

Kit set

As indicated in the parts list, you can order the bare printed circuit boards for this project from www.thepcbshop.com. However, a complete kit set is also offered in the Elektor web shop, which comprises the printed circuit boards and all necessary parts, see www.elektor.com/080278.

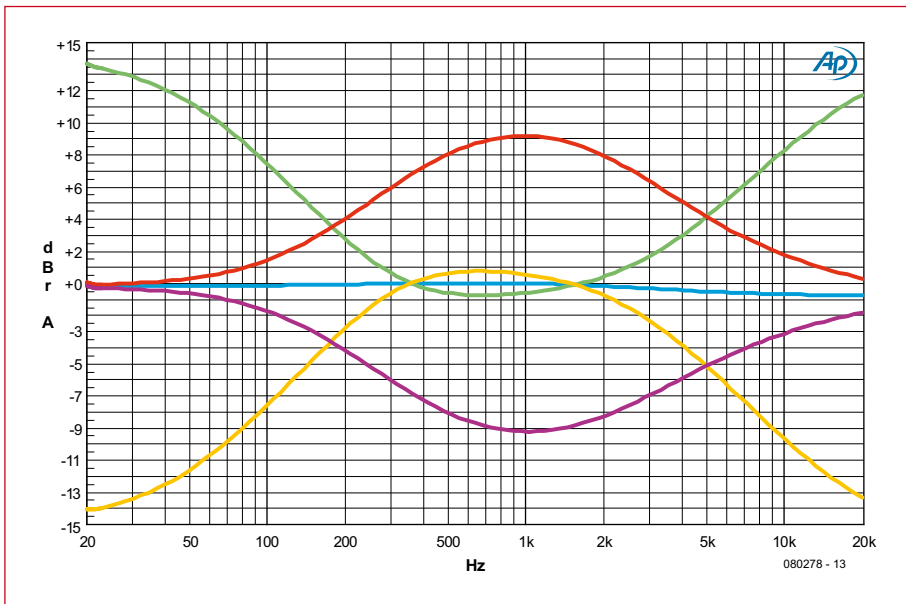
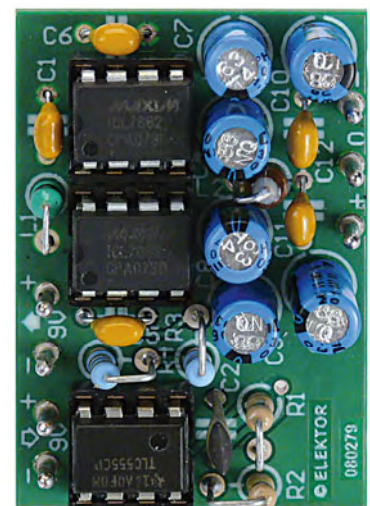
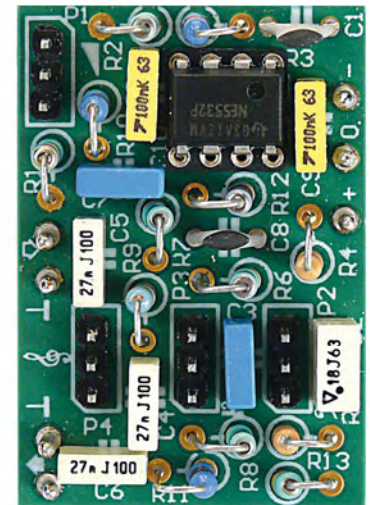
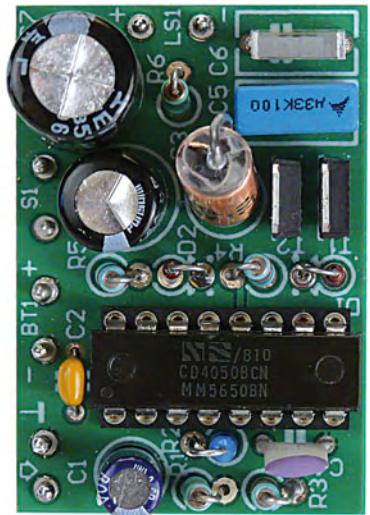

Figure 3. The curves show the effects of the different maximum settings of the tone control.

each potentiometer is reduced to two resistors and a rotary switch. The tolerance of pots is usually quite large; ±20 % is typical, and inevitably has an effect on the frequency ranges and maximum and minimum gains. With multiple channels the individual deviations can result in audible differences. If you have the opportunity to check whether the individual channels of stereo potentiometers are matched then it is certainly recommended that you do this. With more than two channels, the use of rotary switches with multiple poles may be considered, but this is an expensive solution.

amplifier. It is better to insert a switch in series with the input to the power supply board. You can then short out the connections for S1.

Mounting holes were deliberately not included on all three of the boards so that everything is as compact as possible. For a reliable mounting option you could consider a couple of plastic supports with slots. The boards can then be mounted one above the other. The best order is the power supply board at the bottom, the tone control above that and the power amplifier at the top.

(080278-1)



A performance test
of 10 noise cancelling
headphones

The Sound of Silence

By Harry Baggen (Elektor Netherlands Editorial)

Background noise can be very irritating while you are listening to music. Fortunately we can get round this these days by using headphones that reduce background noise using anti-sound. In this article we'll take a look at a number of these so-called noise cancelling headphones.

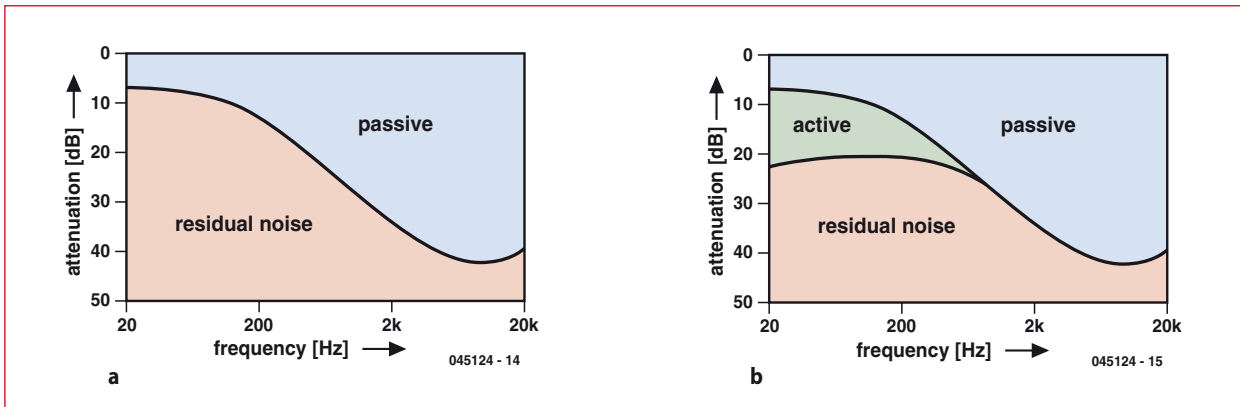

Figure 1. Diagram (a) shows the effect of the passive suppression caused by the earcups of the headphones. When an active NC system is added the lower frequencies are suppressed as well (b).

They're becoming more and more common: people on the street, bus, train and plane wearing headphones or earphones, enjoying their favourite music. Unfortunately, the 'enjoyment' has to be taken with a pinch of salt. If it's not the lack of quality of the headphones, then the background noise will introduce a measure of interference. Listening to music can be particularly relaxing when you're travelling for hours on the train or plane. But in these situations there will be a continuous rumble in the background, caused by the wheels on the rails or the jet engines of the plane. Fortunately we can do something about this with the help of so-called antisound, so you can relax in (artificially generated) peaceful surroundings and enjoy your music.

Theory

There are two ways in which unwanted sounds can be reduced. The first is really very simple: sealed headphones that have earcups covering the whole of the ears will passively reduce the noise. This type of ear-protection is used widely within the construction industry. However, they're usually not very comfortable. Furthermore, such passive systems predominately suppress middle and high frequencies, whereas train and plane noise is generally in the lower frequency band (Figure 1a).

In the second method electronics gives us a helping hand. The background noise is picked up using a microphone, amplified, shifted 180° out of phase and finally mixed with the music signal. In this way the interference signal is removed. Any changes in the background noise are immediately picked up and effectively suppressed. In Figure 2 you can see the principles involved.

Such an active system lends itself particularly well to the suppression of noise with lower frequencies. When this is combined with passive suppression it results in good suppression across the whole audio spectrum (Figure 1b).

Practice

Such noise cancelling headphones are made by many manufacturers. There are special types designed to be used by e.g. pilots, but these days there are also many headphones available for general music playback on the bus, train, plane, or even at home. It is the last category that we've explored in this article.

Noise cancelling headphones for general consumer use can be roughly divided into three groups.

There are purely passive types, where the mechanical construction of the earcups or earbuds provides a reduction of background noise. Examples of this are the SE420 and SE530 made by Shure. These are in-ear types, where the

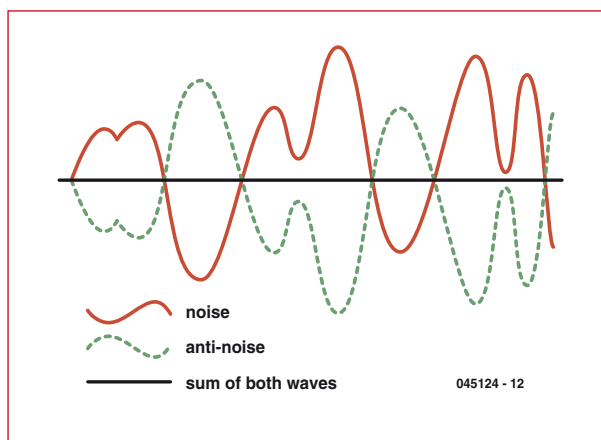

Figure 2. Removing noise: The interference is measured, its phase inverted and mixed with the original signal.

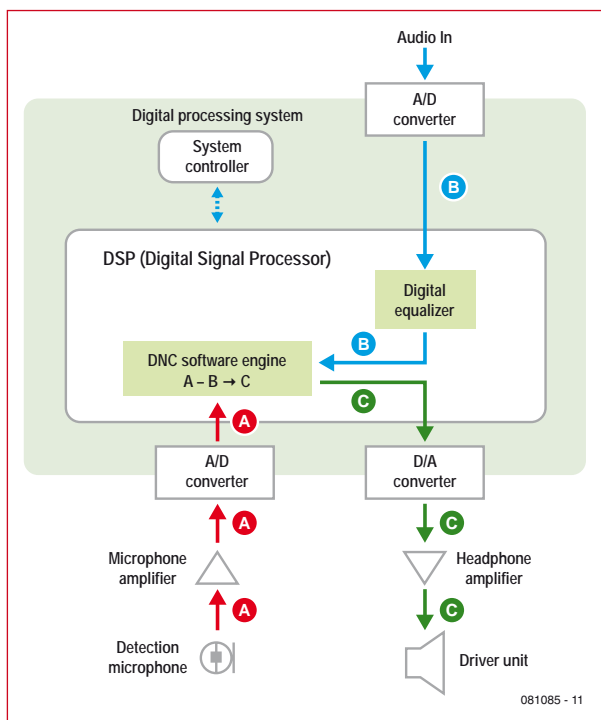

Figure 3. In a digital NC system a DSP removes the background noise.

earbud is pushed into the ear canal. Despite its passive construction there is a good amount of suppression.

With active noise cancelling (from now on abbreviated to NC in this article) headphones we can differentiate between analogue and digital types. With analogue types the inverted signal that's mixed with the original audio signal is generated by a microphone in conjunction with a small audio amplifier. This is the system that can be found in most NC headphones. The results can be quite good, but are dependent on the technical design of the control system.

With digital types (generally the more expensive ones) a DSP is used to intelligently remove interfering sounds. With these the microphone signal and the audio input are first digitised before being fed to a DSP, which compares them and performs some calculations on them. The resulting digital signal is then converted back into analogue and fed to the earcups via an amplifier. An example of this can be seen in **Figure 3**, which Sony uses in its more expensive models. In the most recent versions the composition of the background noise is analysed and the result is used by the DSP to choose a filter pattern that is most effective at removing the noise.

Effective?

For this article we've asked virtually all well-known manufacturers of headphones to supply us with several samples so we could get an impression of the effectiveness of the built-in suppression electronics and, of course, the eventual

sound quality of these headphones. The price range is from about £35 (€40) to £350 (€400), which leaves something for everybody. Most samples were supplied with a set of accessories, such as a travel case, cables and converter plugs, and in one case it included a charger for the built-in rechargeable batteries.

Since it would be very difficult to directly measure the effectiveness of these NC headphones (mainly due to the different types in our test set, like in-ear and sealed types), we decided to use subjective judgments for the effectiveness of the noise suppression and the sound quality.

The noise suppression is tested in several realistic environments, such as traffic noise, a server room with air conditioning, and in a noisy office. In other words, in places that most of us experience on a regular basis.

We also noted how comfortable they are to wear, which isn't an insignificant point when they're worn for hours on end.

On the basis of these criteria you should be able to pick your favourite, depending on what's most important to you.

Some other criteria that could affect your choice: How much are you prepared to pay for such NC headphones? How often would you use them and how important is the sound quality?

The ratings given to the products are on a scale of 10.

Prices approximate and subject to trade discounts.

Products tested may not be available in all countries.

Audio Technica ATH-ANC7

These on-ear headphones are finished to a high standard. They come with a strong travel case, plane adapter and a 6.3 mm in-line adapter. All plugs and adapters are gold-plated. The power is supplied by an AAA battery, which should last about 30 hours according to the manual. Plus point: The headphones also work when the battery is empty, although they sound a bit quieter.



The earcups are fairly small, so they rest on the ears. They don't exert that much pressure, so the comfort level with longer use is reasonable.

The sound quality of these AT headphones is quite good, with a balanced mid-range and high frequency response,

and a solid bass response. With the NC system turned on, there is a slight noise noticeable from one earcup, but this all but disappears when music is played. When the NC system is turned off the response becomes a bit flatter.

The active NC system suppresses low-frequency noises very well, and voices are barely noticeable in the background.

Sound quality: 7

Noise suppression: 8

Comfort level: 6

Retail price: approx. £175 (€200)

Bose QuietComfort 3

These are well-designed on-ear headphones. The earpads are a bit smaller than those of the AT, but they're very soft and hardly press on the ears. This makes the comfort level very good. A wide range of accessories is included, such as a plane adapter and 6.3 mm in-line adapter, an extension cable (nearly all plugs are gold-plated), a charge adapter for the two special batteries with several types of mains plug for world-wide use, and a sturdy travel case.

The QuietComfort 3 can only work with the NC system turned on, so always make sure that you take a spare, fully charged battery with you (a spare battery is included in the box of accessories). The noise generated by the electronics is barely noticeable.

The Bose has a very good sound quality with a well-defined mid-range, but a slightly limited top range and a very powerful bass, which could have been a bit quieter, although



you get used to this after listening for a while. The noise suppression is very good and particularly effective at lower frequencies. Voices come through a bit stronger than with the AT, but apart from that, all noise is suppressed very well.

Sound quality: 8
Noise suppression: 8
Comfort level: 7
Retail price: approx. £350 (€400)

JVC HA-NC250

These relatively small and lightweight on-ear headphones also come with a travel case, connection cable, and several gold-plated in-line adapters. The HA-NC250 needs a single AAA battery and also functions with the NC system turned off. The earcups are not very big and therefore rest on the ears. They exert very little pressure on the ears, so are hardly noticeable. When you move your head the earcups stay in place very well.

The HA-NC250 has an agreeable and somewhat neutral response with a good definition in the mid and high ranges. The bass response is perhaps not as powerful as with some other models, but still fits in well with the rest of the frequency response.



The noise suppression system works best at lower frequencies and functions quiet well. Voices are quite noticeable, but that is also due to the small earcups and the light pres-

sure on the ears, which results in less acoustic isolation.

Sound quality: 7
Noise suppression: 6
Comfort level: 7
Retail price: approx. £175 (€200)

JVC HA-NCX77

These in-ear headphones have earbuds with an angled section onto which the rubber end-plugs fit, making it easier to put them into the ear canal. The electronics have been put inside a separate little box, which also contains the energy source (one AAA battery). This box also has a volume control, an on/off switch for the NC system and a monitor switch to temporarily turn off the music when you suddenly want to talk to somebody. Everything can be stored in an accompanying case.

The sound quality of these earbuds is quite disappointing when compared with the on-ear types. The sound appears quite tight and there is only a limited bass response. We should point out that with earbuds the sound quality



depends very much on how they're placed in the ears and how well they fit, and this is something that can be different for different people.

The noise suppression of the HA-NCX77 is only moderate. This is also affected by how well the earbuds fit, and this too depends very much on the individual. This is also the reason why no scores have been given for the comfort level of earbuds. Some people don't have any problems with earbuds, whereas others can't seem to stand having them in their ears.

Sound quality: 5
Noise suppression: 4
Comfort level: not assessed
Retail price: approx. £70 (€80)

Philips SHN2500

The cheapest set of earbuds with an active NC system in this test is the SHN2500. This time there is no carry-case, but you do get two in-line adapters. The earbuds have the same shape and dimensions as most normal earbuds. As far as we can tell, the microphone has been placed at



the back. The NC electronics have been put in a simple external case, which also contains an AAA battery for the power. A slide-switch is used to turn the NC system on or off. With the NC system on there is some quiet background noise, although it isn't disturbing.

After choosing the right size of silicone end-plugs the earbuds fitted quite well in the tester's ears despite the straight shape, and also closed off the ear canal very well. The sound quality is quite acceptable, especially at this price. The mid-range seemed somewhat limited, which is something that many cheap in-ear headphones suffer from.

The noise suppression manages to reduce some of the low-frequency noise, but most of the suppression is a result of the acoustic isolation caused by the earbuds themselves. But this is certainly not a bad thing.

Sound quality: 6
Noise suppression: 5
Comfort level: not assessed
Retail price: approx. £35 (€40)

Philips SHN7500

These deluxe in-ear headphones made by Philips have earbuds that are somewhat more ergonomically shaped. The microphones on this model are found on the sides. The SHN7500 comes with a storage case, several adapters and of course three different sizes of silicone end-plugs (just like all other in-ear models in this test). The NC system has also been put in an external box here, and works off an AAA battery. It has a switch for the noise suppression system and a linear volume control. The travel of the latter is very short, making it difficult to find the right volume level. The cabling runs partially along a strap that's mounted to the box, so you can wear the box from your neck and there won't be any other trailing cables.

After picking the right size of silicone end-plugs the SHN7500 produces a surprisingly good sound that comes close to that from some larger on-ear headphones. A fairly balanced response and a strong bass response result in an enjoyable listening experience.



BEST BUY

The NC system manages to remove a fairly large amount of low-frequency noise from the signal, on top of the reduction caused by the acoustic isolation of the earbuds. This is quite a performance from a system costing £85!

Sound quality: 6.5
Noise suppression: 6
Comfort level: not assessed
Retail price: approx. £85 (€100)

Sennheiser PXC 300

These are light-weight on-ear headphones that can be folded into a fairly small package. A carry case, plane adapter and 6.3 mm in-line adapter are all included. The NC electronics are housed inside a tubular box that is powered by 2 AAA batteries. This box can be clipped onto a shirt or suit. The headphones also work when the NC system has been turned off.

The PXC300 fits well on the ears and exerts little pressure. Thanks to its light weight the earpads stay in place during head movements. Some noise can be heard when the NC system is turned on (the NoiseGard Advance system by Sennheiser). Music reproduction is clear with a little too much emphasis on the mid and high ranges. This makes the bass response seem a bit flat, but it is still well defined.



The noise suppression performs reasonably well. Although low-frequency noises are suppressed by the NoiseGard system, voices still come through due to the small (and somewhat loose) earcups.

The separate box housing the electronics isn't really convenient, but it does have the advantage that it keeps the headphones themselves very light.

Sound quality: 6
Noise suppression: 6
Comfort level: 8
Retail price: approx. £175 (€200)

Sennheiser PXC 450

These are large, sturdy on-ear headphones finished to a high standard, which use the digital NoiseGard 2 system

by Sennheiser. This luxurious system comes with a sturdy carry case, plane adapter and 6.3 mm in-line adapter. All plugs have been gold-plated. The PXC 450 needs a single AAA battery. The noise generated by the NC system is minimal. On the headphones are an on/off switch, a volume control with two push buttons and a talk-switch for when you need to talk to someone for a moment. There is also a bypass switch for when you want to use the headphones without the NC electronics.

The large earcups completely cover the ears and form a good seal. According to Sennheiser they can even be used as passive ear protectors when the cable is removed. The

earcups press somewhat hard against your head, and therefore aren't that comfortable if you wear the headphones for a long time.

The sound reproduction of this top-model is very balanced, with a tight and deep bass response, but it all sounds a bit too flat to really make the music come alive.

The (digital) NC system is extremely effective and manages to strongly suppress background noise, even at higher frequencies up to 1 kHz. Most of the other types have to rely on the passive suppression caused by the earcups at this frequency.

Sound quality: 8

Noise suppression: 9

Comfort level: 7

Retail price: approx. £300 (€350)



Shure SE530

The SE530 is the only passive NC headphone in this test. Shure doesn't actually use the term NC, but calls them 'Sound Isolating Earphones'. It was interesting to see how these passive headphones compare with the active versions.

The SE530 is the most expensive type from the SE series and is delivered in a deluxe case, which contains the earbuds (it almost sounds disrespectful at this price), a storage case, connecting cable with an in-line volume control, sev-

Advertisement

See your project in print! Elektor magazine is looking for Technical Authors/Design Engineers

If you have

- ✓ an innovative or original project you'd like to share with Elektor's 140 k+ readership and the electronics community
- ✓ above average skills in designing electronic circuits
- ✓ experience in writing electronics-related software
- ✓ basic skills in complementing your hardware or software with explanatory text
- ✓ a PC, email and Internet access for efficient communications with Elektor's centrally located team of editors and technicians

then don't hesitate to contact us for exciting opportunities to get your project or feature article published.

Our Author Guidelines are at: www.elektor.com/authors.

Elektor

Jan Buiting MA, Editor

Regus Brentford, 1000 Great West Road, Brentford TW8 9HH, United Kingdom

Email: editor@elektor.com





eral in-line adapters, eight sets of end-plugs and a special cleaning tool. The way these earbuds are worn differs from all the other types. The connecting cable points upwards, and this initially takes some getting used to.

It takes some time to pick out those end-plugs that fit, since a large number of them are included, but it is very important that you select the ones that fit well in your ears and hence seal them as well as possible.

Once you've succeeded, the SE530 produces a very good, neutral sound, which no other headphones in this test come close to. Voices sound as if they're next to you, the high frequency response is clear and very detailed, and the bass response is deep and powerful, without being overpowering. We couldn't give it full marks (i.e. 10/10), otherwise that wouldn't leave room for improvement.

As for the noise suppression, the SE530 doesn't score very high. Just like the other in-ear headphones, it provides reasonable suppression of the mid and high range, but for a good suppression of the lower frequencies an active system really is essential.

Sound quality: 9

Noise suppression: 4

Comfort level: not assessed

Retail price: approx. £435 (€500)

Sony MDR-NC500D

This highest priced on-ear-model made by Sony is made from magnesium and aluminium and uses a Li-ion battery for power. The well-designed headphones are delivered with a strong case, universal charger, connecting cables and several (gold-plated) plugs. There is even a separate battery holder that can be used when the internal battery runs out. This is just as well, since the headphones cannot be used without the NC system.

The MDR-NC500D uses a DSP for the noise suppression.



An automatic setup system analyses the background noise and uses the results to select the optimum frequency band for the suppression of noise. There is a button on the earcup that can be used to start this test again at any time.

The earcups are just a little bit too small to cover the ears completely, but with a bit of wriggling it could just be done. The headphones felt quite comfortable and hardly pressed against the head.

The sound quality of the MDR-NC500D is excellent. The reproduction is very balanced and gives a spacious feel. The quality of the bass response was only bettered by the Sennheiser PXC 450, but according to our ears, these are overall the best sounding headphones in this test.

The noise suppression system is very intelligent and figures out the best noise suppression to use in various situations, particularly with lower frequencies. Higher frequencies are suppressed somewhat less, possibly because the earpads aren't pressing that hard against the ears.

Sound quality: 9

Noise suppression: 9

Comfort level: 8

Retail price: approx. £350 (€400)

Conclusions

After listening to a number of these special NC headphones we can certainly conclude that most of them are effective, albeit at a cost. Nearly all of the headphones tested here cost £175 (€200) or more, due to the extra electronics. However, if you travel a lot by public transport or by air and want to enjoy your favourite music with the minimum of disturbance, it would be worthwhile to acquire some NC headphones.

When using these headphones the sound quality is just as important as the level of noise suppression. What's the point in having an effective noise cancelling system if the sound quality is abysmal? The comfort level plays a role too. We've also made an assessment on this, but it is something that is best judged by yourself before you buy a pair of headphones.

The on-ear types appeared to give the best results in this test, partially because their construction provides them with better acoustic isolation. Usually they also sound better than their in-ear compatriots, but it should be pointed out that three of the four in-ear types tested here are significantly cheaper than the others.

And the winner is... The best headphones appear to be the Sony MDR-NC500D. This is the only one that offers both an excellent sound quality and a very effective NC system. As far as the noise suppression is concerned, the Sennheiser PXC 450 was similar, but we weren't quite as impressed by its tonal qualities.

In the category '**Best price/quality ratio**' the Philips SHN7500 comes out ahead. It offers reasonable sound quality and quite effective noise suppression, as long as you don't mind wearing earbuds in your ears. At a cost of £85 (€100) Philips has placed a good product in the market.

All of the headphones covered should be available, or can be ordered, from audio/video stores as well as online retailers.

(090577-1)

Deep enough?



MemoryPrime 2MEGA
MEMORY BUILT-IN

NEW

Discover Deep Memory Performance.

Due to memory constraints, traditional digital storage oscilloscopes do not have the capability of displaying a complete electronic signal at a high sample rate. The GDS-1000A Series uses MemoryPrime technology to overcome the problems associated with memory constraints. By displaying complete signals with greater detail, the GDS-1000A Series can maintain a high sample rate over a wider horizontal range, without affecting performance. **Challenge yourself to go deeper, GDS-1000A !**

GDS-1000A Series Digital Storage Oscilloscope

- 150/100/60 MHz Bandwidth, 2 Input Channels
- Sample Rates up to 1GSa/s Real-Time Maximum, 25GSa/s Equivalent-Time
- 2M Points Record Length Maximum
- 2mV~10V Vertical Scale, 1ns~50s Horizontal Range
- Up to 27 Automatic Measurements
- USB and SD Interface Supported

For more information about the advantages of MemoryPrime technology, visit our website at www.memory-prime.com or consult your local distributor.

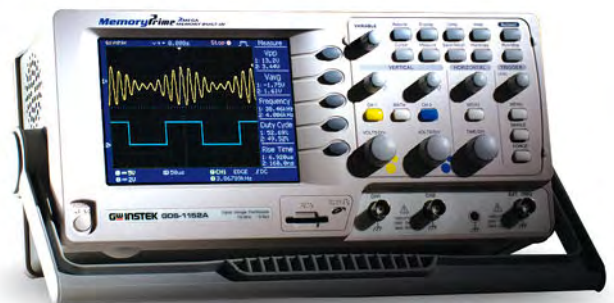

Buy GDS-Series get a limited lifetime warranty & a complimentary SD card reader !



GOOD WILL INSTRUMENT CO., LTD.
No. 7-1, Jhongsing Road, Tucheng City,
Taipei County 236, Taiwan
T +886-2-2268-0389 F +886-2-2268-0639
E-mail: marketing@goodwill.com.tw

GW INSTEK
Made to Measure Since 1975
www.gwinstek.com

Mini Preamplifier

Easy to operate thanks to
AVR micro & LCD



By Paul van der Vleuten (Belgium)

This small pre-amp has both a good sound quality and a simple and flexible control interface thanks to the use of an ATmega8 microcontroller. Two digital potentiometers are used to control the volume, and a two-line backlit LCD displays the volume and input source settings.

After listening to an expensive audio system a few times the author wanted to buy a pair of Dynaudio loudspeakers. However, they were quite expensive at the time. Thinking of the expression “the best things come to those who wait”, the author eventually managed to buy them at a discounted price. But a pair of speakers on their own doesn't make a good audio system; at the very least you'll need a good amplifier as well. Unfortunately, the budget was (almost) spent.

That left the DIY route. First the power amplifier had to be built. Since the lady of the house wanted everything as compact as possible, it would have to be based on an integrated power amplifier. The most important criteria that had to be met by the power ampli-

fier (apart from a good sound quality), were a robust protection against a DC offset at the outputs and absolutely no clicks or pops should be heard when it was turned on or off. In the end the author chose an LM4780 made by National Semiconductor in combination with an NTE7100 (μ PC1237) protection IC. The latter provides a switch-on delay, the detection of any DC offset at the output and it also turns off the speakers when the mains voltage is present at the transformer side. Along with the protection circuits inside the LM4780, this pair makes a well-protected power amplifier that can be built in a very compact form.

But this isn't what this article is about. In it we'll concentrate how to select the input source and the volume con-

trol that precedes such an amplifier. In other words: a preamp. And this has to be compact as well, of course!

So what's the most important component in a preamp — obviously the potentiometer! But what type should be used, a normal one or some exotic, expensive version? The latter was rejected due to the abovementioned criteria and an ordinary potentiometer would not satisfy the quality requirements. After some research it was decided to use a digital potentiometer, the AD5290 made by Analog Devices. This device has 256 steps, which is sufficient for a volume control. And a THD of only 0.006% isn't bad either. Fine, but it's the symmetrical supply voltage of ± 4.5 to ± 15 V that makes this device attractive as allows the AD5290 to be

easily added to opamp circuits using symmetrical power supplies. The digital potentiometer is controlled via a 3-wire SPI. When a byte is clocked in (MSB first), the 'wiper' of the AD5290 is set to the corresponding position. The AD5290 used here is a 100 kΩ type. With this value no switching clicks could be heard.

Controlling this potentiometer is quite straightforward with the help of an AVR micro and Bascom. The author chose an ATmega8 as the microcontroller. And since we're working with a microcontroller we may as well add some bells and whistles, such as:

- Input selection using relays.
- Volume control using a rotary encoder.
- Display the name of the input source on the LCD.
- Select the names for the input source from a predefined list.

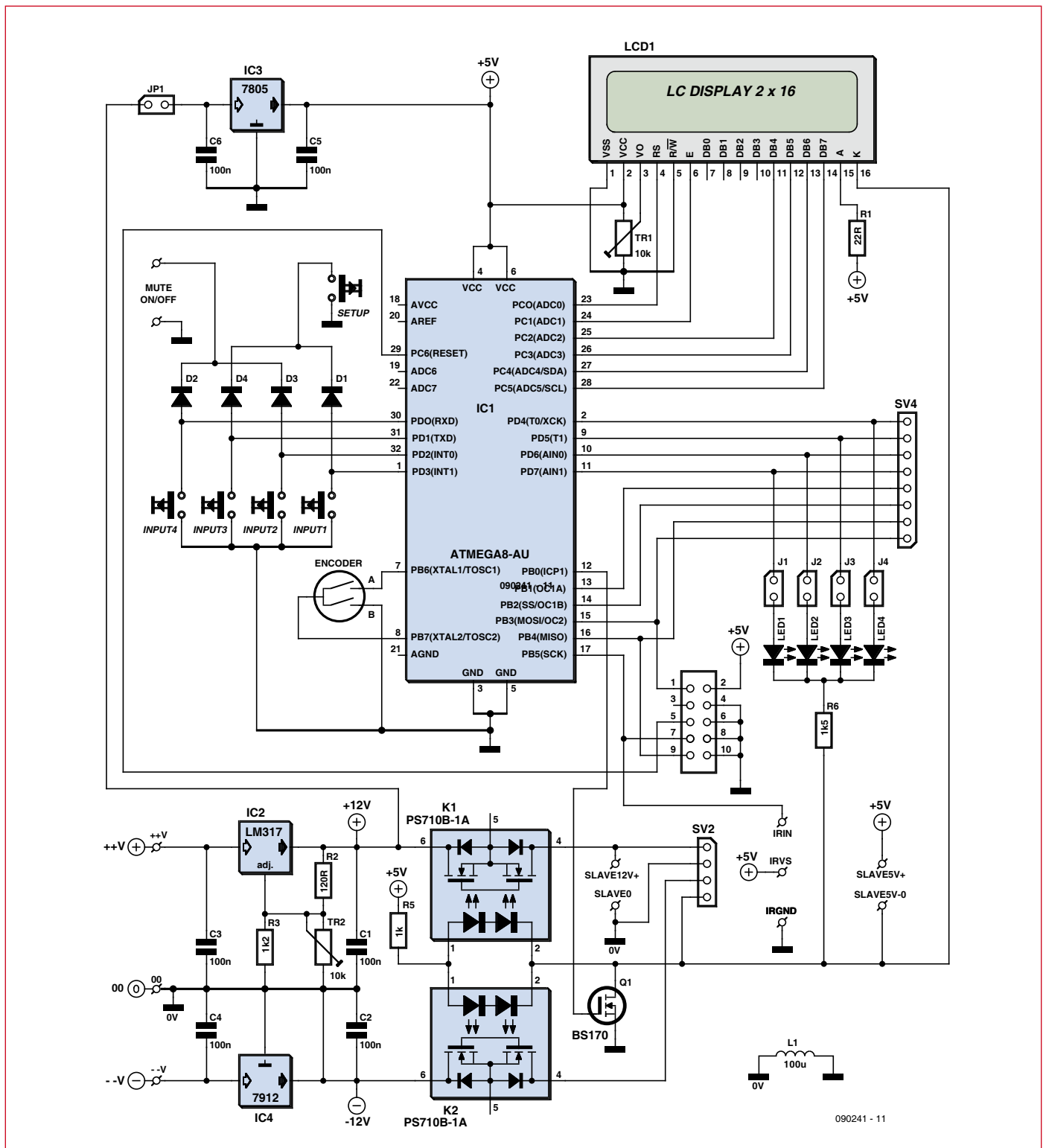

Figure 1. The controller board contains the ATmega8, the display, all controls and the voltage regulators.

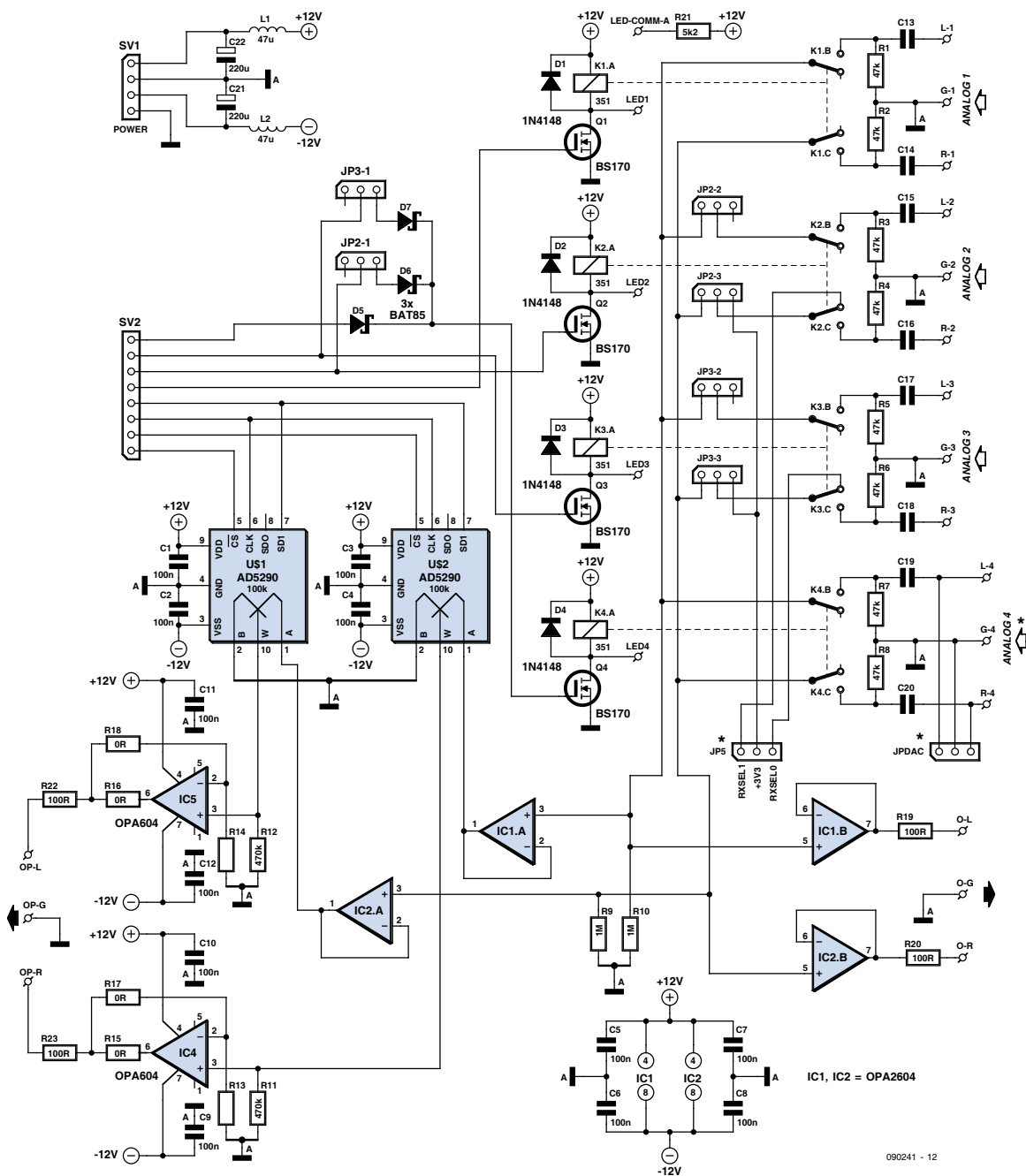

Figure 2. On the analogue board you'll find all analogue inputs and outputs, the digital potentiometers and a number of buffer stages.

- The facility to adjust the volume slightly for each input, compensating for any differences in input levels.
- Remote control using an RC5 compatible remote control. The preamp reacts to address 16 for HIFI.
- A mute function that works by briefly pressing the volume control (encoder knob with a built-in push button).

- And last but not least, the facility to turn everything on and off by pressing the volume control for 3 seconds. That way there is no need to add an on/off switch to the (small) front panel.

Two-part circuit

The circuit consists of two parts: 1. The controller board with an ATmega8, a 2x16 LCD display, the encoder control, the input selectors, the voltage regu-

lators and slave outputs. 2. The analogue board with four input relays, two AD5290-100Ks and all the opamps.

Controller section

If we look at the circuit diagram for the controller section (Figure 1), we'll see an ATmega8 at the heart of the circuit. This employs an internal RC oscillator as the clock. Make sure that this is set to 8 MHz in the fuse-bit settings. At the top is the LCD display that is driven in 4-bit mode by pins PC0 to

PC5. Preset TR1 is used to adjust the contrast of the LCD (positive voltage contrast). R1 is the current limiting resistor for the backlight LEDs (note that the value of this resistor is dependent on the type of LCD used). The input selection happens via push buttons INPUT1 to 4. These pull PD0 to PD3 to ground respectively. The internal pull-up resistors of the ATmega8 have been activated in the code so these pins are normally high.

In order to save on the number of I/O pins, the Setup button is connected to Input buttons 1 and 3 via two diodes. When the Setup button is pressed it results in both PD1 and PD3 being pulled low. This condition signals to the code that it should jump to the Setup label (If Pind.1 = 0 And Pind.3 = 0 Then Goto Setup).

The same principle is used for the MUTEONOFF push button. The name MUTEONOFF refers to the fact that this button has two functions: a short press = mute, a press for more than 3 s = on/off.

We now come to pins PD4 to PD7. These drive the input relays via BS170 MOSFETs. Four LEDs (LED 1 to 4) give a visual indication of the input selected. The value of the current limiting resistor (R6) is dependent on the type of LED used. When selecting the resistor you have to make sure that the maximum source current of the ATmega8 (20 mA) isn't exceeded. A value of 1k5 works well with low-current LEDs taking 2 mA.

Several pins from Port B are used to create the control signals for the two digital potentiometers on the analogue board. These are Data out (PB1), Clock (PB2) and chip selects CS1 & CS2 (PB3 and PB4). It would have been possible to use only one chip select signal since the AD5290s can be daisy-chained and the data could be sent as 16 bits. However, it was decided to keep them separate as that would make it possible to add a balance control to the software (at this point in time it hasn't been added yet).

The ISP connector also connects to port B, but this shouldn't require any further explanation. Connectors SV4 and SV2 carry all connections between the two boards.

From the circuit diagram can be seen that the rotary encoder is connected to PB6 and PB7. The author used a SW-ROT-02 made by Voti, which has a built-in push button that is used here for the MUTEONOFF function. If you decide to use a different type of

encoder you should make sure that it is connected according to the example circuit given with Bascom (this is found in the Help file under 'encoder').

When the circuit is switched on, port PB0 puts a BS170 (Q1) into conduction. This then pulls the cathode of the LCD backlight to ground, as well as the cathodes of the two NEC PS710B-1A solid-state relays. In this way the symmetrical supply is turned on for the analogue board.

In the circuit there are also several slave connections for both 12 V as well as 5 V (note that for the 5 V the ground connection is switched!). These connections are used by the author to drive relays, which turn on a power amplifier and an optional A/D converter.

A standard IR receiver takes care of the reception of infrared signals. It is connected to pins IRIN, IRVS and IRGND. The IR data goes to PB5 of the ATmega.

The voltage regulators for the symmetrical supply are also on this board. They consist of an LM317 and a 7912. With the use of preset TR2 the +12 V line can be adjusted, making the supply exactly symmetrical. There is also a separate 5 V regulator for the controller and the LCD. If there is a jumper across JP1 the voltage for the 7805 will be derived from the LM317. In that case there will be a voltage drop of 7 V across the 7805 and this would have to dissipate a lot of heat. A good heat-sink is therefore a must. It is also possible to connect the 7805 to a separate 9 V supply via pin 2 of JP1. This supply would have to be on at all times, otherwise the preamp couldn't be turned on or off via the remote control. Should, for some reason or other, the supply fail then all settings will be saved in the internal NVRAM of the ATmega (Bascom: ERAM).

As you can see, there are many options for the power supply. The two NEC PS710B-1A relays aren't strictly necessary (they can be left out and replaced by a wire link across pins 4 and 6), but then the 12 V slave function will no longer be available.

For the power supply a small mains transformer with a secondary of 2x12 V/7 VA is sufficient, along with a bridge rectifier and a few electrolytic capacitors.

The source code is, as mentioned earlier, written in Bascom and can be freely downloaded from the Elektor website as file # 090241-11.zip.

ps

- **Display lighting:** For standard green backlights the voltage drop across the LEDs is about 4 V. For white backlights this is significantly lower at about 3.2 V. Refer to the datasheet to find the exact voltage and adapt the value of R1 accordingly.

- **LED drivers:** If you prefer to use LEDs that require a larger current you'll find that connections have been made available for this on the analogue board. In this case they're driven by a BS170, along with the associated relay (max. 500 mA).

- Take care that the **AD5290 100K** digi-pots get the correct supply voltages. They are extremely sensitive to this! It will be catastrophic if one side of the symmetrical supply isn't connected!

- If you make **IC4** and **IC5** amplify, remember that you may have to add a small capacitor across the feedback loop to prevent oscillations.

- You should also bear in mind that **not all types of opamp** remain stable when configured as voltage followers (such as the well-known OPA627). In that case you will need to add a compensation capacitor, or you could make the opamp amplify the signal a little bit.

- **Programming:** The ATmega8 has a fairly large number of fuse-bits. If you're not fully familiar with these, it would be a good idea to program the chip first in a separate programmer with a TQFP32 adapter and only then solder it onto the board.

- If you do want to **program the ATmega8 on-board**, remember that the IR receiver and the connections to the analogue board use the same pins as the ISP, so should not yet be connected.

- From the Bascom source code can be seen that the code for the **mute command** from the **remote control** is set to 5 instead of the usual 13. This was done because the author's universal remote control didn't have a mute function in hifi mode. To get round this, the button for input-5 was redefined as a mute button.

- **Compiling the program** yourself has the advantage that you can customise the names of the inputs to your own liking. This also applies to the sensitivity of the rotary encoder in relation to the volume.

You'll then have three analogue inputs and one digital input available. But this can be taken one stage further. With a CS8416 digital audio interface receiver it is possible to set it to hardware mode and use the RXSEL0 and RXSEL1 pins to drive the internal S/PDIF input multiplexer. In this way you can select one of the four digital inputs (RXP0 to RXP3). (Refer to the

JPIN3-3. When input 3 is selected, RXSEL0 = 0 and RXSEL1 = 1. And when input 4 is selected, only K4 turns on and RXSEL0 = 1, RXSEL1 = 1. In that case input RXP3 of the CS8416 is selected. Bear in mind that analogue inputs 2, 3 and 4 are no longer available in this configuration, since they've been 'replaced' by the digital inputs of the CS8416 in Figure 3.

front panel for the buttons, display and IR receiver. The board with the analogue circuit is mounted at the back of the case, so that the phono sockets poke through holes in the back. You can use ribbon cable for the wiring between the boards, since no audio signals are carried across them.

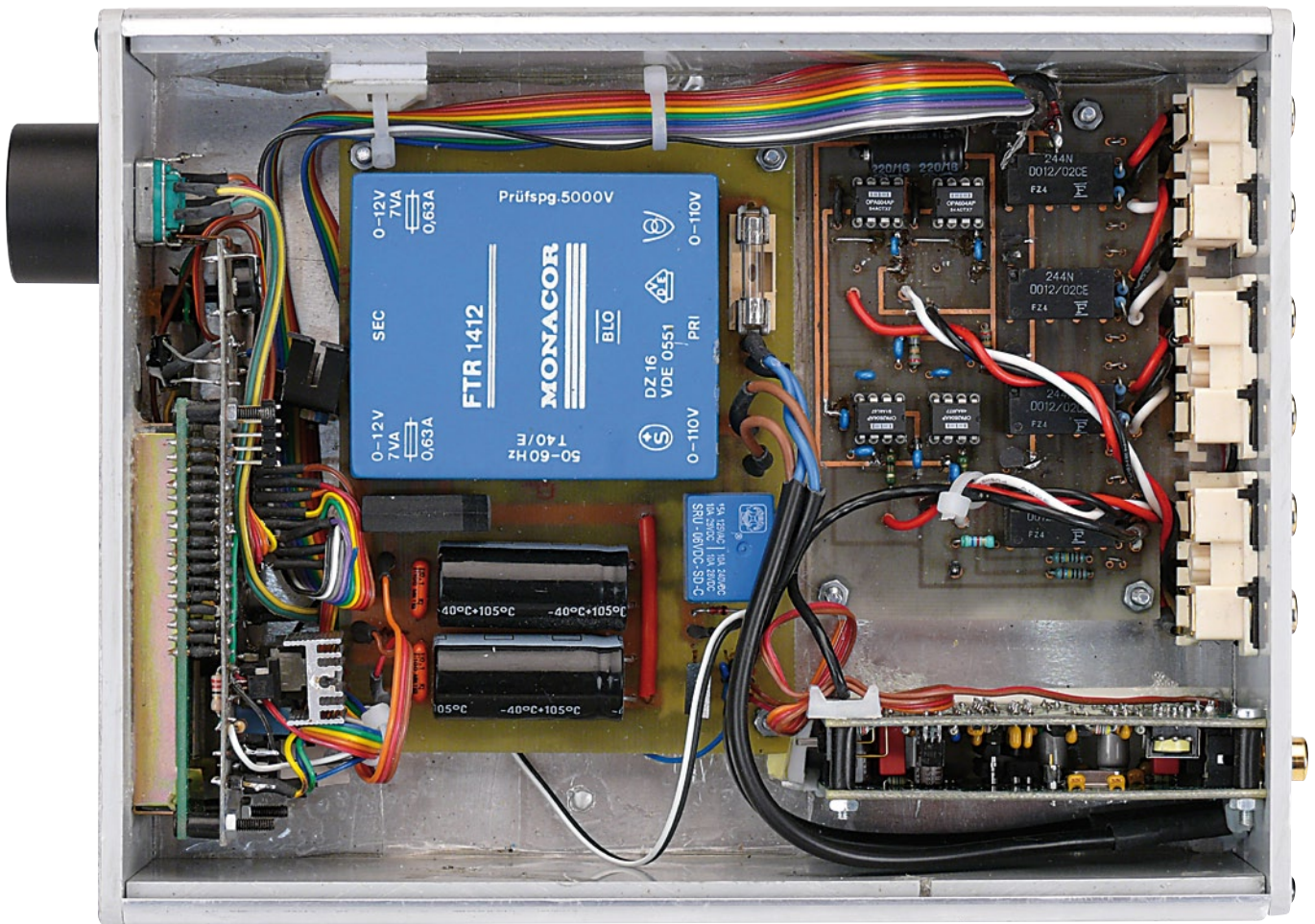

Figure 5. A quick look at the prototype. At the back on the right is a small D/A converter made by AMB (Y1 DAC, see www.amb.org).

example of such a circuit in **Figure 3.**) If we now move the jumpers on JPIN2-1, JPIN2-2 and JPIN2-3 such that pins 2&3 are connected, the switch signal for input 2 will be connected via D6 to relay 4. This means that when input 2 is selected it will drive both relay 2 as well as relay 4. The audio output of the DAC will then be connected to IC1a and IC2a via K4 and K2 ensures that the RXSEL1 pin of the CS8416 is pulled low via JPIN2-3. The result: RXSEL0 = 1, RXSEL1 = 0 and the respective digital input in Figure 3 is selected. The same applies to JPIN3-1, JPIN3-2 and

Practical construction

The author has designed PCBs for both circuits, which can be downloaded from the Elektor website (Eagle format, file # 090241-1.zip). The construction of the preamp is quite straightforward, and the photos of the prototype can be used as guidelines. The enclosure for the circuit can be fairly small. The controller board is mounted behind the front panel, where the rotary encoder, the setup switch, the four input selection buttons and the display are. You will need to make suitable holes in the

In the middle of the case there should be room to mount a mains power supply, which could easily fit on an experimenter's board. Do make sure that you keep a sufficient isolation clearance between the primary and secondary sides!

(090241-1)



NOW, THERE'S EVEN MORE TO DISCOVER.

NEW:
exclusive access to
www.elektor-plus.com!

The upgraded Elektor- PLUS subscription

Elektor PLUS advantages

- All 11 issues including the Summer Circuits edition
- Included in your PLUS subscription: Annual DVD 2009
- **20%** cheaper than normal retail price
- Welcome gift worth £25
- Up to **40% discount** on selected Elektor products
- Elektor is delivered to your doorstep every month
- Read your copy before everyone else
- **NEW:** On your personalized Elektor PLUS website, you have permanent access to the three latest issues of the magazine in PDF format, as well as to a fast Elektor search engine!

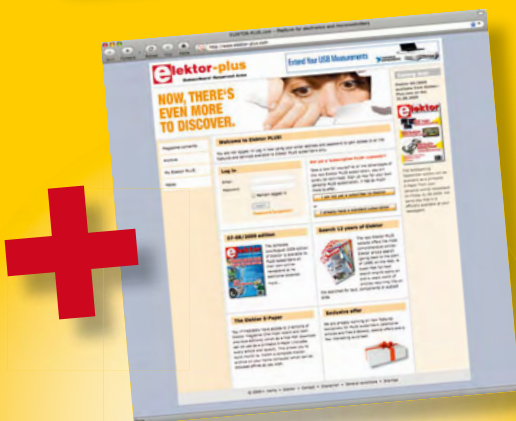

www.elektor.com/subs • Tel. +44 (0) 20 8261 4509

NEW!

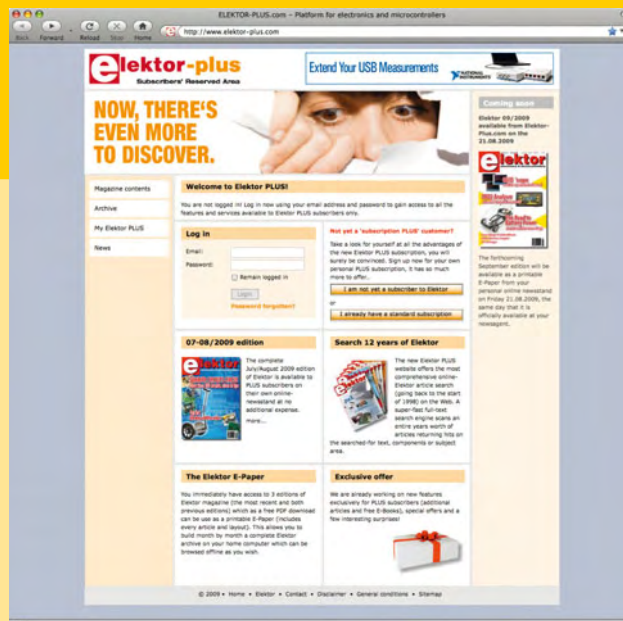

- Online instant access to the recent three editions ✓
- Extensive searching in all editions ✓
- Extra articles and free E-books ✓

- ... soon to come: more extras, offers and bombshells ✓

When taking out an Elektor PLUS subscription you get **exclusive access** to the new website www.elektor-plus.com where the three latest editions of Elektor magazine are available in the form of pdf files (i.e. the current issue and the two preceding ones). With a simple click you download the complete issue (front to back!) or any single article. www.elektor-plus.com also supplies the most extensive Elektor search engine found on the web. However the upgraded PLUS subscription offers many more interesting extras like free E-books and supplementary articles.



Or use the subscription order form near the end of the magazine.

Hexadoku

Puzzle with an electronics touch

As usual, "towards the back of the magazine" we present a new instalment of our popular Hexadoku puzzle. Put electronics formulas out of your mind for a change and take on a different challenge. Send your solution to Elektor and enter a prize draw for an E-blocks Starter Kit Professional and three Elektor Shop vouchers. Have fun!

The instructions for this puzzle are straightforward.

In the diagram composed of 16 x 16 boxes, enter numbers such that **all** hexadecimal numbers 0 through F (that's 0-9 and A-F) occur once only in each row, once in each column and in each of the 4x4 boxes (marked by the thicker black lines). A

number of clues are given in the puzzle and these determine the start situation.

All correct entries received for each month's puzzle go into a draw for a main prize and three lesser prizes. All you need to do is send us the numbers in the grey boxes. The puzzle is also available as a **free download** from the Elektor website

SOLVE HEXADOKU AND WIN!

Correct solutions received from the entire Elektor readership automatically enter a prize draw for an

E-blocks Starter Kit Professional

worth **£300**

and three **Elektor SHOP Vouchers** worth £40.00 each.



We believe these prizes should encourage all our readers to participate!

The competition is not open to employees of Elektor International Media, its business partners and/or associated publishing houses.

PARTICIPATE!

Please send your solution (the numbers in the grey boxes) by email to: **hexadoku@elektor.com** - Subject: **hexadoku 10-2009** (please copy exactly).

Note: new email address as of this month!

Include with your solution: **full name and street address.**

Alternatively, by fax or post to: **Elektor Hexadoku**

Regus Brentford - 1000 Great West Road - Brentford TW8 9HH

United Kingdom - Fax (+44) 208 2614447

The closing date is **1 November 2009.**

PRIZE WINNERS

The solution of the July/August 2009 Hexamurai is: **BCE56.**

The **E-blocks Starter Kit Professional** goes to: Arwin J. Vosselman (Netherlands).

An Elektor SHOP voucher worth £40.00 goes to: Dominik Johe (Germany), Gareth Hayes (United Kingdom) en Michel-Hugues Michel (France).

Congratulations everybody!

1	2			B		A	8	C			F	E	6	3	
E			B	F					D	5	7	9			
	0	D			4	5			A	6		8	F	2	
		3		C	9		E	4			B				
	9	F	3	6	8			0	B	1		C	E		
				9		1					D		7		
4		E	6		C	0	7			A	2	B		F	9
	C											0			1
	7			E	A			F	8		6				1
8	D		4	1			5		2			0	B	F	
A							7		9	6			8	4	
6	F		1		B			4	0	A		7			
0	A	6		2		9					4	B		3	
B				4	3	7							8		
D		1			6	8	0			3		9		5	
3		7	8	5				A	E		D		2	0	

E	D	2	7	5	3	C	1	A	6	8	F	0	B	4	9
F	5	C	A	8	0	E	7	9	4	B	3	1	D	2	6
3	9	4	8	2	F	B	6	5	D	1	0	E	A	7	C
B	0	1	6	A	9	4	D	E	C	2	7	F	5	3	8
8	C	7	E	B	6	3	4	F	9	0	1	A	2	5	D
1	3	0	B	E	2	7	5	D	A	4	6	9	8	C	F
D	4	A	F	9	C	8	0	2	5	7	E	6	3	1	B
5	6	9	2	D	1	F	A	3	8	C	B	7	E	0	4
7	F	E	4	0	A	5	3	B	2	6	C	D	9	8	1
A	B	D	9	1	4	6	2	7	3	E	8	5	C	F	0
6	2	8	5	F	E	9	C	1	0	D	A	4	7	B	3
0	1	3	C	7	8	D	B	4	F	5	9	2	6	E	A
4	A	5	D	C	7	0	9	8	1	3	2	B	F	6	E
2	8	F	1	3	B	A	E	6	7	9	4	C	0	D	5
9	E	6	0	4	5	2	8	C	B	F	D	3	1	A	7
C	7	B	3	6	D	1	F	0	E	A	5	8	4	9	2
6	7	4	D	9	B	0	1	5	3	A	E	8	F	C	2
9	2	0	E	3	A	8	4	D	C	F	7	5	1	B	6
A	C	1	B	5	F	2	7	9	4	8	6	0	E	D	3
F	3	5	8	C	E	D	6	1	2	B	0	A	9	7	4
2	E	D	7	1	0	3	8	F	A	C	B	9	4	6	5
C	9	6	0	F	5	7	A	8	D	3	4	B	2	E	1
1	B	F	A	D	C	4	E	6	5	2	9	7	3	8	0
5	8	3	4	6	2	9	B	7	0	E	1	D	C	F	A
4	F	E	6	8	7	A	D	3	9	1	C	2	0	5	B
7	5	2	C	B	4	1	9	E	6	0	8	F	A	3	D
B	A	8	1	0	3	C	2	4	F	5	D	E	6	9	7
0	D	9	3	E	6	F	5	2	7	A	1	8	4	C	7
8	0	7	9	A	D	5	3	C	1	6	F	4	B	2	E
E	6	C	5	4	8	B	0	A	7	9	2	3	D	1	F
3	4	A	F	2	1	E	C	B	8	D	5	6	7	0	9
D	1	B	2	7	9	6	F	0	E	4	3	C	5	A	8
B	3	C	A	9	D	F	2	6	7	5	0	E	1	4	8
D	4	F	5	0	3	8	6	1	E	A	2	7	C	B	9
1	E	7	2	B	C	5	A	4	3	8	9	F	D	6	0
6	8	9	0	7	1	E	4	F	D	B	C	5	3	A	2
3	7	B	8	4	0	C	E	2	5	1	D	9	A	F	6
F	1	4	E	A	5	2	B	7	9	3	6	C	8	0	D
A	9	5	C	D	7	6	1	0	F	E	8	2	B	3	4
0	2	D	6	8	F	9	3	C	B	4	A	1	5	7	E

Philbrick K2-W, the mother of all op amps



GAP/R vintage K2-W, K2-X and K2-P op amps. (Author's collection)

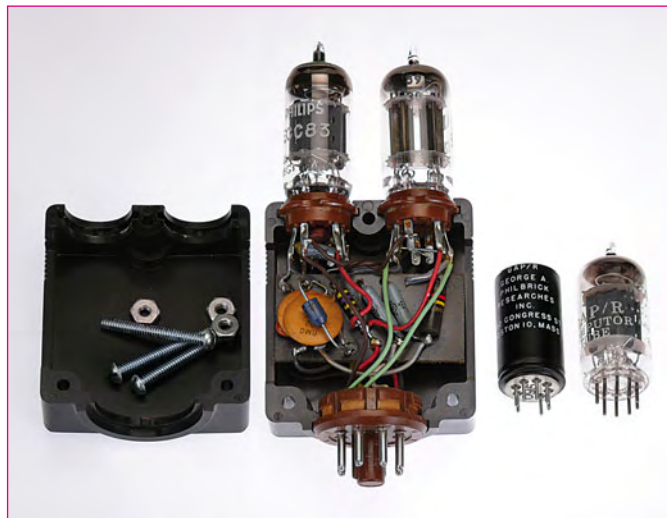

Embree Electronics C/50 op amp (opened up for curiosity), GAP/R 'Computer' tube and GAP/R 'Airpax' A-175 DC-to-AC chopper. (Author's collection)

**By Jan Didden
(The Netherlands)**

One popular belief among the all-transistor generation of electronics enthusiasts is that operational amplifiers (op amps) came after engineers learned to put many transistors on a chip carrier. In fact, op amps are much older.

As with many technologies, the development of op amps was initially strongly driven by military requirements. World War 2 saw developments in largely mechanical contraptions for mathematical problems like aiming anti-aircraft guns and calculating the optimum point to release bombs over enemy targets. Functionally, the devices consisted mostly of amplifiers, integrators and differentiators; very complex instruments comprising, for instance, gear wheels with logarithmically-arranged cogs. These were phased out gradually and replaced with electronic function blocks called operational amplifiers: amplifier blocks that could be configured to perform an operation: amplification, summing, differentiation and integration to name just the simplest ones. The first op amp type circuit design published was probably by Lovell and Parkinson of Bell Labs for the M9 anti-aircraft gun director built by Western Electric. Later on, Loebe

Julie at Columbia University consulted for the George A Philbrick Researches company (GAP/R), to develop the electronic module for a bombing simulator for the US Armed Forces. It was Philbrick who saw the commercial potential, and from 1952 GAP/R offered its op amps for

commercial use as well. The first device was the K2-W shown in **Figure 1**. To this day the circuit configuration is the basis of many high-gain, balanced-input circuits including the balanced differential stage, cathode-coupled with a large cathode resistor acting as a current source. A differential-input signal unbalances the

differential pair and causes a differential output signal at the anodes. The second pair buffers this signal with cathode-followers and provides a single-ended output. Later circuits improved on this with, for instance, a real current source to bias the input pair (which came to be known as a 'long-tailed pair') and differential outputs, see **Figure 2**. For amusement only, if you compare this to the circuit in **Figure 3** of an NE5532 op amp, the pedigree is clear.

The K2-W used bipolar supplies of ± 300 V. The output could swing about ± 50 V peak, and in this spec at least modern op amps are a big step backwards! Other specs were not so hot. The bandwidth was about 100 kHz with a 2 μ s rise time, and an open-loop gain of 15,000. R_{out} was specified as about 1 kOhms.

But the specs itself were of lesser importance compared to the concept behind these units. K2-W's were built as plug-in units that could be configured for a specific function by the user: real operational amplifiers! They were generally not supposed to be used open-loop, but with a feedback circuit to obtain the desired transfer function. Just like today's op amps, several different versions were developed

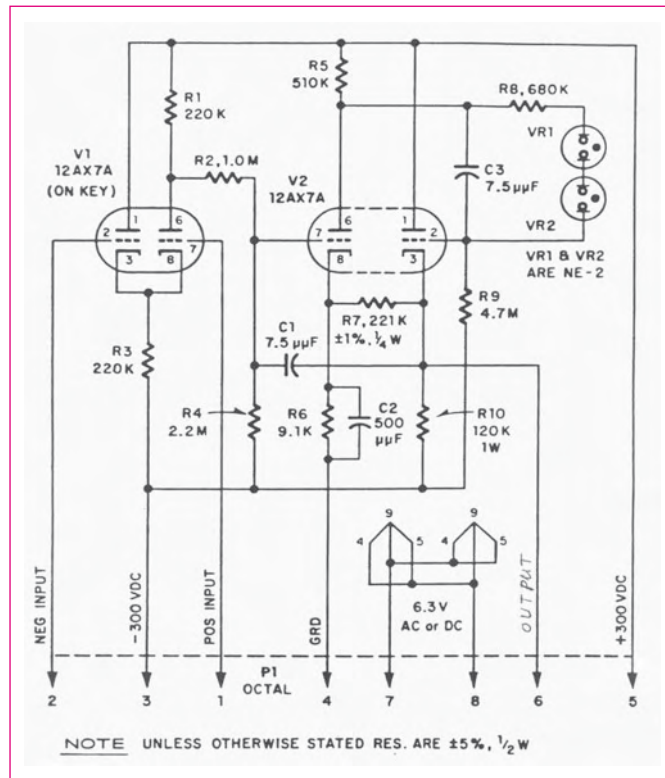

Fig 1. GAP/R K2-W opamp schematic diagram. You could easily build this yourself.

that had slightly different specs for different tradeoffs in the final product: after the K2-W came the K2-X, K2-XA and the K2-P. The K2-XA had double the speed, double the bandwidth, double the output swing and double the gain of the K2-W. These op amps all shared the same base socket connections and could be freely interchanged, similar to today's 'universal' op amp pinouts. The tubes used in the Philbrick units were dual triodes of the 12AX7, 12AU7 12AT7 (ECC83, ECC82, ECC81) family. There were also some specialised plug-in units like mechanical choppers that could take the place of the first double triode to make the unit into a DC amplifier. Philbrick also selected tubes for tighter specs and these were stamped with the company name and the indication 'Computer Tube'. GAP/R consequently used 'computer' in these days, not 'computer'. A wealth of information on these and other Philbrick products may be found at Joe Sousa's site [2].

With the success of these op amps, competitors tried to jump the bandwagon, of course. One outfit, Embree Electronics Corp. offered the C/50/BP, very similar to the Philbrick units, except that mechanically it was different, and it could be opened up for repair if necessary. Philbrick's units could not; apparently they had enough trust in their products to believe that repair would not be necessary over the lifetime of the unit, or maybe the price was low enough (for the military) to treat it as a consumable rather than a repairable item. Another similarity to modern IC op amps.

GAP/R took the concept one step further and developed a sort of universal unit that would take up to three op amp plug-ins plus an additional tube, the K3. This unit offered a higher level of integration and was actually called an 'analog computer', see [1]. With the development of the op amp, application notes and books on how to use them started to appear as well. One early GAP/R engineer, Bob Pease who until recently worked at National

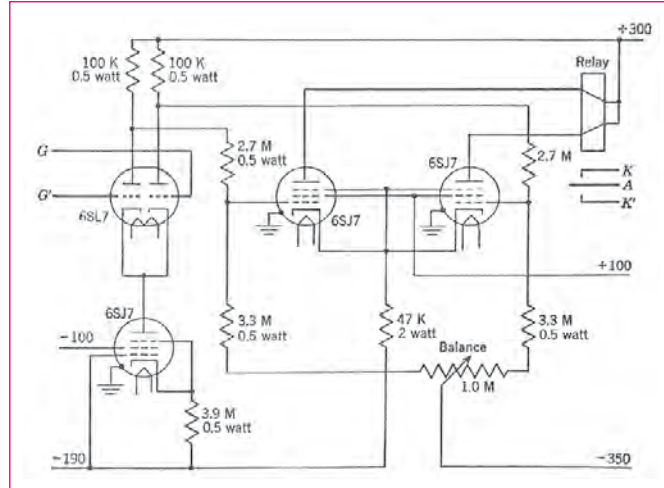

Figure 2. Tube-based 'long tailed pair'.

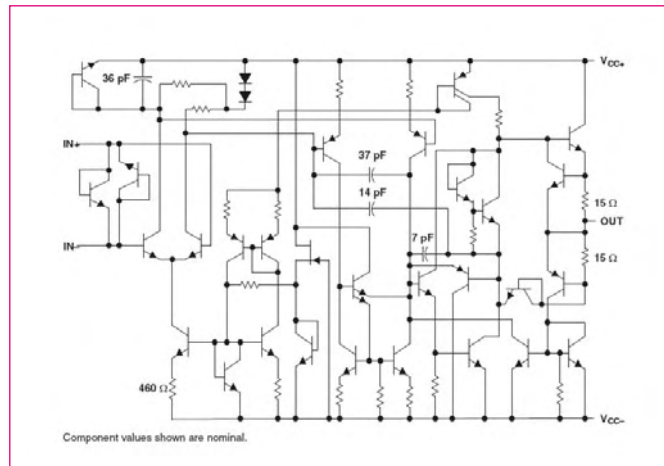

Figure 3. Internal schematic of the industry standard NE5532 monolithic opamp.

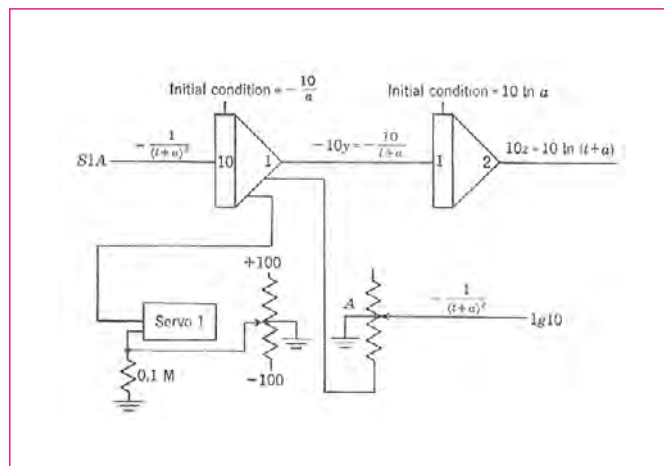

Figure 4. Using op amps to obtain the logarithmic of an input signal.

Semiconductor, wrote Philbrick's very first application note numbered 'R1'. Bob's stories about his early years at GAP/R can be found at [3].

Capt. Clarence L Johnson, an engineer with the US Air Force and Professor at the Department of Mathematics at the Air Force Institute of Technology, wrote "Analog Computer Techniques", published in 1956. This book gives a fascinating insight into the use of op amps to actually 'simulate' (as it was called) electromechanical problems, as well as their use in complex constellations of electromechanical servos and electronic op amps.

Figure 4 shows a simple circuit to generate a logarithmic function.

While the military prompted the developments of tube op amps, they could also be relied on to keep using them for a long, long time. The Nike anti-aircraft missile system used tube op amps and wasn't scrapped from NATO inventory until the late 1990s. I found some NOS K2-W's gathering dust at a military depot/repair unit that finally got rid of their stock in 2003.

We often see the monolithic opamp as a revolution in electronics. But with the concept of operational amplifiers firmly rooted in vacuum tube technology on the one hand, and the rapid development of the transistor and the integrated circuit on the other, monolithic op amps were just the next logical step in a technological evolution, and perhaps less than a conceptual breakthrough.

(090276-1)

Internet Links

- [1] www.philbrickarchive.org/k3_series_components.htm
- [2] www.philbrickarchive.org/
- [3] www.national.com/rap/

Author email:

jandidden01@gmail.com

Further Reading

Analog Computer Techniques, Clarence L Johnson, McGraw-Hill, 1956

ELEKTOR SHOWCASE

To book your showcase space contact **Huson International Media**

Tel. 0044 (0) 1932 564999 Fax 0044 (0) 1932 564998

AVIT RESEARCH

www.avitresearch.co.uk

USB has never been so simple... with our USB to Microcontroller Interface cable. Appears just like a serial port to both PC and Microcontroller, for really easy USB connection to your projects, or replacement of existing RS232 interfaces.



See our webpage for more details. From £10.00.

BLACK ROBOTICS

www.blackrobotics.com

Robot platforms and brains for research, hobby and education.

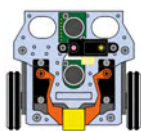

- Make your robot talk!
- TalkBotBrain is open-source
- Free robot speech software
- Robot humanisation technology
- Mandibot Gripper Robot

ByVac

www.byvac.com

- PIC32 With BASIC
- ARM With Forth
- USB to I2C
- Serial Devices
- VT100 LCD Displays

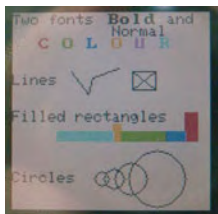

DECIBIT CO.LTD.

www.decibit.com

- Development Kit 2.4 GHz
- Transceiver nRF24L01
- AVR MCU ATmega168



DESIGNER SYSTEMS

<http://www.designersystems.co.uk>

Professional product development services.

- Marine (Security, Tracking, Monitoring & control)
- Automotive (AV, Tracking, Gadget, Monitoring & control)
- Industrial (Safety systems, Monitoring over Ethernet)
- Telecoms (PSTN handsets, GSM/GPRS)
- AudioVisual ((HD)DVD accessories & controllers)

Tel: +44 (0)1872 223306

EASYDAQ

www.easydaq.biz

- USB powered, 4 relays + 4 DIO channels
- Will switch 240VAC @ 10 a
- Screw terminal access
- LabVIEW, VB, VC
- Free shipping
- From £38



Design & supply of USB, USB Wireless, Ethernet & Serial, DAQ, Relay & DIO card products.

info@easydaq.biz

EASYSYNC

<http://www.easysync.co.uk>

EasySync Ltd sells a wide range of single and multi-port USB to RS232/RS422 and RS485 converters at competitive prices.



ELNEC

www.elnec.com

- device programmer manufacturer
- selling through contracted distributors all over the world
- universal and dedicated device programmers
- excellent support and after sale support
- free SW updates
- reliable HW
- once a months new SW release
- three years warranty for most programmers



FIRST TECHNOLOGY TRANSFER LTD.

<http://www.ftt.co.uk>

- Training and Consulting for IT, Embedded and Real Time Systems
- Assembler, C, C++ (all levels)
- 8, 16 and 32 bit microcontrollers
- Microchip, ARM, Renesas, TI, Freescale
- CMX, uCOSII, FreeRTOS, Linux operating systems
- Ethernet, CAN, USB, TCP/IP, Zigbee, Bluetooth programming



FUTURE TECHNOLOGY DEVICES

<http://www.ftdichip.com>

FTDI designs and sells USB-UART and USB-FIFO interface i.c.'s.

Complete with PC drivers, these devices simplify the task of designing or upgrading peripherals to USB



HAMEG® Instruments

A Rohde & Schwarz Company

- Oscilloscopes
- Power Supplies
- Radio Frequency Measuring Instruments
- Programmable Measuring Instruments

Great Value in Test & Measurement

www.hameg.com

HEXWAX LTD

www.hexwax.com

World leaders in Driver-Free USB ICs:

- USB-UART/SPI/I2C bridges
- TEAleaf-USB authentication dongles
- expandIO-USB I/O USB expander
- USB-FileSys flash drive with SPI interface
- USB-DAQ data logging flash drive

LONDON ELECTRONICS COLLEGE

<http://www.lec.org.uk>

Vocational training and education for national qualifications in Electronics Engineering and Information Technology (BTEC First National, Higher National NVQs, GCSEs and GCEs). Also Technical Management and Languages.



FLEXIPANEL LTD

www.flexipanel.com

TEAclippers - the smallest PIC programmers in the world, from £20 each:

- Per-copy firmware sales
- Firmware programming & archiving
- In-the-field firmware updates
- Protection from design theft by subcontractors



LCDMOD KIT

<http://www.lcdmodkit.com>

Worldwide On-line retailer

- Electronics components
- SMT chip components
- USB interface LCD
- Kits & Accessories
- PC modding parts
- LCD modules



products and services directory

www.elektor.com

MQP ELECTRONICS

www.mqp.com

- Low cost USB Bus Analysers
- High, Full or Low speed captures
- Graphical analysis and filtering
- Automatic speed detection
- Bus powered from high speed PC
- Capture buttons and feature connector
- Optional analysis classes



RFID COMPONENTS

<http://www.apdanglia.org.uk>

For DIY, OEM's & Experimenters

- EM4100 Cards .99 p (Prices inc vat)
 - Keyfobs £1.09
 - R/W Keyfobs £1.65
 - RFID Coils £2.95
 - RFID PCB with RS232 port
 - RFID IC's EM4095 - U2270B
 - microRFID module (similar to Core ID12)
 - Free Reader download - Technical pages
- Order online 24 hrs - Tel: 01244 520684



ROBOT ELECTRONICS

<http://www.robot-electronics.co.uk>

Advanced Sensors and Electronics for Robotics

- Ultrasonic Range Finders
- Compass modules
- Infra-Red Thermal sensors
- Motor Controllers
- Vision Systems
- Wireless Telemetry Links
- Embedded Controllers



ROBOTIQ

<http://www.robotiq.co.uk>

Build your own Robot!

Fun for the whole family!

- Meccano™ Compatible
- Computer Control
- Radio Control
- Tank Treads
- Hydraulics



Internet Technical Bookshop,

1-3 Fairlands House, North Street, Carshalton, Surrey SM5 2HW

email: sales@robotiq.co.uk Tel: 020 8669 0769

www.elektor.com

USB INSTRUMENTS

<http://www.usb-instruments.com>

USB Instruments specialises in PC based instrumentation products and software such as Oscilloscopes, Data Loggers, Logic Analysers which interface to your PC via USB.



VIRTINS TECHNOLOGY

www.virtins.com

PC and Pocket PC based virtual instrument such as sound card real time oscilloscope, spectrum analyzer, signal generator, multimeter, sound meter, distortion analyzer, LCR meter. Free to download and try.



CANDO - CAN BUS ANALYSER

<http://www.cananalyser.co.uk>

- USB to CAN bus interface
- USB powered
- FREE CAN bus analyser S/W
- Receive, transmit & log. CAN messages
- ISO11898 & CAN 2.0a/2.0b compliant
- Rugged IP67 version available



netronics

SHOWCASE YOUR COMPANY HERE

Elektor Electronics has a feature to help customers promote their business, Showcase - a permanent feature of the magazine where you will be able to showcase your products and services.

- For just £242 + VAT (£22 per issue for eleven issues) Elektor will publish your company name, website address and a 30-word description
- For £363 + VAT for the year (£33 per issue for eleven issues) we will publish the above plus run a 3cm deep full colour

image - e.g. a product shot, a screen shot from your site, a company logo - your choice

Places are limited and spaces will go on a strictly first come, first served basis. So-please fax back your order today!

I wish to promote my company, please book my space:

- Text insertion only for £242 + VAT
- Text and photo for £363 + VAT

NAME: ORGANISATION:

JOB TITLE:

ADDRESS:

..... TEL:

PLEASE COMPLETE COUPON BELOW AND FAX BACK TO 00-44-(0)1932 564998

COMPANY NAME

WEB ADDRESS

30-WORD DESCRIPTION

.....

.....

.....

.....

Going Strong

A world of electronics
from a single shop!

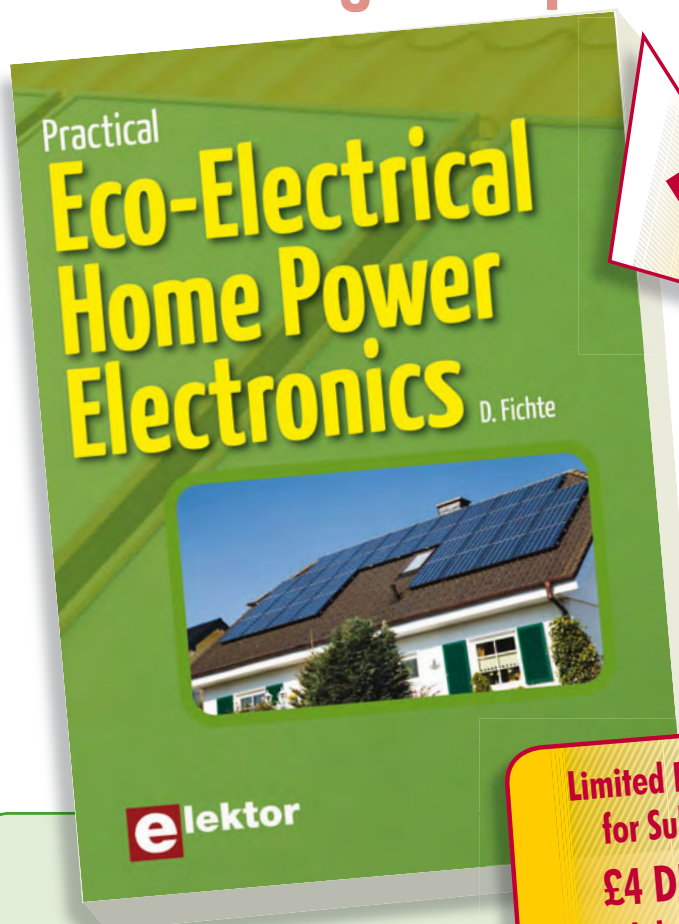

NEW!

Limited Period Offer
for Subscribers!
£4 DISCOUNT
www.elektor.com/october

Look into the electronics of eco-power

Practical Eco-Electrical Home Power Electronics

This book "opens the hood" and looks into the electronics of eco-power. Explained from circuit diagrams of commercially-available products are the electronics of affordable eco-electrical power components such as solar chargers, battery inverters, and off-line chargers. Not only are circuits analysed in detail, design modifications are presented, and basic design principles applied so that you can do your own improvements and achieve high performance at low cost. The effects of various kinds of loads on the power distribution lines reveal potential problems and insights. Included are power circuits useful to homesteaders, such as LED and fluorescent lamp drivers, optimal wind converters, and improved system-level architecture for eco-power. The book ends with an alternative solar power technique based on thermal instead of photovoltaic conversion, using thermoelectric modules, and storing energy in a tank instead of batteries.

192 pages • ISBN 978-0-905705-83-5 • £24.90 • US \$39.90

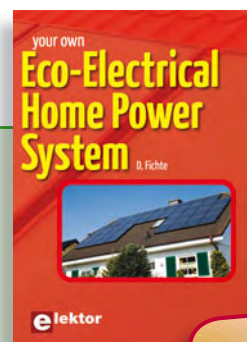

New!

Home electric power

Your own Eco-Electrical Home Power System

This book provides the semi-technical, power-conscious homeowner a place to begin in the quest for home electric power. Both the essential principles and detailed information on how to build or maintain a home electric system off the utility grid are presented in an easy-going style. This booklet will help you to safeguard or develop your own home electricity supply. It contains step-by-step calculations, practical details, examples, electric system problems with remedies and much more.

96 pages • ISBN 978-0-905705-82-8
£16.50 • US \$26.00

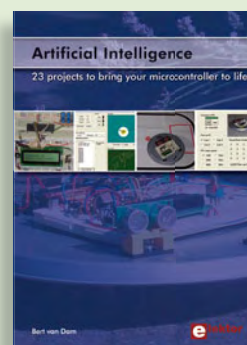

Bring your microcontroller to life

Artificial Intelligence

This book contains 23 special and exciting artificial intelligence machine-learning projects, for microcontroller and PC. Learn how to set up a neural network in a microcontroller, and how to make the network self-learning. Or discover how changing a fitness function results in a totally different behavior. Several artificial intelligence techniques are discussed: expert system, neural network, subsumption, emerging behavior, genetic algorithm, cellular automata, roulette brains etc.

256 pages • ISBN 978-0-905705-77-4
£32.00 • US \$46.00

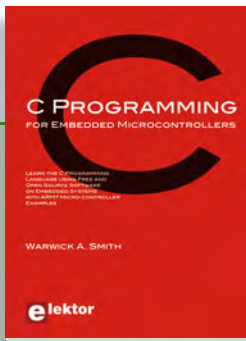

Learn by doing

C Programming for Embedded Microcontrollers

If you would like to learn the C Programming language to program microcontrollers, then this book is for you. No programming experience is necessary! You'll start learning to program from the very first chapter with simple programs and slowly build from there. Initially, you program on the PC only, so no need for dedicated hardware. This book uses only free or open source software and sample programs and exercises can be downloaded from the Internet.

324 pages • ISBN 978-0-905705-80-4
£32.50 • US \$52.00

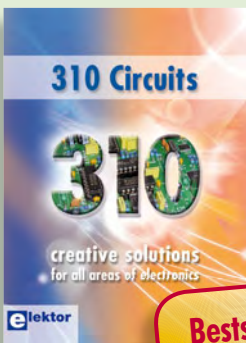

Bestseller!

Creative solutions for all areas of electronics

310 Circuits

310 Circuits, tips and design ideas in one book form a treasure trove for every area of electronics: audio and video, hobby and modelling, RF techniques, home and garden, test and measurement, microcontrollers, computer hardware and software, power supplies and chargers – plus of course everything else that does not seem to belong in any of these categories. 310 Circuits contains many complete solutions as well as useful starting points for your own projects.

544 pages • ISBN 978-0-905705-78-1
£29.90 • US \$45.00



Learn more about C# programming and .NET

C# 2008 and .NET programming for Electronic Engineers

This book is aimed at Engineers and Scientists who want to learn about the .NET environment and C# programming or who have an interest in interfacing hardware to a PC. The book covers the Visual Studio 2008 development environment, the .NET framework and C# programming language from data types and program flow to more advanced concepts including object oriented programming. It continues with program debugging, file handling, databases, internet communication and plotting before moving to hardware interfacing using serial and parallel ports and the USB port. It includes a hardware design for a simple oscilloscope using a parallel port and interfacing to analogue and digital I/O using the USB port. This book is complete with many program examples, self assessment exercises and references to supporting videos.

240 pages • ISBN 978-0-905705-81-1
£29.50 • US \$44.50

More information on the
Elektor Website:
www.elektor.com

Elektor
Regus Brentford
1000 Great West Road
Brentford
TW8 9HH
United Kingdom
Tel.: +44 20 8261 4509
Fax: +44 20 8261 4447
Email: sales@elektor.com

elektor
SHOP



Bestseller!

See the light on Solid State Lighting

DVD LED Toolbox

This DVD-ROM contains carefully-sorted comprehensive technical documentation about and around LEDs. For standard models, and for a selection of LED modules, this Toolbox gathers together data sheets from all the manufacturers, application notes, design guides, white papers and so on. It offers several hundred drivers for powering and controlling LEDs in different configurations, along with ready-to-use modules (power supply units, DMX controllers, dimmers, etc.). In addition to optical systems, light detectors, hardware, etc., this DVD also addresses the main shortcoming of power LEDs: heating. Of course, this DVD contains several Elektor articles (more than 100) on the subject of LEDs.

ISBN 978-90-5381-245-7 • £28.50 • US \$54.00



All articles published in 2008

DVD Elektor 2008

This DVD-ROM contains all editorial articles published in Volume 2008 of the English, Spanish, Dutch, French and German editions of Elektor magazine. Using Adobe Reader, articles are presented in the same layout as originally found in the magazine. The DVD is packed with features including a powerful search engine and the possibility to edit PCB layouts with a graphics program, or printing hard copy at printer resolution.

ISBN 978-90-5381-235-8 • £17.50 • US \$35.00

CD/DVD-ROMS



Incl. searchable i-TRIXX archive

DVD i-TRIXX Freeware Collection 2009

This DVD contains 100 nifty freeware applications, tools and utilities for the Windows PC. And as a free extra, it contains the full and searchable (!) i-TRIXX archive, with all the editions up until week 8 of 2009 from i-TRIXX, the e-magazine published by Elektor. Do you feel the need for a decent and reliable antivirus program? A bandwidth monitor which keeps track of your current up and download rate? An application for recording, editing and converting video to any conceivable format? Anonymous surfing from any internet access point from a USB stick? Checking, optimizing and cleaning up your computer? Keeping track of your privacy? You can expect that and much more in the i-TRIXX Freeware Collection 2009.

ISBN 978-90-5381-244-0 • £27.50 • US \$39.50



Completely updated

Elektor's Components Database 5

The program package consists of eight databanks covering ICs, germanium and silicon transistors, FETs, diodes, thyristors, triacs and optocouplers. A further eleven applications cover the calculation of, for example, LED series droppers, zener diode series resistors, voltage regulators and AMVs. A colour band decoder is included for determining resistor and inductor values. ECD 4 gives instant access to data on more than 69,000 components. All databank applications are fully interactive, allowing the user to add, edit and complete component data. This CD-ROM is a must-have for all electronics enthusiasts.

ISBN 978-90-5381-159-7 • £24.90 • US \$39.50



OBD Analyser NG

(September 2009)

The compact OBD2 Analyser in the June 2007 issue was an enormous success – not surprising for an affordable handheld onboard diagnostics device with automatic protocol recognition and error codes explained in plain language. Now enhanced with a graphical display, Cortex M3 processor and an Open Source user interface, the next generation of Elektor's standalone analyser sets new standards for a DIY OBD2 project. The key advantage of this OBD2 Analyser NG is that it's self-contained and can plug into any OBD diagnostic port.

Kit of parts including DXM Module, PCB SMD-prefitted, case, mounting materials and cable

Art.# 090451-71 • £84.00 • US \$135.00



Bestseller!

Experimenting with the MSP430

(May 2009)

All the big electronics manufacturers supply microcontrollers offering a wide range of functions. Texas Instruments supplies handy USB evaluation sticks with related software for its low-cost MSP430 controllers. Unfortunately the I/O facilities are somewhat limited. These can be substantially enhanced with the help of the Elektor MSP430 board.

PCB, populated and tested

Art.# 080558-91 • £35.00 • US \$55.00

TI eZ430-F2013 Evaluation Kit

Art.# 080558-91 • £24.50 • US \$35.00

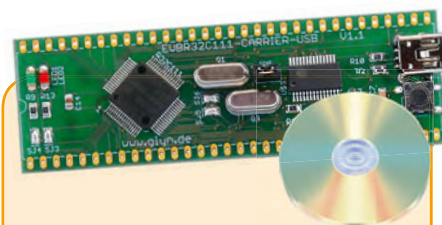

The 32-bit Machine

(April 2009)

With this attractively priced starter kit you get everything you need for your first hands-on experiments with the new R32C/111 32-bit microcontroller. The power supply is drawn from your computer via the USB connection, which simplifies things rather nicely. The starter kit consists of an R32C carrier board (a microcontroller module equipped with the R32C/111 chip) and a software CD-ROM containing the necessary development tools. As with the earlier R8C/13 'Tom Thumb' project in Elektor Electronics (November 2005 through March 2006), the R32C carrier board is an in-house-development of Glyn, an authorised distributor for Renesas in Germany.

R32C/111 Starterkit (32-bit-Controller-board & CD-ROM)

Art.# 080928-91 • £27.00 • US \$42.50

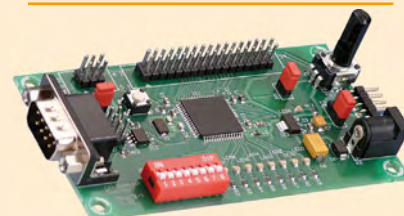

Automotive CAN controller

(April 2009)

Since cars contain an ever increasing amount of electronics, students learning about motor vehicle technology also need to know more about electronics and microcontrollers. In collaboration with the Timloto o.s. Foundation in the Netherlands, Elektor designed a special controller PCB, which will be used in schools in several countries for teaching students about automotive technologies. But it can also be used for other applications, of course. The heart of this board is an Atmel AT90CAN32 with a fast RISC core.

Kit of parts, incl. PCB with SMDs prefitted

Art.# 080671-91 • £52.00 • US \$79.00

October 2009 (No. 394) £ US\$

+ + + Product Shortlist October: See www.elektor.com + + +

September 2009 (No. 393)

R32C Application Board

080082-71 Kit of parts including Application Board with SMD parts prefitted, plus all other components see www.elektor.com
 080928-91 R32C Starterkit: Processor board populated and tested, Toolchain on CD 27.00..... 42.50

OBD Analyser NG

090451-71 Kit of parts including DXM Module, PCB SMD-prefitted, case, mounting materials and cable 84.00..... 135.00

Battery Monitor

030451-72 LC display 11.00..... 15.00
 080824-1 Printed circuit board 12.90..... 18.75
 080824-41 Programmed controller LPC2103 16.50..... 24.00

July/August 2009 (No. 391/392)

Luxeon Logic

081159-41 Programmed controller ATtiny25 6.40..... 10.50

Programmable Nokia RTTL Player

090243-41 Programmed ATtiny13 6.40..... 10.50

Breadboard/Perfboard Combo

080937-1 Printed circuit board 25.50..... 42.00

Annoy-a-Tron

090084-41 Programmed controller ATtiny13 6.40..... 10.50

Fan Speed Controller

070579-41 Programmed controller ATtiny13 7.70..... 12.60

Floating Message

080441-41 Programmed controller PIC16F616 6.40..... 10.50

Pulse Clock Driver with DCF Synchronisation

090035-41 Programmed PIC16F648A 7.70..... 12.60

Frequency and Time Reference with ATtiny2313

080754-41 Programmed ATtiny2313, 20 MHz configuration 7.70..... 12.60

PIC Detects Rotation Direction

081164-41 Programmed PIC12F509A 6.40..... 10.50

Simple Temperature Measurement and Control

090204-41 Programmed controller ATmega48 7.70..... 12.60

Two-button Digital Lock

090127-41 Programmed ATtiny2313 7.70..... 12.60

Full-colour Night-flight Illumination

080060-41 Programmed controller PIC12F675 6.40..... 10.50

Chill Out Loud

080700-41 Programmed controller PIC12F629 6.40..... 10.50

USB Radio Terminal

071125-71 868 MHz assembled and tested module 7.30..... 11.90
 080068-91 Assembled and tested R8C Board with USB 55.00..... 82.50

Digital Sweep and Sinewave Generator

080577-41 Programmed ATmega48-20PV 6.40..... 10.50

June 2009 (No. 390)

Campsite AC Monitor

060316-1 Printed circuit board 21.50..... 30.00

ATM18 = RFID Savvy

080910-91 PCB, partly populated PCB populated with all SMDs 16.50..... 26.00

May 2009 (No. 389)

Experimenting with the MSP430

080558-91 PCB, populated and tested 35.00..... 55.00
 080558-92 TI eZ430-F2013 Evaluation Kit 24.50..... 35.00

RGB LED Driver

080178-41 Programmed controller 8.90..... 13.75

April 2009 (No. 388)

The 32-bit Machine

080928-91 R32C/111 Starterkit (32-bit-Controllerboard & CD-ROM) 27.00..... 42.50

Bestsellers

Books	1	➔	310 Circuits ISBN 978-0-905705-78-1 £29.90..... US \$45.00
	2	➔	C# 2008 and .NET programming ISBN 978-0-905705-81-1 £29.50..... US \$44.50
	3	⬆	Elektor Personal Organizer 2010 ISBN 978-90-5381-247-1 £24.90..... US \$41.90
	4	⬇	C Programming for Embedded Microcontrollers ISBN 978-0-905705-80-4 £32.50..... US \$52.00
	5	⬇	Artificial Intelligence ISBN 978-0-905705-77-4 £32.00..... US \$46.00
CD/DVD-ROMs	1	➔	DVD LED Toolbox ISBN 978-90-5381-245-7 £28.50..... US \$54.00
	2	➔	ECD 5 ISBN 978-90-5381-159-7 £24.90..... US \$39.50
	3	➔	DVD Elektor 1990 through 1999 ISBN 978-0-905705-76-7 £69.00..... US \$99.00
	4	⬇	DVD Elektor 2008 ISBN 978-90-5381-235-8 £17.50..... US \$35.00
	5	⬇	DVD i-TRIXX Freeware Collection ISBN 978-90-5381-244-0 £27.50..... US \$39.50
Kits & Modules	1	➔	MSP430: PCB, populated and tested Art. # 080558-91 £35.00..... US \$55.00
	2	➔	USB Radio Terminal Art. # 071125-71 £7.20..... US \$11.50
	3	⬇	MSP430: TI eZ430-F2013 Evaluation Kit Art. # 080558-92 £24.50..... US \$35.00
	4	⬆	ElektorWheeler Art. # 090248-71 £1380.00..... US \$2275.00
	5	⬇	The 32-bit Machine Art. # 080928-91 £27.00..... US \$42.50

Order quickly and securely through www.elektor.com/shop or use the Order Form near the end of the magazine!

elektor SHOP

Elektor
 Regus Brentford
 1000 Great West Road
 Brentford TW8 9HH • United Kingdom
 Tel. +44 20 8261 4509
 Fax +44 20 8261 4447
 Email: sales@elektor.com

Blue LEDs fight winter blues

During the wintertime many people suffer from tiredness and a general lack of energy. The effect is caused by lack of sunlight, among others. Recent studies indicate that these negative effects can be largely prevented by a controlled, daily dose of blue light. Our winter blues fighter circuit contains no fewer than 84 LEDs capable of emitting a considerable amount of blue light. Half an hour's exposure on a daily basis should be sufficient to make you feel better and fitter. The circuit contains a PWM system for the brightness control, as well as a programmable timer with a range of 4 to 30 minutes, not forgetting a display showing the remaining 'on' time.

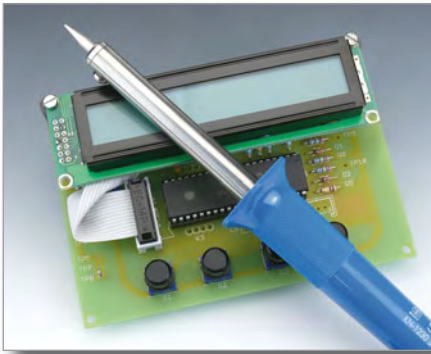
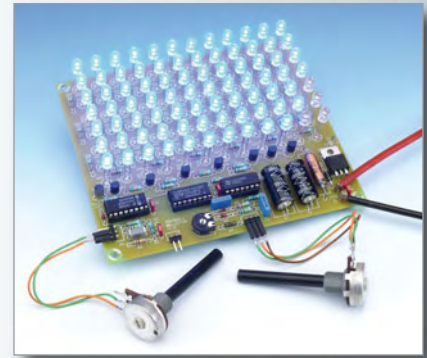

Soldering station with measurement function

This project shows that it's still economical to retro-fit a simple temperature control to a common 30-watt solder iron. The core of the circuit is a PIC18F4520 microcontroller employing pulsewidth modulation to regulate the energy supply to the solder iron. Settings are shown on a two-line LC display. An additional feature of the circuit is its two measurement inputs allowing two direct voltages to be measured (0–10 V and 0–40 V) and of course displayed. These channels employ the PIC's internal A/D converters.

R32C webservice

As promised in the September 2009 issue we'll present a small module for the R32C experimenter's board that's sure to extend the CPU's communicative skills considerably. We're talking about an Ethernet network module comprising a hard-wired TCP/IP chip with a 10/100 Mbit/s interface, a network connector with a transformer and status LEDs. The project enables a webservice or another Internet application to be implemented without bothering about details like the TCP/IP protocol.



Article titles and magazine contents subject to change, please check 'Magazine' on www.elektor.com

The November 2009 issue comes on sale on Thursday, October 22, 2009 (UK distribution only). UK mainland subscribers will receive the issue between October 17 and 20, 2009.

www.elektor.com www.elektor.com www.elektor.com www.elektor.com www.elektor.com

Elektor on the web

All magazine articles back to volume 2000 are available online in pdf format. The article summary and parts list (if applicable) can be instantly viewed to help you positively identify an article. Article related items are also shown, including software downloads, circuit boards, programmed ICs and corrections and updates if applicable. Complete magazine issues may also be downloaded.

In the Elektor Shop you'll find all other products sold by the publishers, like CD-ROMs, kits and books. A powerful search function allows you to search for items and references across the entire website.

Also on the Elektor website:



- Electronics news and Elektor announcements
- Readers Forum
- PCB, software and e-magazine downloads
- Surveys and polls
- FAQ, Author Guidelines and Contact



Description	Price each	Qty.	Total	Order Code
Practical Eco-Electrical Home Power System	NEW £24.90			
Your own Eco-Electrical Home Power System	NEW £16.50			
Elektor Personal Organizer 2010	NEW £24.90			
310 Circuits	NEW £29.90			
C# 2008 and .NET programming for Electronic Engineers	£29.50			
DVD LED Toolbox	£28.50			
Free Elektor Catalogue 2009				
Sub-total				
P&P				
Total paid				

Prices and item descriptions subject to change. The publishers reserve the right to change prices without prior notification. Prices and item descriptions shown here supersede those in previous issues. E. & O.E.

METHOD OF PAYMENT
(see reverse before ticking as appropriate)

- Bank transfer
- Cheque
(UK-resident customers ONLY)
- Giro transfer
-  

Expiry date: _____

Verification code: _____

Please send this order form to*
(see reverse for conditions)

Elektor
Regus Brentford
1000 Great West Road
Brentford TW8 9HH
United Kingdom

Tel.: +44 20 8261 4509
Fax: +44 20 8261 4447
www.elektor.com
sales@elektor.com

*USA and Canada residents should use \$ prices, and send the order form to:
Elektor US
PO Box 876
Peterborough NH 03458-0876
Phone: 603-924-9464
Fax: 603-924-9467
E-mail: custservus@elektor.com

Name _____

Address + Post code _____

Tel. _____ Email _____

Date - - Signature _____

EL10

Yes, I am taking out an annual subscription to Elektor and receive a free 2GB MP3 player*.



- I would like:
- Standard Subscription (11 issues)
 - Subscription-Plus (11 issues plus the Elektor Volume 2009 CD-ROM + exclusive access to www.elektor-plus.com) **TIP**

* Offer available to Subscribers who have not held a subscription to Elektor during the last 12 months. Offer subject to availability. See reverse for rates and conditions.

Name _____



Address + Post code _____

Tel. _____ Email _____

Date - - Signature _____

EL10

METHOD OF PAYMENT
(see reverse before ticking as appropriate)

- Bank transfer
- Cheque
(UK-resident customers ONLY)
- Giro transfer
-  

Expiry date: _____

Verification code: _____

Please send this order form to

Elektor
Regus Brentford
1000 Great West Road
Brentford TW8 9HH
United Kingdom

Tel.: +44 20 8261 4509
Fax: +44 20 8261 4447
www.elektor.com
subscriptions@elektor.com

ORDERING INSTRUCTIONS, P&P CHARGES

All orders, except for subscriptions (for which see below), must be sent BY POST or FAX to our Brentford address using the Order Form overleaf. Online ordering: www.elektor.com/shop

Readers in the USA and Canada should send orders, except for subscriptions (for which see below), to the USA address given on the order form. Please apply to Elektor US for applicable P&P charges. Please allow 4-6 weeks for delivery.

Orders placed on our Brentford office must include P&P charges (Priority or Standard) as follows: Europe: £6.00 (Standard) or £7.00 (Priority) Outside Europe: £9.00 (Standard) or £11.00 (Priority)

HOW TO PAY

All orders must be accompanied by the full payment, including postage and packing charges as stated above or advised by Customer Services staff.

Bank transfer into account no. 40209520 held by Elektor Electronics with ABN-AMRO Bank, London. IBAN: GB35 ABNA 4050 3040 2095 20. BIC: ABNAGB2L. Currency: sterling (UKP). Please ensure your full name and address gets communicated to us.

Cheque sent by post, made payable to Elektor Electronics. We can only accept sterling cheques and bank drafts from UK-resident customers or subscribers. We regret that no cheques can be accepted from customers or subscribers in any other country.

Giro transfer into account no. 34-152-3801, held by Elektor Electronics. Please do not send giro transfer/deposit forms directly to us, but instead use the National Giro postage paid envelope and send it to your National Giro Centre.

Credit card VISA and MasterCard can be processed by mail, email, web, fax and telephone. Online ordering through our website is SSL-protected for your security.

COMPONENTS

Components for projects appearing in Elektor are usually available from certain advertisers in this magazine. If difficulties in the supply of components are envisaged, a source will normally be advised in the article. Note, however, that the source(s) given is (are) not exclusive.

TERMS OF BUSINESS

Delivery Although every effort will be made to dispatch your order within 2-3 weeks from receipt of your instructions, we can not guarantee this time scale for all orders. **Returns** Faulty goods or goods sent in error may be returned for replacement or refund, but not before obtaining our consent. All goods returned should be packed securely in a padded bag or box, enclosing a covering letter stating the dispatch note number. If the goods are returned because of a mistake on our part, we will refund the return postage. **Damaged goods** Claims for damaged goods must be received at our Brentford office within 10-days (UK); 14-days (Europe) or 21-days (all other countries). **Cancelled orders** All cancelled orders will be subject to a 10% handling charge with a minimum charge of £5.00. **Patents** Patent protection may exist in respect of circuits, devices, components, and so on, described in our books and magazines. Elektor does not accept responsibility or liability for failing to identify such patent or other protection. **Copyright** All drawings, photographs, articles, printed circuit boards, programmed integrated circuits, diskettes and software carriers published in our books and magazines (other than in third-party advertisements) are copyright and may not be reproduced or transmitted in any form or by any means, including photocopying and recording, in whole or in part, without the prior permission of Elektor in writing. Such written permission must also be obtained before any part of these publications is stored in a retrieval system of any nature. Notwithstanding the above, printed-circuit boards may be produced for private and personal use without prior permission. **Limitation of liability** Elektor shall not be liable in contract, tort, or otherwise, for any loss or damage suffered by the purchaser whatsoever or howsoever arising out of, or in connexion with, the supply of goods or services by Elektor other than to supply goods as described or, at the option of Elektor, to refund the purchaser any money paid in respect of the goods. **Law** Any question relating to the supply of goods and services by Elektor shall be determined in all respects by the laws of England.

January 2009

SUBSCRIPTION RATES FOR ANNUAL SUBSCRIPTION

	Standard	Plus
United Kingdom	£49.00	£61.50
Surface Mail		
Rest of the World	£63.00	£75.50
Airmail		
Rest of the World	£79.00	£91.50
USA	£64.95	See www.elektor-usa.com for special offers
Canada	£75.95	

HOW TO PAY

Bank transfer into account no. 40209520 held by Elektor Electronics with ABN-AMRO Bank, London. IBAN: GB35 ABNA 4050 3040 2095 20. BIC: ABNAGB2L. Currency: sterling (UKP). Please ensure your full name and address gets communicated to us.

Cheque sent by post, made payable to Elektor Electronics. We can only accept sterling cheques and bank drafts from UK-resident customers or subscribers. We regret that no cheques can be accepted from customers or subscribers in any other country.

Giro transfer into account no. 34-152-3801, held by Elektor Electronics. Please do not send giro transfer/deposit forms directly to us, but instead use the National Giro postage paid envelope and send it to your National Giro Centre.

Credit card VISA and MasterCard can be processed by mail, email, web, fax and telephone. Online ordering through our website is SSL-protected for your security.

SUBSCRIPTION CONDITIONS

The standard subscription order period is twelve months. If a permanent change of address during the subscription period means that copies have to be despatched by a more expensive service, no extra charge will be made. Conversely, no refund will be made, nor expiry date extended, if a change of address allows the use of a cheaper service.

Student applications, which qualify for a 20% (twenty per cent) reduction in current rates, must be supported by evidence of studentship signed by the head of the college, school or university faculty.

A standard Student Subscription costs £39.20, a Student Subscription-Plus costs £51.70 (UK only).

Please note that new subscriptions take about four weeks from receipt of order to become effective.

Cancelled subscriptions will be subject to a charge of 25% (twenty-five per cent) of the full subscription price or £7.50, whichever is the higher, plus the cost of any issues already dispatched. Subscriptions cannot be cancelled after they have run for six months or more.

January 2009

Visit China with Elektor

 combine electronics and culture

events

Elektor's next Study Trip to China is planned for 7-16 November 2009. And you can join us! Check your diary today and visit the Elektor website for more detailed information.

Programme:

- A visit to the China Electronics Fair in Shanghai
- Shopping in electronics department stores
- Company visits
- Conference about doing business in China
- Culture: The Great Wall, The Temple of Heaven, The Forbidden City, Tiananmen square and The Shanghai TV tower
- A cycling tour through Beijing

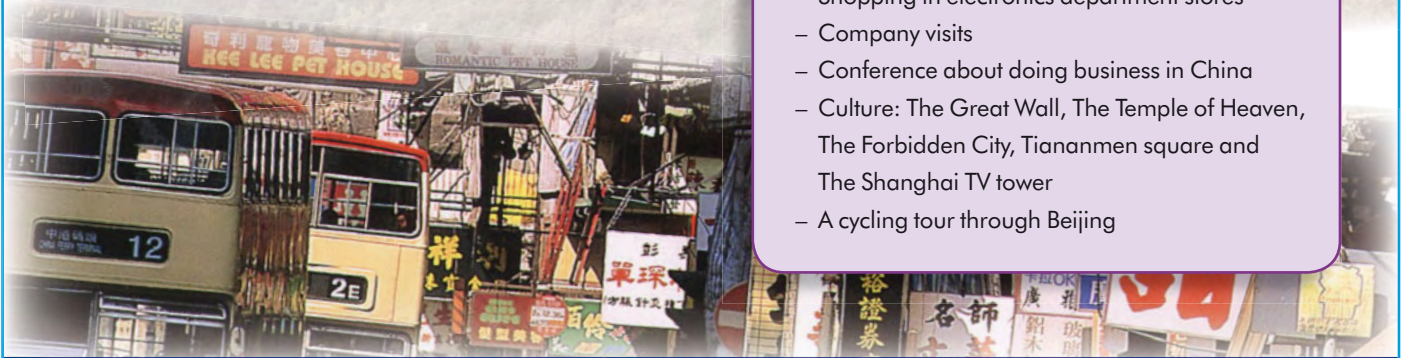

Further information at www.elektor.com/china

INDEX OF ADVERTISERS

Antex Electronics Ltd	www.antex.co.uk	13	Microchip	www.microchip.com/8bit	25
APD, Showcase	www.apdanglia.org.uk	79	MikroElektronika	www.mikroe.com	3
Avit Research, Showcase	www.avitresearch.co.uk	78	MQP Electronics, Showcase	www.mqp.com	79
Beijing Draco Electronics Ltd	www.ezpcb.com	53	Netronics, Showcase	www.canalyser.co.uk	79
Bitscope Designs	www.bitscope.com	2	Newbury Electronics	www.newburyelectronics.co.uk	75
Black Robotics, Showcase	www.blackrobotics.com	78	Nurve Networks	www.xgamestation.com	75
ByVac, Showcase	www.byvac.com	78	Parallax	www.parallax.com	31
Decibit Co. Ltd, Showcase	www.decibit.com	78	PCBCORE	www.pcbcore.com	53
Designer Systems, Showcase	www.designersystems.co.uk	78	Peak Electronic Design	www.peakelec.co.uk	42
EasyDAQ, Showcase	www.easydaq.biz	78	Pico	www.picotech.com/scope1036	19
Easysync, Showcase	www.easysync.co.uk	78	Quasar Electronics	www.quasarelectronics.com	47
Elnec, Showcase	www.elnec.com	78	Robot Electronics, Showcase	www.robot-electronics.co.uk	79
Eurocircuits	www.eurocircuits.com	75	Robotiq, Showcase	www.robotiq.co.uk	79
First Technology Transfer Ltd, Showcase	www.ftt.co.uk	78	Showcase	78, 79	
FlexiPanel Ltd, Showcase	www.flexipanel.com	78	Schaeffer AG	www.schaeffer-ag.de	53
Future Technology Devices, Showcase	www.ftdichip.com	78	USB Instruments, Showcase	www.usb-instruments.com	79
Good Will Instruments	www.gwinstek.com	65	Virtins Technology, Showcase	www.virtins.com	79
Hameg, Showcase	www.hameg.com	78			
HexWax Ltd, Showcase	www.hexwax.com	78			
Labcenter	www.labcenter.com	88			
Lcdmod Kit, Showcase	www.lcdmodkit.com	78			
London Electronics College, Showcase	www.lec.org.uk	78			

Advertising space for the issue 19 November 2009 may be reserved not later than 20 October 2009
with Huson International Media - Cambridge House - Gogmore Lane - Chertsey, Surrey KT16 9AP - England - Telephone 01932 564 999 - Fax 01932 564 998 - e-mail: ros.elgar@husonmedia.com to whom all correspondence, copy instructions and artwork should be addressed.



GO FASTER WITH PROTEUS PCB DESIGN

The latest version of the Proteus Design Suite harnesses the power of your computer's graphics card to provide lightning fast performance. Together with unique transparency options it's now easier than ever to navigate and understand large, multi-layer boards.

PROTEUS DESIGN SUITE Features:

- Hardware Accelerated Performance.
- Unique Thru-View™ Board Transparency.
- Over 35k Schematic & PCB library parts.
- Integrated Shape Based Auto-router.
- Flexible Design Rule Management.
- Polygonal and Split Power Plane Support.
- Board Autoplacement & Gateswap Optimiser.
- Direct CAD/CAM, ODB++ & PDF Output.
- Integrated 3D Viewer with 3DS and DXF export.
- Mixed Mode SPICE Simulation Engine.
- Co-Simulation of PIC, AVR, 8051 and ARM7.
- Direct Technical Support at no additional cost.

All levels of the **Proteus Design Suite** include a world class, fully integrated shape-based autorouter at no additional cost - prices start from just £150 exc. VAT & delivery

labcenter  www.labcenter.com
Electronics

Labcenter Electronics Ltd. 53-55 Main Street, Grassington, North Yorks. BD23 5AA.
Registered in England 4692454 Tel: +44 (0)1756 753440, Email: info@labcenter.com

Visit our website or
phone 01756 753440
for more details