

PASSIVE VU METER

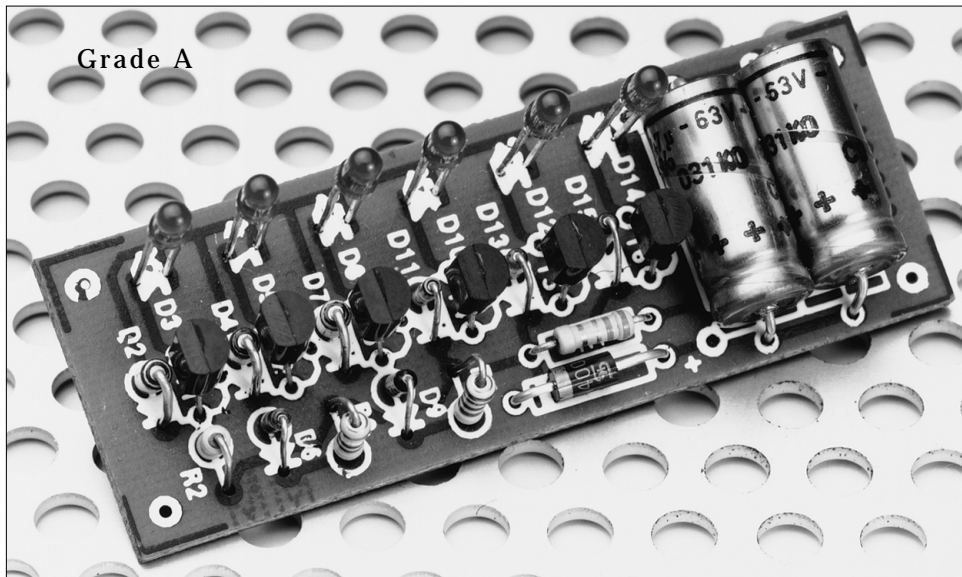

Design by T. Giesberts

If you want to fit your loudspeaker enclosure(s) with a drive indicator, it is best to use a unit that does not need a power supply. The September 1995 issue of this magazine (p. 75) described an AF POWER INDICATOR for PA (public address) loudspeakers, that is, for fairly high power outputs. This article describes a passive VU unit for smaller amplifiers and loudnesses—see Fig. 1. It consists of a rectifier and six (may be fewer or more) identical stages that each comprises a current source, a zener diode and a light emitting diode, LED. The current sources are built from JFETs with interconnected gate-source terminals—here, Type BF256A. The saturation current, I_{DSS} , of these devices with a

drain-source voltage, $U_{DS} = 15\text{ V}$ is about 5 mA. This current is not exactly constant, but is perfectly all right for driving a low-current LED and will not exceed the permissible value of 7 mA. Networks R_2 - D_2 , R_3 - D_4 , and R_4 - D_7 are protection circuits; they prevent the drain voltage of the relevant JFET rising above 30 V, which normally destroys the transistor.

The rectifying circuit is formed by D_1 and capacitors C_1 , C_2 . Resistor R_1 limits the peak current to about 1.5 A at a source voltage, U_S , of 50 V. Since it is in series with C_1 and C_2 , and thus in parallel with the amplifier output, it has no effect on the level of the input voltage. The peak output voltage of the rectifier is applied directly to the single LED stages. The potential across C_1 and C_2 is not exactly equal to the instantaneous peak voltage, but, because of time

constant R_1 - C_1 - C_2 , is a good average of it. Consequently, the unit indicates briefly the instantaneous peak voltage, and then the mean of it.

The cworkering of the three parts of a stage is easily understood by considering the following. If the rectified and smoothed voltage rises a few volts over the level set by the zener diode, the current source comes into action and causes the LED to light. Since the (input) voltage to the meter is directly proportional to the amplifier output and the (assumed constant) impedance of the loudspeaker, the indicated threshold level (in watts) can be converted into a zener voltage:

$$P = U_{RMS}/R = (U_S/\sqrt{2})^2/R = U_S^2/2R$$

∴

$$U_S = U_{ZENER} = \sqrt{2PR} - U_{LED}$$

where U_{LED} is the starting voltage of the LED (and the voltage drop across the current source), which is equal to 2 V. Thus, for an indication of 100 W into an 8 Ω loudspeaker, the zener voltage is

$$U_{ZENER} = \sqrt{(100 \times 2 \times 8)} - 2 = 38\text{ V.}$$

The zener to be used should have the next lower rating in the table (36 V), so that it lights brightly when the output is 100 W. In this way, the stages may be designed more or less to individual requirements.

In the most sensitive stage, T_1 - D_2 - D_3 , the zener diode is, strictly speaking, superfluous since the indicated power is determined entirely by the threshold values of D_1 , T_1 and D_3 .

The input current to the circuit has a peak level of $U_{in}/R_1 = 50/33 = 1.5\text{ A}$. With a constant 1 kHz signal and an output level of 150 W into 8 Ω, the current drops to 280 mA. However, if this signal is pulsed with a duty factor of 1:99, the current rises to 1.3 A owing to the then low average potential across capacitor C_1 . It is noteworthy

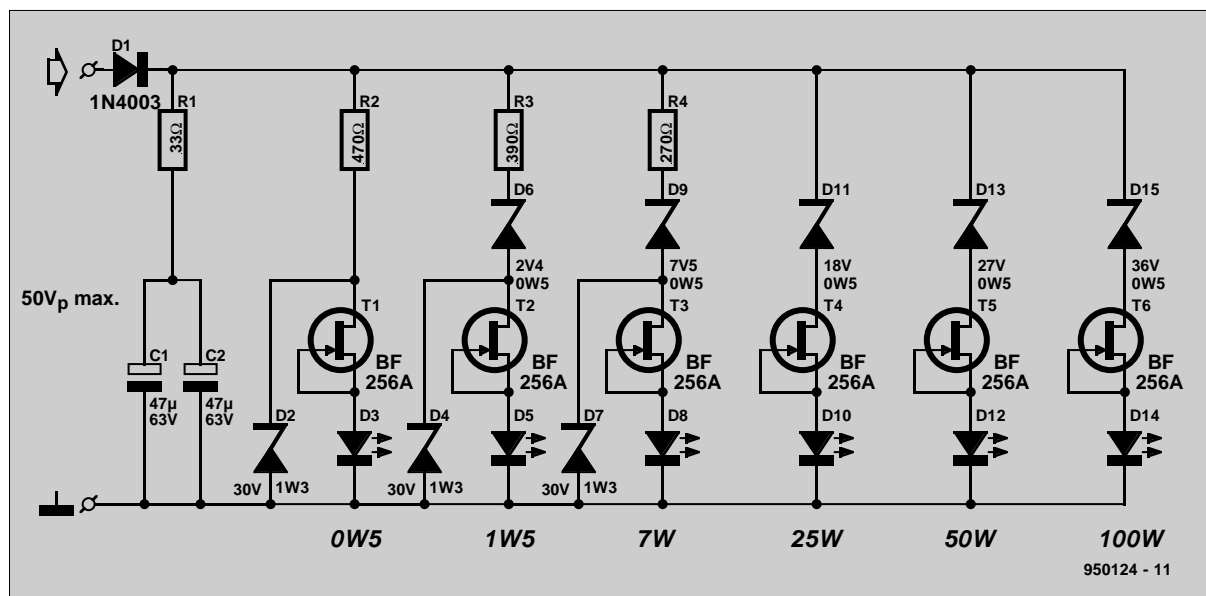

Fig. 1. The circuit of the passive VU meter is based on six identical stages.

that the circuit is not truly passive, because it draws its energy from the audio signal. This means, by the way, that there is a (very) slight rise in the distortion!

The circuit may be built quickly and without any undue difficulties on the printed-circuit board shown in Fig. 2. The finished board is best fitted in a small plastic enclosure, which is then fitted on to the loudspeaker box(es).

Parts list

Resistors:

- R₁ = 33 Ω
- R₂ = 470 Ω
- R₃ = 390 Ω
- R₄ = 270 Ω

Capacitors:

- C₁, C₂ = 47 μF, 63 V

Semiconductors:

- D₁ = 1N4003
- D₂, D₄, D₇ = zener diode 30 V, 1.3 W
- D₃, D₅, D₈, D₁₀, D₁₂, D₁₄ = low-current LED
- D₆ = zener diode 2.4 V, 500 mW
- D₉ = zener diode 7.5 V, 500 mW
- D₁₁ = zener diode 18 V, 500 mW
- D₁₃ = zener diode 27 V, 500 mW

- D₁₅ = zener diode 36 V, 500 mW
- T₁-T₆ = BF256A

Miscellaneous:
PCB Order no. 950124

[950124]

Standard zener diode voltages (V)

1.0*	10	100
	11	110
	12	120
1.4*	13	130
1.5*	15	150
	16	160
	18	180
2.0*	20	200
	22	
2.4	24	
2.7	27	
3.0	30	
3.3	33	
3.6	36	
3.9	39	
4.3	43	
4.7	47	
5.1	51	
5.6	56	
6.2	62	
6.8	68	
7.5	75	
8.2	82	
9.1	91	

* rare

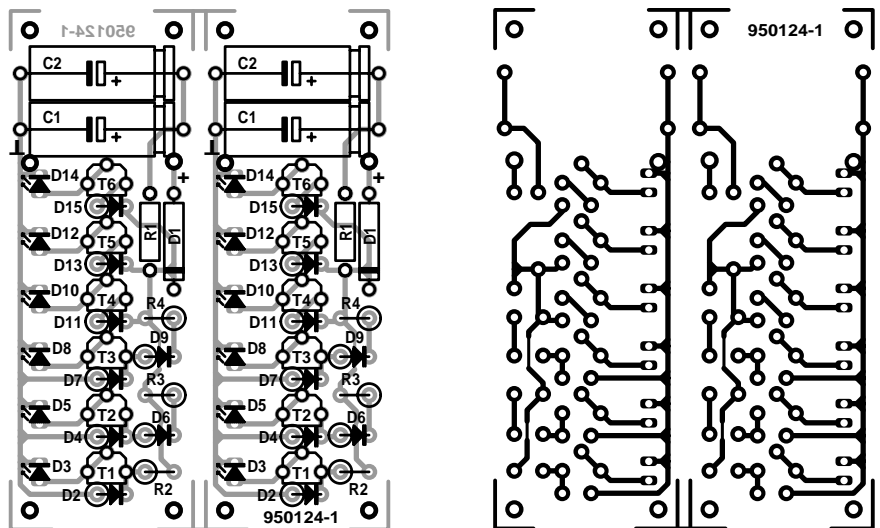

Fig. 2. The printed-circuit board for the passive VU meter must be cut into two before any assembly work is begun.