

bass extension for surround sound

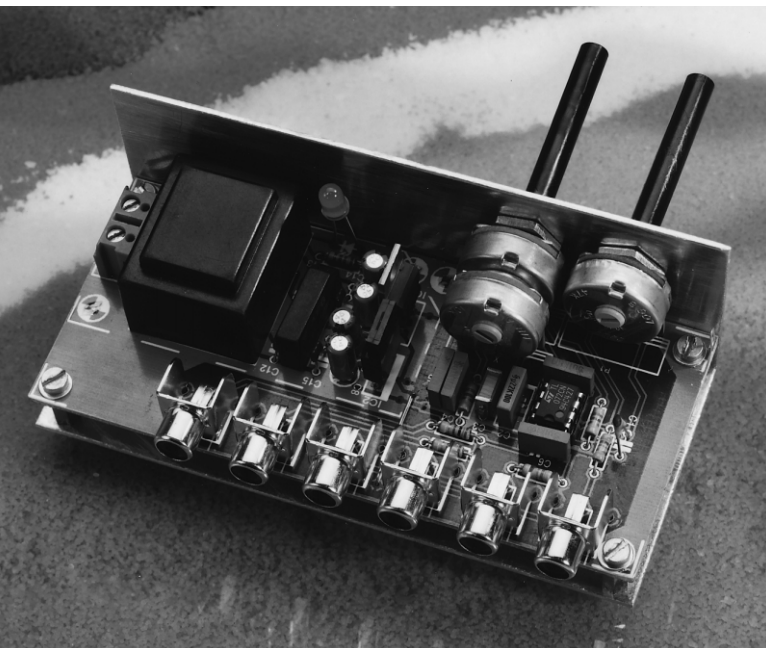

The extension is intended primarily for surround-sound installations that need some boosting of the bass frequencies but where an additional subwoofer cannot be afforded. It is based on a disused mono a.f. amplifier and loudspeaker. If these provide reasonable bass performance, they can be con-

verted into a fairly good subwoofer with the aid of an active low-pass filter—see Figure 1.

The input signals for the left-hand and right-hand channels are applied to audio sockets K₁ and K₂ respectively. They are output via audio sockets K₃ and K₄ to which the surround-sound decoder is

connected.

The signals of the two channels are summed in IC_{1a}, which also functions as input amplifier. The amplification, and therefore the sensitivity of the 'subwoofer', can be adjusted with P₁.

The output of IC_{1a} is applied to a 2nd-order Butterworth low-pass filter. The cut-off frequency of this active filter can be set between 40 Hz and 120 Hz with stereo potentiometer P₂. The response char-

acteristic of the filter at both these frequencies is shown in Figure 2. The actual cut-off point depends on individual taste.

The said mono amplifier is connected to audio output sockets K₅ and K₆.

The power supply for the circuit is simple and consists of a small mains transformer, Tr₁, a

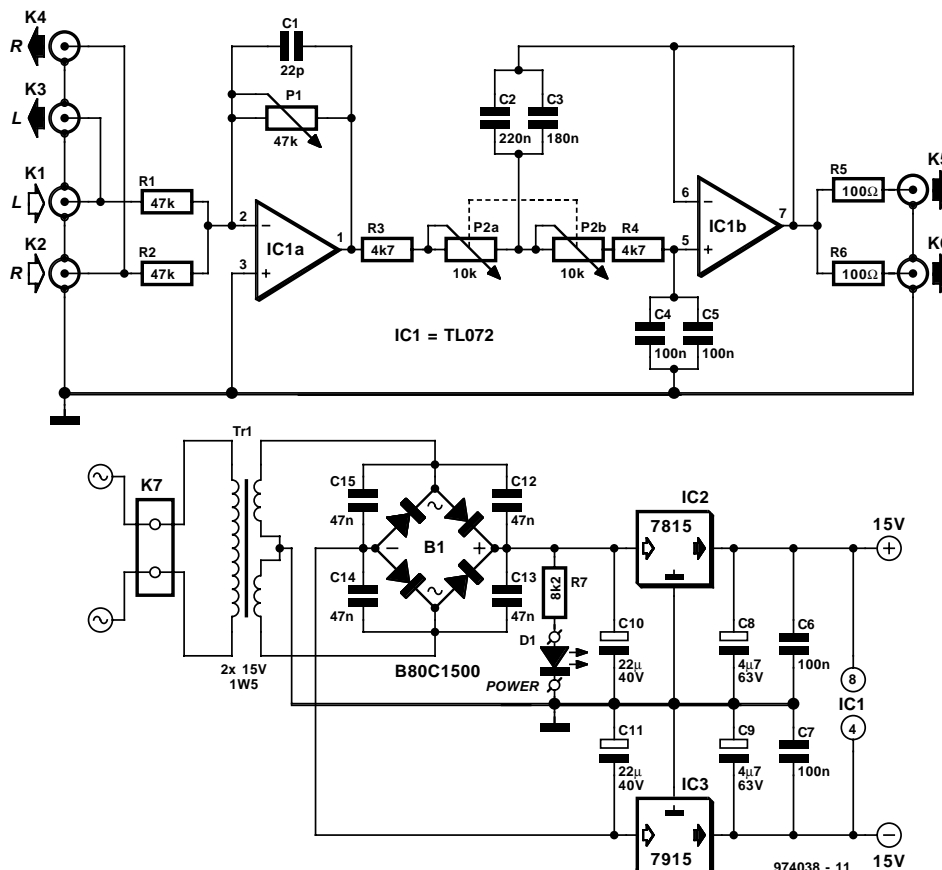
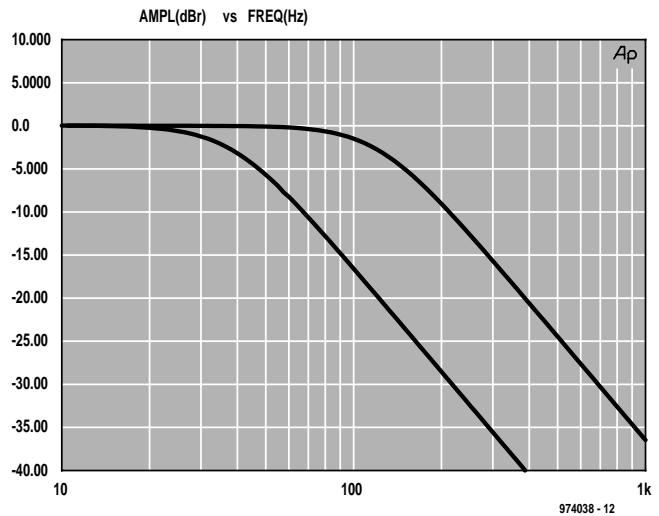

Parts list

Resistors:

- R₁, R₂ = 47 kΩ
- R₃, R₄ = 4.7 kΩ
- R₅, R₆ = 100 Ω
- R₇ = 8.2 kΩ
- P₁ = 47 kΩ logarithmic potentiometer
- P₂ = 10 kΩ, linear stereo potentiometer

Capacitors:

- C₁ = 22 pF
- C₂ = 220 nF
- C₃ = 180 nF
- C₄–C₇ = 100 nF
- C₈, C₉ = 4.7 μF, 63 V, radial
- C₁₀, C₁₁ = 22 μF, 40 V, radial
- C₁₂–C₁₅ = 47 nF ceramic

Semiconductors:

- D₁ = LED, high efficiency

Integrated circuits:

- IC₁ = TL072CP
- IC₂ = 7815
- IC₃ = 7915

Miscellaneous:

- K₁–K₆, K₈–K₉ = audio socket for board mounting
- K₇ = 2-way terminal block, pitch 7.5 mm
- B₁ = B80C1500
- Tr₁ = mains transformer, 2 × 15 V secondaries, 1.5 VA

bridge rectifier, B_1 , antihunt capacitors $C_{12}-C_{15}$, a number of smoothing and decoupling capacitors, and two integrated voltage regulators, IC_2 and IC_3 .

The filter circuit is best built on the printed-circuit board shown in Figure 3, which is, however, not available ready made.

The filter should be housed in a metal case. Moreover, P_1 and P_2 should preferably be types with a metal enclosure. Hum is prevented by earthing the case and the enclosures.

The harmonic distortion, with two input signals of 200 mV and a bandwidth of 22 kHz, is 0.0016% at 30 Hz.

Although not of prime importance at low frequencies, the polarity of the 'subwoofer' should be the reverse of that of the remainder of the system since the present circuit inverts the signals.

[974038]

ELEKTOR		
240V ~	50Hz	
No. 974038		
P = 1VA5		

